



Intel[®] 80331 I/O Processor

Design Guide

March 2005



INFORMATION IN THIS DOCUMENT IS PROVIDED IN CONNECTION WITH INTEL® PRODUCTS. NO LICENSE, EXPRESS OR IMPLIED, BY ESTOPPEL OR OTHERWISE, TO ANY INTELLECTUAL PROPERTY RIGHTS IS GRANTED BY THIS DOCUMENT. EXCEPT AS PROVIDED IN INTEL'S TERMS AND CONDITIONS OF SALE FOR SUCH PRODUCTS, INTEL ASSUMES NO LIABILITY WHATSOEVER, AND INTEL DISCLAIMS ANY EXPRESS OR IMPLIED WARRANTY, RELATING TO SALE AND/OR USE OF INTEL PRODUCTS INCLUDING LIABILITY OR WARRANTIES RELATING TO FITNESS FOR A PARTICULAR PURPOSE, MERCHANTABILITY, OR INFRINGEMENT OF ANY PATENT, COPYRIGHT OR OTHER INTELLECTUAL PROPERTY RIGHT.

Intel products are not intended for use in medical, life saving, life sustaining applications.

Intel may make changes to specifications and product descriptions at any time, without notice.

Contact your local Intel sales office or your distributor to obtain the latest specifications and before placing your product order.

Copies of documents which have an order number and are referenced in this document, or other Intel literature, may be obtained by calling 1-800-548-4725, or by visiting Intel's website at <http://www.intel.com>.

AlertVIEW, AnyPoint, AppChoice, BoardWatch, BunnyPeople, CablePort, Celeron, Chips, CT Connect, CT Media, Dialogic, DM3, EtherExpress, ETOX, FlashFile, i386, i486, i960, iCOMP, InstantIP, Intel, Intel logo, Intel386, Intel486, Intel740, IntelDX2, IntelDX4, IntelSX2, Intel Create & Share, Intel GigaBlade, Intel InBusiness, Intel Inside, Intel Inside logo, Intel NetBurst, Intel NetMerge, Intel NetStructure, Intel Play, Intel Play logo, Intel SingleDriver, Intel SpeedStep, Intel StrataFlash, Intel TeamStation, Intel Xeon, Intel XScale, IPLink, Itanium, LANDesk, LanRover, MCS, MMX, MMX logo, Optimizer logo, OverDrive, Paragon, PC Dads, PC Parents, PDCharm, Pentium, Pentium II Xeon, Pentium III Xeon, Performance at Your Command, RemoteExpress, Shiva, SmartDie, Solutions960, Sound Mark, StorageExpress, The Computer Inside., The Journey Inside, TokenExpress, Trillium, VoiceBrick, Vtune, and Xircom are trademarks or registered trademarks of Intel Corporation or its subsidiaries in the United States and other countries.

The ARM® and ARM Powered logo marks (the ARM marks) are trademarks of ARM, Ltd., and Intel uses these marks under license from ARM, Ltd.†

†Other names and brands may be claimed as the property of others.

Copyright© Intel Corporation 2002

Contents

| | | |
|----------|---------------------------------------------------------------|----|
| 1 | Introduction | 11 |
| 1.1 | About This Document | 11 |
| 1.1.1 | Terminology and Definitions | 12 |
| 1.1.2 | Other Relevant Documents | 14 |
| 1.2 | About the Intel® 80331 I/O Processor..... | 15 |
| 2 | Package Information | 17 |
| 2.1 | Power Plane Layout..... | 21 |
| 2.2 | Intel® 80331 I/O Processor Applications..... | 22 |
| 3 | Terminations | 23 |
| 3.1 | Analog Filters | 27 |
| 3.1.1 | V _{CCPLL} Pin Requirements..... | 27 |
| 3.2 | DDR Resistor Compensation..... | 28 |
| 3.3 | DDR Driver Compensation | 29 |
| 4 | Routing Guidelines | 31 |
| 4.1 | General Routing Guidelines..... | 31 |
| 4.2 | Crosstalk..... | 32 |
| 4.3 | EMI Considerations | 34 |
| 4.4 | Power Distribution and Decoupling..... | 34 |
| 4.4.1 | Decoupling..... | 34 |
| 4.5 | Trace Impedance..... | 36 |
| 5 | Board Layout Guidelines | 37 |
| 5.1 | Motherboard Stack Up Information..... | 37 |
| 5.2 | Adapter Card Stackup | 39 |
| 6 | PCI-X Layout Guidelines | 41 |
| 6.1 | Interrupt Routing and IDSEL Lines | 41 |
| 6.1.1 | PCI Arbitration | 42 |
| 6.1.2 | PCI Resistor Compensation | 42 |
| 6.2 | PCI General Layout Guidelines | 43 |
| 6.3 | PCI-X Topology Layout Guidelines..... | 43 |
| 6.4 | Intel® 80331 I/O Processor PCI/X Layout Analysis | 44 |
| 6.4.1 | PCI Clock Layout Guidelines | 45 |
| 6.4.2 | Single-Slot at 133 MHz | 48 |
| 6.4.3 | Embedded PCI-X 133 MHz | 49 |
| 6.4.4 | Embedded PCI-X 133 MHz Alternate Topology | 50 |
| 6.4.5 | Combination of PCI-X 133 MHz Slot and Embedded Topology | 51 |
| 6.4.6 | Combination PCI-X 133 MHz Slot and Embedded Topology 2 | 52 |
| 6.4.7 | PCI-X 100 MHz Slot Topology | 53 |
| 6.4.8 | PCI-X 100 MHz Embedded Topology..... | 54 |
| 6.4.9 | PCI-X 100 MHz Slot and Embedded Topology..... | 55 |
| 6.4.10 | PCI-X 100 MHz Slot and Embedded Topology 2..... | 56 |
| 6.4.11 | PCI-X 66 MHz Slot Topology | 57 |
| 6.4.12 | PCI-X 66 MHz Embedded Topology..... | 58 |
| 6.4.13 | PCI-X 66 MHz Mixed Mode Topology..... | 59 |

| | | |
|----------|----------------------------------------------------------------------|------------|
| 6.4.14 | PCI 66 MHz Slot Topology | 60 |
| 6.4.15 | PCI 66 MHz Embedded Topology | 61 |
| 6.4.16 | PCI 66 MHz Mixed Mode Topology | 62 |
| 6.4.17 | PCI 33 MHz Slot Topology | 63 |
| 6.4.18 | PCI 33 MHz Embedded Mode Topology | 64 |
| 6.4.19 | PCI 33 MHz Mixed Topology | 65 |
| 7 | Memory Controller | 67 |
| 7.1 | DDR Bias Voltages | 67 |
| 7.2 | Intel® 80331 I/O Processor DDR Overview | 68 |
| 7.3 | DDR 333 Signal Integrity Simulation Conditions | 69 |
| 7.3.1 | DDR 333 Stackup Example | 70 |
| 7.4 | DDR Layout Guidelines | 72 |
| 7.4.1 | Source Synchronous Signal Group | 72 |
| 7.4.1.1 | Routing Requirements | 73 |
| 7.4.2 | Clock Signal Groups | 81 |
| 7.4.2.1 | Control Signals Termination | 85 |
| 7.4.3 | Embedded Configuration | 89 |
| 7.4.3.1 | DDR 333 Source Synchronous Routine Guidelines | 89 |
| 7.4.3.2 | DDR 333 Embedded Clock Routing Recommendations | 92 |
| 7.4.3.3 | DDR 333 Embedded Address/Command/Control Routing Guidelines | 96 |
| 7.5 | DDR II 400 Layout Guidelines | 101 |
| 7.5.1 | Simulation Conditions | 102 |
| 7.5.2 | DDR II-400 Trace Width/Impedance Requirements | 103 |
| 7.5.3 | DIMM Layout Design | 104 |
| 7.5.3.1 | DDR II 400 DIMM Source Synchronous Routing | 104 |
| 7.5.3.2 | DDR II 400 Clock Routing Guidelines | 107 |
| 7.5.3.3 | DDR II 400 Address/Command/Control Routing Guidelines | 108 |
| 7.5.4 | Embedded Configuration | 110 |
| 7.5.4.1 | DDR II 400 Embedded Source Synchronous Routine Guidelines | 110 |
| 7.5.4.2 | DDR II 400 Embedded Clock Routing Recommendations | 113 |
| 7.5.4.3 | DDR II 400 Embedded Address/Command/Control Routing Guidelines | 116 |
| 7.6 | DDR Signal Termination | 120 |
| 7.7 | DDR Termination Voltage | 121 |
| 7.8 | DDR V_{REF} Voltage | 121 |
| 8 | Peripheral Local Bus | 123 |
| 8.1 | Peripheral Bus Signals | 123 |
| 8.1.1 | Address/Data Signal Definitions | 123 |
| 8.1.2 | Control/Status Signal Definitions | 123 |
| 8.1.3 | Bus Width | 124 |
| 8.1.4 | Flash Memory Support | 125 |
| 8.1.5 | Layout Guidelines for the Peripheral Bus | 126 |
| 8.2 | Topology Layout Guidelines | 127 |
| 9 | Power Delivery | 131 |
| 9.1 | Power Sequencing | 131 |
| 9.2 | Power Failure | 132 |
| 9.2.1 | Theory of Operation | 132 |
| 9.2.2 | Power Failure Sequence | 132 |
| 9.2.3 | Power Delay | 133 |

| | | |
|-----------|---------------------------------------------------------------------|------------|
| 9.3 | Battery Backup | 134 |
| 9.3.1 | Non-Battery Backup Circuits..... | 135 |
| 10 | Intel® IQ80331 Evaluation Platform Board | 137 |
| 11 | JTAG Circuitry for Debug | 139 |
| 11.1 | Requirements | 139 |
| 11.2 | JTAG Signals / Header | 140 |
| 11.3 | System Requirements | 141 |
| 11.4 | JTAG Hardware Requirements..... | 142 |
| 11.4.1 | Macraigor Raven and WindRiver Systems visionPROBE / visionICE | 142 |
| 11.4.2 | ARM Multi-ICE | 142 |
| 12 | Debug Connectors and Logic Analyzer Connectivity | 143 |
| 12.1 | Probing PCI-X Signals | 143 |
| 13 | References | 147 |
| 13.1 | Related Documents | 147 |
| 13.2 | Electronic Information | 148 |

Figures

| | | |
|----|-------------------------------------------------------------------------|-----|
| 1 | Intel® 80331 I/O Processor Functional Block Diagram..... | 16 |
| 2 | Intel® 80331 I/O Processor 829-Ball FCBGA Package Diagram..... | 18 |
| 3 | Intel® 80331 I/O Processor Preliminary Ballout (Top View) | 19 |
| 4 | Intel® 80331 I/O Processor Preliminary Ballout (Bottom View) | 20 |
| 5 | Intel® 80331 I/O Processor Power Plane Layout..... | 21 |
| 6 | Intel® 80331 I/O Processor PCI-X Adapter Card Block Diagram | 22 |
| 7 | V _{CCPLL} Configuration..... | 27 |
| 8 | Intel® 80331 I/O Processor DDRRES Resistor Compensation Circuitry | 28 |
| 9 | DDR Driver Compensation Circuitry | 29 |
| 10 | Crosstalk Effects on Trace Distance and Height | 32 |
| 11 | PCB Ground Layout Around Connectors | 33 |
| 12 | Motherboard Stackup Recommendations | 38 |
| 13 | Adapter Card Stackup | 40 |
| 14 | Interrupt and IDSEL Mapping | 41 |
| 15 | PCI RCOMP | 42 |
| 16 | PCI Clock Distribution and Matching Requirements..... | 45 |
| 17 | Single-Slot Point-to-Point Topology..... | 48 |
| 18 | Embedded PCI-X 133 MHz Topology | 49 |
| 19 | Embedded PCI-X 133 MHz Alternate Topology | 50 |
| 20 | Embedded PCI-X 133 MHz Topology | 51 |
| 21 | Embedded PCI-X 133 MHz Topology | 52 |
| 22 | Slot PCI-X 100 MHz Slot Routing Topology | 53 |
| 23 | Embedded PCI-X 100 MHz Routing Topology | 54 |
| 24 | Combination of Slot and Embedded PCI-X 100 MHz Routing Topology..... | 55 |
| 25 | Combination of Slots and Embedded PCI-X 100 MHz Routing Topology | 56 |
| 26 | PCI-X 66 MHz Slot Routing Topology | 57 |
| 27 | PCI-X 66 MHz Embedded Routing Topology | 58 |
| 28 | PCI-X 66 MHz Mixed Mode Routing Topology | 59 |
| 29 | PCI 66 MHz Topology | 60 |
| 30 | PCI 66 MHz Embedded Topology | 61 |
| 31 | PCI 66 MHz Mixed Topology | 62 |
| 32 | PCI 33 MHz Slot Routing Topology | 63 |
| 33 | PCI 33 MHz Embedded Mode Routing Topology..... | 64 |
| 34 | PCI 33 MHz Mixed Mode Routing Topology | 65 |
| 35 | 100 ohm Differential Trace | 71 |
| 36 | Source Synchronous Length Matching..... | 73 |
| 37 | Data Group Length Matching | 73 |
| 38 | DIMM DQ/DQS Topology | 79 |
| 39 | DIMM DQ/DQS Split Termination Topology | 80 |
| 40 | DDR 333 Registered DIMM Clock Topology | 83 |
| 41 | DDR 333 Unbuffered DIMM Clock Topology..... | 84 |
| 42 | Trace Length Requirements for Source Clocked Routing | 85 |
| 43 | DDR 333 DIMM Unbuffered/Registered Address/CMD Topology Lengths | 87 |
| 44 | Embedded DDR 333 DQ/DQS Topology | 91 |
| 45 | Embedded DDR 333 Buffered Clock Topology | 92 |
| 46 | Embedded DDR 333 Unbuffered Clock Topology | 95 |
| 47 | Embedded DDR 333 Unbuffered ADDR/CMD Topology | 98 |
| 48 | Embedded DDR 333 Registered ADDR/CMD Topology | 100 |

| | | |
|----|---------------------------------------------------------------------------|-----|
| 49 | Intel® 80331 I/O Processor DDRII 400 DIMM Source Synchronous Routing..... | 104 |
| 50 | DDR II 400 DIMM DQ Topology | 106 |
| 51 | DDR II 400 DIMM DQS Topology..... | 106 |
| 52 | DDR II 400 DIMM Clock Topology..... | 107 |
| 53 | DDR II 400 DIMM Address/CMD Topology | 109 |
| 54 | DDR II 400 DIMM Address/CMD Split Termination Topology | 109 |
| 55 | DDR II 400 Embedded DQ Topology | 111 |
| 56 | DDR II 400 Embedded DQS Topology..... | 112 |
| 57 | DDR II 400 Embedded Clock Topology..... | 115 |
| 58 | DDR II 400 Embedded Address/Control Topology..... | 118 |
| 59 | DDR II 400 Embedded Address/Control Topology With Split Termination..... | 119 |
| 60 | Routing Termination Resistors (top view)..... | 120 |
| 61 | DDR V_{REF} Circuit..... | 121 |
| 62 | Data Width and Low Order Address Lines | 124 |
| 63 | Four MByte Flash Memory System | 125 |
| 64 | Peripheral Bus Unlatched Bidirectional Single Load Topology..... | 127 |
| 65 | Peripheral Bus Latched Bidirectional Single Load Topology | 128 |
| 66 | Peripheral Bus Latched Bidirectional Two Load Topology | 129 |
| 67 | Power Failure Comparator Circuit | 133 |
| 68 | SCKE Circuit..... | 134 |
| 69 | Intel® IQ80331 Evaluation Platform Board CRB Block Diagram | 137 |
| 70 | Intel® 80331 I/O Processor CRB Form Factor..... | 138 |
| 71 | JTAG Header Pin Out..... | 140 |
| 72 | JTAG Signals at Powerup..... | 141 |
| 73 | JTAG Signals at Debug Startup..... | 141 |
| 74 | Example Power-Up Circuit for nTRST | 142 |

Tables

| | | |
|----|--------------------------------------------------------------------------------|----|
| 1 | Terminology and Definitions | 12 |
| 2 | FC-style, H-PBGA Package Dimensions..... | 17 |
| 3 | Terminations: Pull-up/Pull-down..... | 23 |
| 4 | Decoupling Recommendations..... | 34 |
| 5 | Motherboard Stack Up, Stripline and Microstrip | 37 |
| 6 | Adapter Card Stack Up, Microstrip and Stripline | 39 |
| 7 | PCI-X Slot Guidelines..... | 43 |
| 8 | PCI-X Clock Layout Requirements Summary | 46 |
| 9 | PCI-X 133 MHz Single Slot Routing Recommendations | 48 |
| 10 | Embedded PCI-X 133 MHz Routing Recommendations | 49 |
| 11 | Embedded PCI-X 133 MHz Alternate Topology Routing Recommendations..... | 50 |
| 12 | Embedded and Slot PCI-X 133 MHz Routing Recommendations..... | 51 |
| 13 | Embedded and Slot PCI-X 133 MHz Routing Recommendations..... | 52 |
| 14 | PCI-X 100 MHz Slot Topology Routing Recommendations | 53 |
| 15 | PCI-X 100 MHz Embedded Routing Recommendations | 54 |
| 16 | Combination of Slot and Embedded PCI-X 100 MHz Routing Recommendations | 55 |
| 17 | Combination of Slot and Embedded PCI-X 100 MHz Routing 2 Recommendations | 56 |
| 18 | PCI-X 66 MHz Slot Routing Recommendations | 57 |
| 19 | PCI-X 66 MHz Embedded Routing Recommendations | 58 |
| 20 | PCI-X 66 MHz Mixed Mode Routing Recommendations..... | 59 |
| 21 | PCI 66 MHz Slot Table | 60 |
| 22 | PCI 66 MHz Embedded Table | 61 |
| 23 | PCI 66 MHz Mixed Mode Table..... | 62 |
| 24 | PCI 33 MHz Slot Routing Recommendations..... | 63 |
| 25 | PCI 33 MHz Embedded Routing Recommendations | 64 |
| 26 | PCI 33 MHz Mixed Mode Routing Recommendations | 65 |
| 27 | DDR Bias Voltages..... | 67 |
| 28 | DDR II Bias Voltage..... | 67 |
| 29 | Core Speed and Memory Configuration | 68 |
| 30 | Simulated DDR 333 Topologies | 69 |
| 31 | Example Topologies for DDR Trace..... | 71 |
| 32 | x64 DDR Memory Configuration..... | 72 |
| 33 | x72 DDR Memory Configuration..... | 72 |
| 34 | Source Synchronous Termination Requirements..... | 73 |
| 35 | Source Synchronous Routing Recommendations..... | 74 |
| 36 | DIMM DQ/DQS Topology Lengths | 75 |
| 37 | Die to Ball Internal Lengths | 75 |
| 38 | DIMM DQ/DQS Split Termination Topology Lengths | 80 |
| 39 | DIMM Clocked Signal Group Termination | 81 |
| 40 | Clock Signal Group Registered/Unbuffered DIMM Routing Requirements | 82 |
| 41 | Registered DIMM Clock Topology Lengths | 83 |
| 42 | DDR 333 Unbuffered DIMM Clock Topology Lengths..... | 84 |
| 43 | Source Clocked Signal Routing..... | 85 |
| 44 | Control Signals Routing Guidelines..... | 86 |
| 45 | Control Signal DIMM Topology Lengths..... | 88 |
| 46 | DDR 333 Embedded Source Synchronous Routing Recommendations..... | 89 |
| 47 | Embedded DDR 333 DQ/DQS Topology Lengths..... | 91 |
| 48 | DDR 333 Embedded Registered/Unbuffered Clock Routing Recommendations..... | 93 |

| | | |
|----|--------------------------------------------------------------------------|-----|
| 49 | Embedded DDR 333 Buffered Clock Topology Lengths | 94 |
| 50 | Embedded DDR 333 Unbuffered Clock Topology Lengths | 95 |
| 51 | DDR 333 Embedded Address/Command Routing Recommendations | 96 |
| 52 | Embedded DDR 333 Unbuffered Address/CMD Topology Lengths | 98 |
| 53 | Embedded DDR 333 Registered Address/CMD Topology Lengths | 99 |
| 54 | x64 DDR Memory Configuration | 101 |
| 55 | x72 DDR Memory Configuration | 101 |
| 56 | DDR II Topologies Simulated | 102 |
| 57 | Example Topology for DDRII Trace Width/Impedance Requirements | 103 |
| 58 | DDRII 400 DIMM Source Synchronous Routing Recommendations | 105 |
| 60 | DDR II 400 DIMM DQS Lengths | 106 |
| 59 | DDR II 400 DIMM DQ Lengths | 106 |
| 61 | DDRII 400 DIMM Clock Routing Recommendations | 107 |
| 62 | DDR II 400 DIMM Clock Lengths | 107 |
| 63 | DDRII 400 DIMM Address/Command/Control Routing Recommendation | 108 |
| 64 | DDR II 400 DIMM Address/CMD Lengths | 109 |
| 65 | DDRII 400 Embedded Source Synchronous Routing Recommendations | 110 |
| 66 | DDR II 400 Embedded DQ Lengths | 111 |
| 67 | DDR II 400 Embedded DQS Lengths | 112 |
| 68 | DDRII 400 Embedded Clock Routing Recommendations | 113 |
| 69 | DDR II 400 Embedded Clock (PLL) Lengths | 114 |
| 70 | DDRII 400 Embedded Address/Command/Control Routing Recommendations | 116 |
| 71 | DDR II 400 Embedded Address/CMD Lengths | 117 |
| 72 | Flash Wait State Profile Programming | 125 |
| 73 | Routing Guideline Bidirectional Single Load | 127 |
| 74 | Routing Guideline Latched Bidirectional Latch Single Load | 128 |
| 75 | Routing Guideline Latch Bidirectional Two Loads | 129 |
| 76 | Intel® 80331 I/O Processor Bias Voltages | 131 |
| 77 | Four Peaks Customer Reference Board Features | 138 |
| 78 | Logic Analyzer Pod 1 | 143 |
| 80 | Logic Analyzer Pod 3 | 144 |
| 79 | Logic Analyzer Pod 2 | 144 |
| 82 | Logic Analyzer Pod 5 | 145 |
| 81 | Logic Analyzer Pod 4 | 145 |
| 83 | Logic Analyzer Pod 6 | 146 |
| 84 | Design References | 147 |
| 85 | Intel Related Documentation | 147 |
| 86 | Electronic Information | 148 |

Revision History

| Date | Revision | Description |
|----------------|----------|-------------------------------------------------------------------------------------------------------------------------------------------------------------------------------------------------------------------------------------------------------------------------------------------------------------------------------------------------------------------------------------------------------------------------------------------------------------------------------------------------------------------------------------------------------------------------------------------------------------------------------------------------------------------------------------------------------------------------------------------------------------------------------------------------------------------------------------------------------------------------------------------------------------------------------------------------------------------------------------------------------------------------------------------------------------------------------------------------------------------------------------------------------------------------------------------------------------------------------------------------------------------------------------------------------------------------------------------------------------------------------------------------------------------------------------------------------------------------------------------------------------------------------------------------------------------------------------------------------------------------------------------------------------------------------------------------------------------------------------------------------------------------------------------------------------------------------------------------------------------------------------------------------------------------------------------------------------------------------------------------------------------------------------------------------------------------------|
| March 2005 | 003 | Updated Figure 27 , Figure 33 , and Figure 49 . |
| October 2004 | 002 | <p>In Chapter 6:</p> <p>Table 8: added row Preferred Topology: stripline</p> <p>Table 8: changed Clock Layout Requirements Add-in card impedance from 60 ohms to 57 ohms.</p> <p>Changed topology information in Figure 24 and Table 16.</p> <p>Table 17 Added alternate PCI-X 100MHz Slot and Embedded Topology Figure 25 and Table 16.</p> <p>Table 18 Changed Add-in card impedance from 60 ohms +/- 15% to 57 ohms +/- 15%.</p> <p>In Chapter 7:</p> <p>DDR 333 Source Synchronous recommendations removed the requirement for length matching for DQS groups based on simulations</p> <p>Removed row in Table 48 "Length Matching Requirements: between clock groups". This is required only for unbuffered clocks and was already mentioned in the previous row.</p> <p>Table 51: removed row in "Trace Length: 80331 signal Ball to Series Termination" because the series termination is no longer needed.</p> <p>Table 52: Removed Routing Guideline 4 because unbuffered and registered DIMM's have the same topology.</p> <p>Deleted Figure 57 because simulations showed that series resistors is no longer needed for DDR 333 DIMM control signals</p> <p>Table 53: Removed Length Matching within DQS group recommendation now because length matching will happen when matching to M_CK.</p> <p>Changed Embedded DDR 333 DQ/DQS Topology Figure 44 resistor listed as 50 ohms +/- 5% to 51 ohms +/- 5% because this is a standard value resistor.</p> <p>In Chapter 9</p> <p>Removed VCC25/VCC18 from the power up sequence order and added a note stating that there is no sequence order requirements for the VCC25 or VCC18 rail.</p> <p>Other:</p> <p>Moved the decoupling guidelines from Chapter 3 to Chapter 4.</p> <p>Removed reference to the Hot Plug controller. This feature is not part of the 80331 product.</p> |
| September 2003 | 001 | Initial Release. |

Introduction

1

1.1 About This Document

This document provides layout information and guidelines for designing platform or add-in board applications with the Intel® 80331 I/O processor (80331), which is ARM* architecture compliant. It is recommended that this document be used as a guideline. Intel recommends employing best-known design practices with board level simulation, signal integrity testing and validation for a robust design.

Designers please note that this guide focuses upon specific design considerations for the 80331 and is not intended to be an all-inclusive list of all good design practices. Use this guide as a starting point and use empirical data to optimize your particular design.

Intel Corporation assumes no responsibility for any errors which may appear in this document nor does it make a commitment to update the information contained herein.

Intel retains the right to make changes to these specifications at any time, without notice. In particular, descriptions of features, timings, packaging, and pin-outs does not imply a commitment to implement them. In fact, this specification does not imply a commitment by Intel to design, manufacture, or sell the product described herein.

1.1.1 Terminology and Definitions

Table 1. Terminology and Definitions (Sheet 1 of 2)



| Term | Definition | |
|------------------------|----------------------------------------------------------------------------------------------------------------------------------------------------------------------------------------------------------------------------------------------------------------------------------------------------------------------------------------------------------------------------------------------------|------------------------------------------------------------------------------------------------------------------------------------------------------------------------------------------------------------------------------------------------------------------------------------------------------------------------------------------------------------------------------------------------------------------------------------------------------------------------------|
| 80331 | Intel® 80331 I/O processor | |
| Stripline |  | <p>Stripline in a PCB is composed of the conductor inserted in a dielectric with GND planes to the top and bottom.</p> <p>NOTE: An easy way to distinguish stripline from microstrip is that you need to strip away layers of the board to view the trace on stripline.</p> |
| Microstrip |  | <p>Microstrip in a PCB is composed of the conductor on the top layer above the dielectric with a ground plane below</p> |
| Prepreg | Material used for the lamination process of manufacturing PCBs. It consists of a layer of epoxy material that is placed between two cores. This layer melts into epoxy when heated and forms around adjacent traces. | |
| Core | Material used for the lamination process of manufacturing PCBs. This material is two sided laminate with copper on each side. The core is an internal layer that is etched. | |
| PCB |  <p>Layer 1: copper Prepreg Layer 2: GND</p> <p>Core</p> <p>Layer 3: V_{CC} Prepreg Layer 4: copper</p> <p>Example of a Four-Layer Stack</p> | <p>Printed circuit board.</p> <p>Example manufacturing process consists of the following steps:</p> <ul style="list-style-type: none"> • Consists of alternating layers of core and prepreg stacked • The finished PCB is heated and cured. • The via holes are drilled • Plating covers holes and outer surfaces • Etching removes unwanted copper • Board is tinned, coated with solder mask and silk screened |
| DDR | Double Data Rate Synchronous DRAM. Data is clocked on both rising and falling edges of the clock. | |
| DDR II | DDR II is backward compatible with DDR I. However, it has an increased DDR data rate to 3.2 GBytes/sec with a clock rate of 200 MHz for multiple DIMM configurations. It allows data rate of 6.4 Gbytes/sec with a clock rate of 400 MHz for a single DIMM point to point configuration. | |
| DIMM | Dual Inline Memory Module | |
| Source Synchronous DDR | <ul style="list-style-type: none"> • For reads data leaves the DDR or memory controller with a data strobe. The memory controller delays the data strobe internally to line it up with the data valid window. • For writes the memory controller places the data strobe in the middle of the data valid window to ensure that the correct data gets clocked into the DRAM. | |
| SSTL_2 | Series Stub Terminated Logic for 2.5 V | |
| JEDEC | Provides standards for the semiconductor industry. | |
| DLL | Delay Lock Loop - refers to the DDR feature used to provide appropriate strobe delay to clock in data. | |

Table 1. Terminology and Definitions (Sheet 2 of 2)

| Term | Definition |
|-----------------|-------------------------------------------------------------------------------------------------------------------------------------------------------------------------------------------------------------------------------------------------------------------------------------------------------------------------------------------------------------------------------------------------------------------------------------------------------------------------------------------------------------------------------------------------------------------------------------|
| Aggressor | <p>A network that transmits a coupled signal to another network is aggressor network.</p>  |
| Victim | A network that receives a coupled cross-talk signal from another network is a victim network. |
| Network | The trace of a PCB that completes an electrical connection between two or more components. |
| Stub | Branch from a trunk terminating at the pad of an agent. |
| ISI | <p>Intersymbol Interference (ISI). This occurs when a transition that has not been completely dissipated, interferes with a signal being transmitted down a transmission line. ISI can impact both the timing and signal integrity. It is dependent on frequency, time delay of the line and the reflection coefficient at the driver and receiver. Examples of ISI patterns that could be used in testing at the maximum allowable frequencies are the sequences shown below:</p> <p style="text-align: center;">0101010101010101 0011001100110011 0001110001110001111</p> |
| CRB | Customer Reference Board |
| PC1600 | <p>JEDEC Names for DDR based on peak data rates. PC1600= clock of 100 MHz * 2 data words/clock * 8 bytes = 1600 MB/sec</p> |
| PC2100 | <p>JEDEC Names for DDR based on peak data rates. PC2100= clock of 133 MHz * 2 data words/clock * 8 bytes = 2128 MB/sec</p> |
| PC2700 | <p>JEDEC Names for DDR II based on peak data rates. PC2700= clock of 167 MHz * 2 data words/clock * 8 bytes = 2672 MB/sec</p> |
| PC3200 | <p>JEDEC Names for DDR II based on peak data rates. PC3200= clock of 200 MHz * 2 data words/clock * 8 bytes = 3200 MB/sec</p> |
| Downstream | At or toward the Primary PCI interface from the Secondary PCI interface |
| Local memory | Memory subsystem on the Intel XScale® core DDR SDRAM or Peripheral Bus Interface busses. |
| DWORD | 32-bit data word. |
| Local bus | 80331 Internal Bus. |
| Outbound | At or toward the PCI interface of the 80331 ATU from the Internal Bus. |
| Inbound | At or toward the Internal Bus of the 80331 from the PCI interface of the ATU. |
| Local processor | Intel XScale® core within the 80331. |
| Core processor | Intel XScale® core within the 80331. |
| Flip Chip | FC-BGA (flip chip-ball grid array) chip packages are designed with core flipped up on the back of the chip, facing away from the PCB. This allows more efficient cooling of the package. |
| Mode Conversion | Mode Conversions are due to imperfections on the interconnect which transform differential mode voltage to common mode voltage and common mode voltage to differential voltage. |
| ROMB | Raid on motherboard |
| ODT | On Die Termination - eliminates the need for termination resistors by placing the termination at the chip. |

1.1.2 Other Relevant Documents

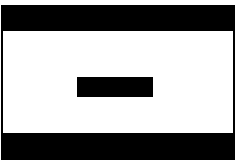
1. *Intel® 80331 I/O Processor Specification Update (273930)*, Intel Corporation
2. *Intel® 80331 I/O Processor Datasheet (273943)*, Intel Corporation
3. *Intel® 80331 I/O Processor Developer's Manual (273942)*, Intel Corporation
4. *Intel XScale® 80200 Processor based on Intel® Microarchitecture Developer's Manual (273411)*, Intel Corporation
5. *PCI Local Bus Specification*, Revision 2.3 - PCI Special Interest Group
6. *PCI-X Specification*, Revision 1.0b - PCI Special Interest Group
7. *PCI Bus Power Management Interface Specification*, Revision 1.1 - PCI Special Interest Group
8. *IEEE Standard Test Access Port and Boundary-Scan Architecture (IEEE JTAG-1149.1-1990)*

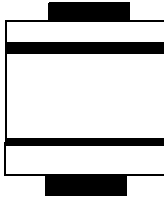
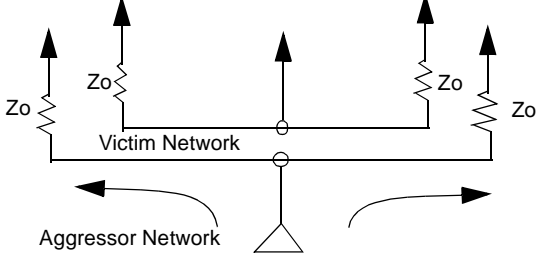
1.2 About the Intel® 80331 I/O Processor

The 80331 is a multi-function device that integrates the Intel XScale® core (ARM* architecture compliant) with intelligent peripherals and PCI-to-PCI Bridge. The 80331 consolidates the following into a single system:

- Intel XScale® core
- PCI-to-PCI Bridge supporting PCI-X interfaces on the Primary and Secondary bus.
- Address Translation Unit (PCI-to-Internal Bus Application Bridge) interfaced to the Secondary Bus
- High-Performance Memory Controller
- Interrupt Controller with up to 13 external interrupt inputs
- Two Direct Memory Access (DMA) Controllers
- Application Accelerator
- Messaging Unit
- Peripheral Bus Interface Unit
- Performance Monitor
- Two I²C Bus Interface Units
- Two 16550 compatible UARTs with flow control (four pins)
- Eight General Purpose Input Output (GPIO) ports

It is an integrated processor that addresses the needs of intelligent I/O applications and helps reduce intelligent I/O system costs.

Figure 1 provides a block diagram of the 80331.

Figure 1. Intel® 80331 I/O Processor Functional Block Diagram

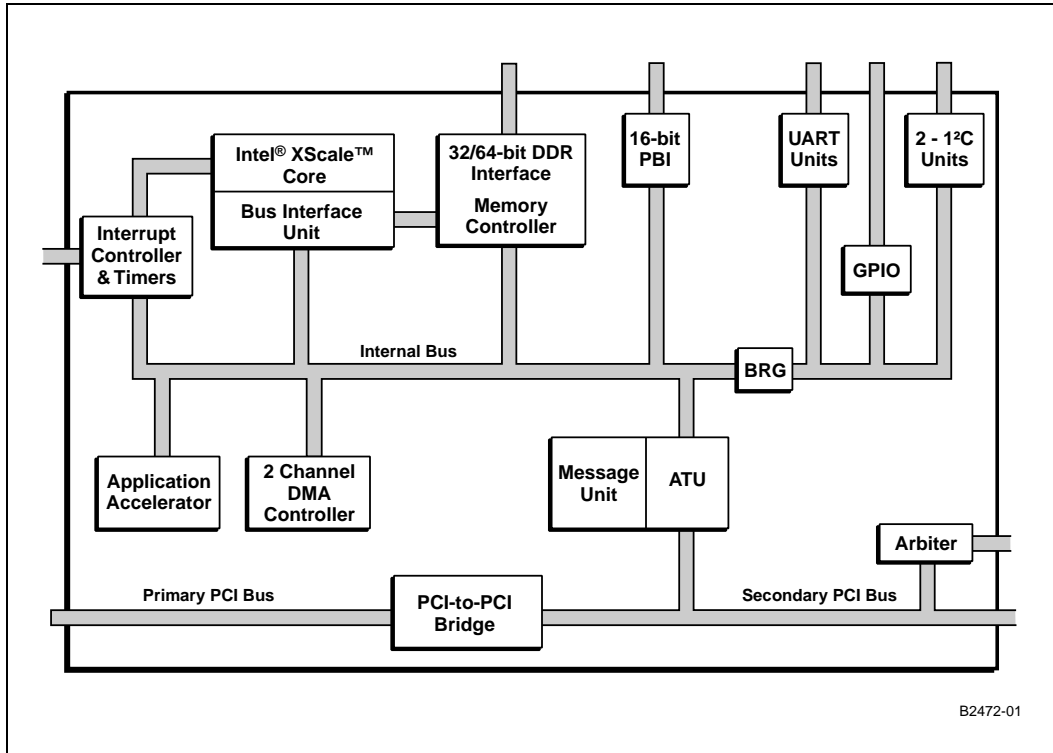

Package Information

2

The 80331 is offered in a Flip Chip Ball Grid Array (FCBGA) package. This is a full-array package with 829 ball connections. The mechanical dimensions for this package are provided in the figure below and [Table 2](#). [Figure 3](#) and [Figure 4](#) show the 829 pins of the Flip Chip Ball Grid Array (FCBGA), mapped by pin function. This diagram is helpful in placing components around the 80331 for the layout of a PCB. To simplify routing and minimize the number of cross traces, keep this layout in mind when placing components on your board. The signals, by design, are located on the FCBGA package to simplify signal routing and system implementation.

Table 2. FC-style, H-PBGA Package Dimensions

| 829-Pin BGA | | |
|-------------|------------|---------|
| Symbol | Minimum | Maximum |
| A | 2.392 | 2.942 |
| A1 | 0.50 | 0.70 |
| A3 | 0.742 | 0.872 |
| b | 0.61 Ref. | |
| C | 1.15 | 1.37 |
| D | 37.45 | 37.55 |
| E | 37.45 | 37.55 |
| F1 | 9.88 Ref. | |
| F2 | 10.16 Ref. | |
| e | 1.27 Ref. | |
| S1 | 0.97 Ref. | |
| S2 | 0.97 Ref. | |

NOTE: Measurement in millimeters.

Figure 2. Intel® 80331 I/O Processor 829-Ball FCBGA Package Diagram

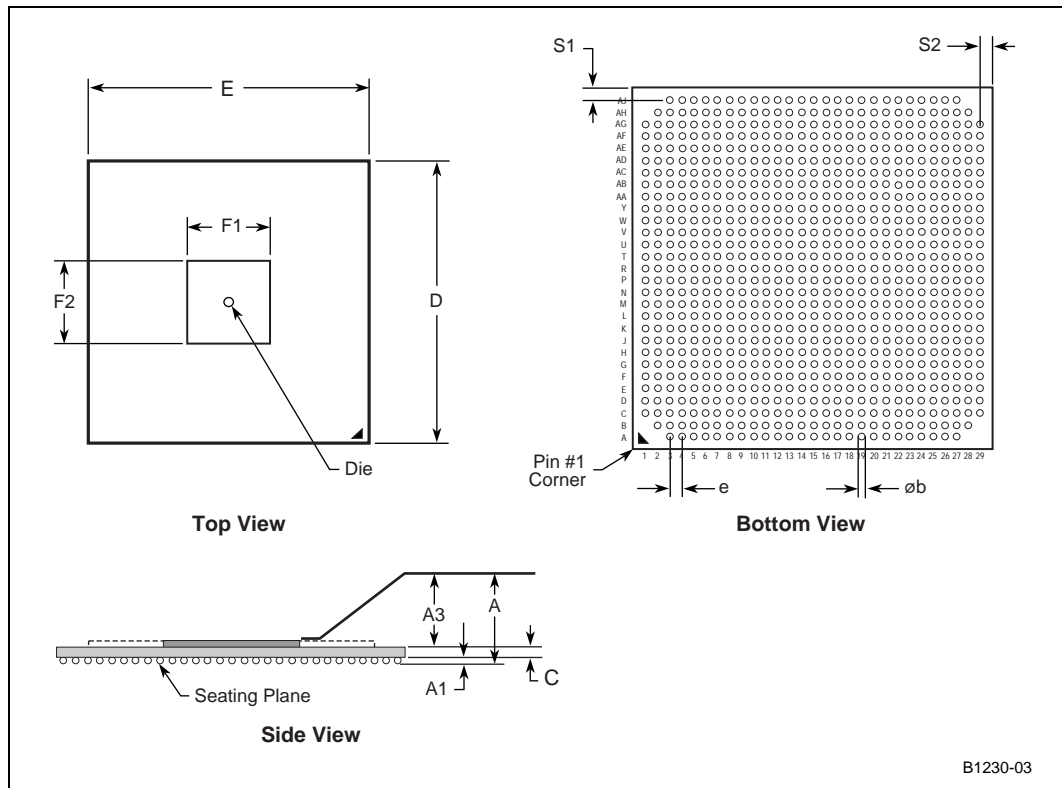

Figure 3. Intel® 80331 I/O Processor Preliminary Ballout (Top View)

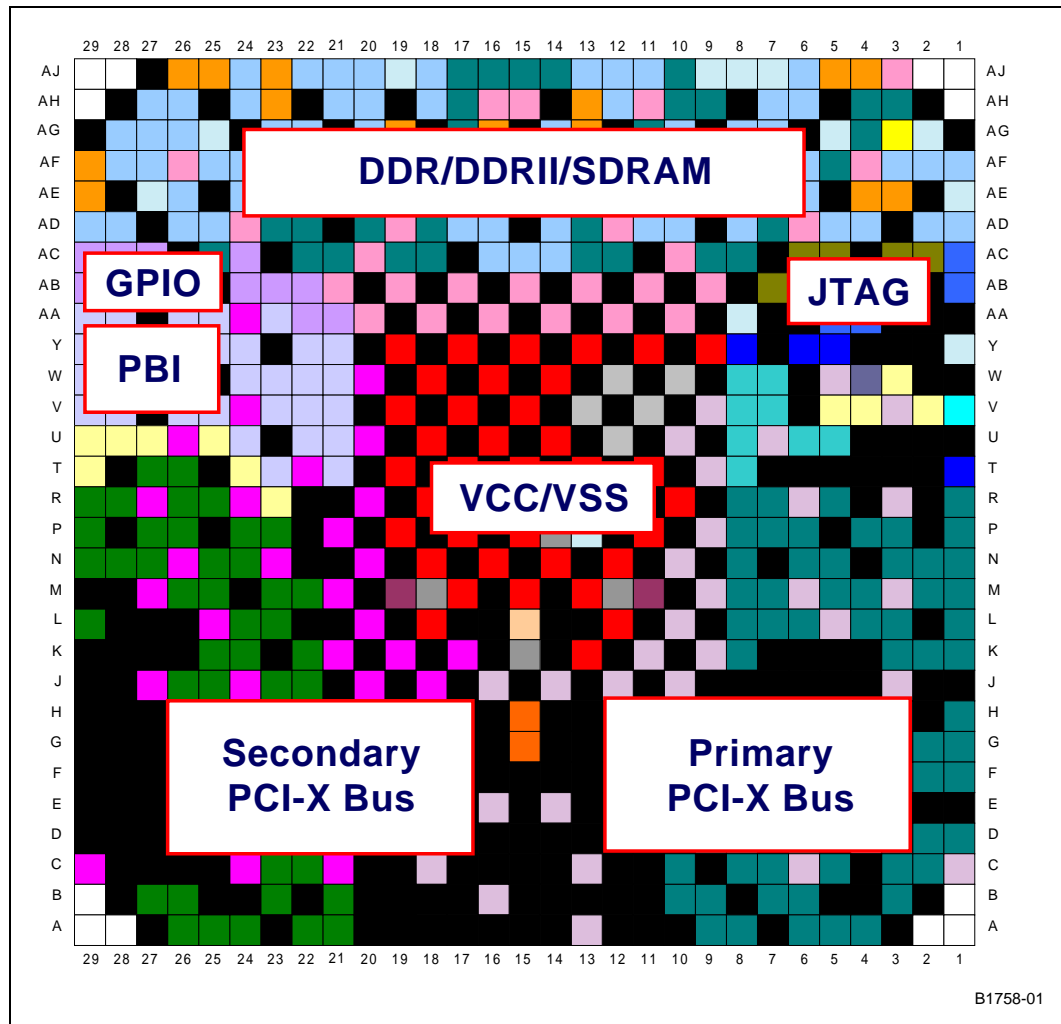
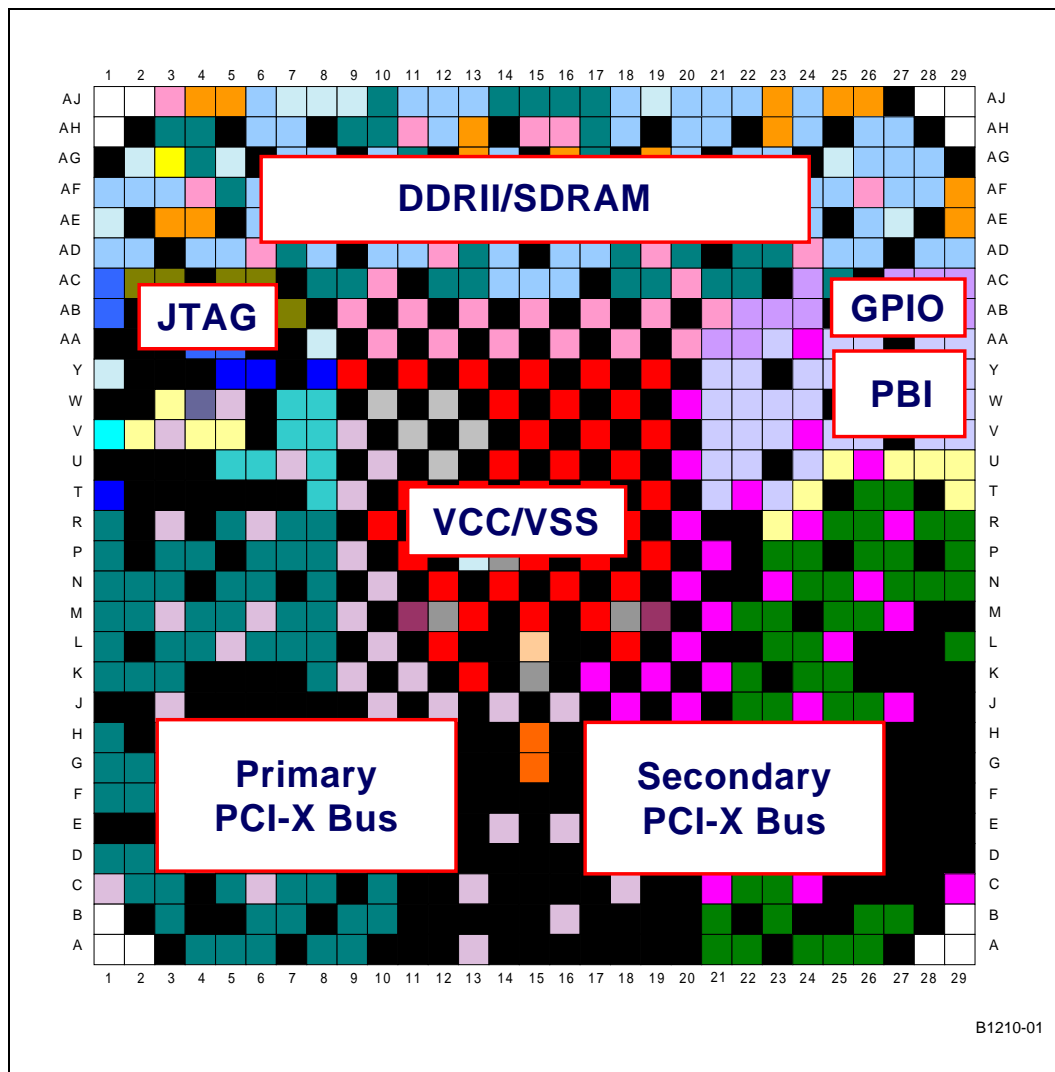

Figure 4. Intel® 80331 I/O Processor Preliminary Ballout (Bottom View)



2.1 Power Plane Layout

Figure 5 provides an example of how the 80331 DDR, CPU core and 1.5 V core power planes are partitioned on the Intel® IQ80331 Evaluation Platform Board (IQ80331).

Note: The voltage for the secondary PCIX bus and primary PCIX bus can be on the same plane.

Figure 5. Intel® 80331 I/O Processor Power Plane Layout

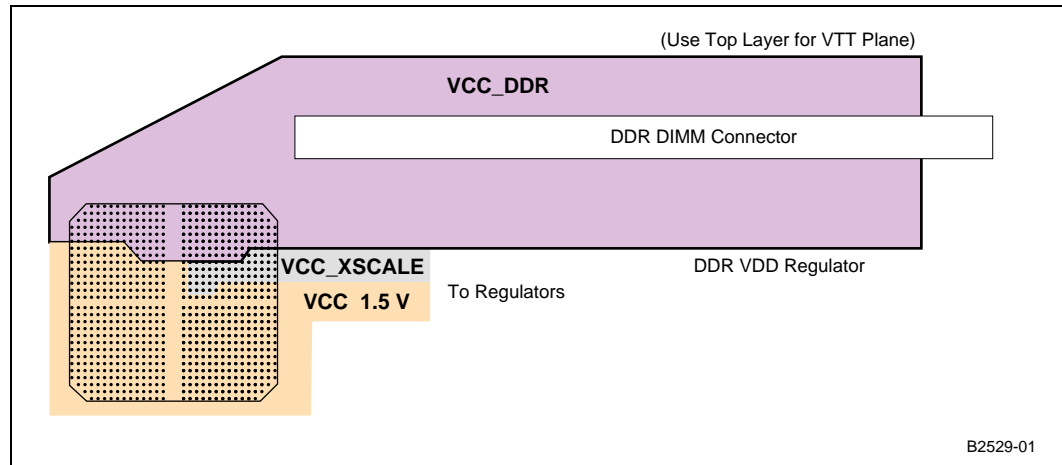

2.2 Intel® 80331 I/O Processor Applications

This section provides a block diagram of a 80331 Serial ATA adapter card application. This entire SATA RAID card adapter can be implemented with just a few chips using the 80331 integrated PCI-X bridge and IO processing capability.

Figure 6. Intel® 80331 I/O Processor PCI-X Adapter Card Block Diagram

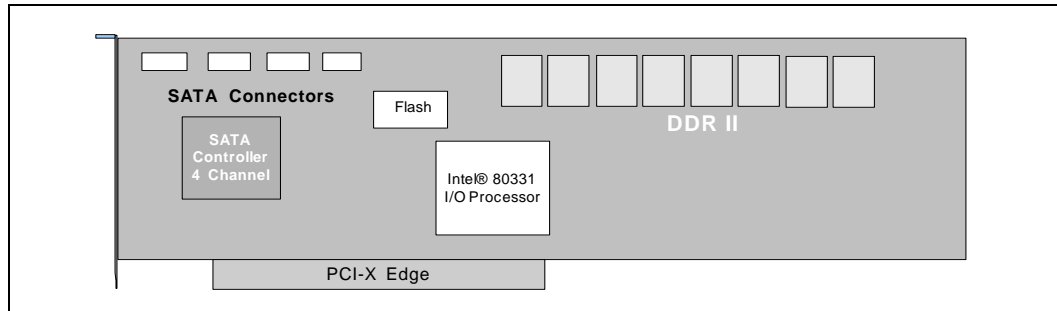

Terminations

3

This chapter provides the recommended pull-up and pull-down terminations for a 80331 layout. [Table 3](#) lists these 80331 termination values. On a motherboard, the *PCI Local Bus Specification*, Revision 2.3 requires that the PCI signals provide the termination resistors. Pull-ups on the PCI signals are not required with `PCIODT_EN = 1` (enabled), because they are implemented on the die. Refer to the [Table 3](#) for more information.

Table 3. Terminations: Pull-up/Pull-down (Sheet 1 of 4)

| Signal | Pull-up or Pull-down Resistor Value (in Ohms) | Comments |
|-----------------|--------------------------------------------------------------------------------------------------------------------------------------------------------------------------------------------------------------------------------------------------------------------------------------------------|-------------------------------------------------------------------------------------------------------------------------------------------------------------------------------------------------------------------------------------------------------------------------------------------------------------------------------|
| PWRDELAY | <p>If battery backup is implemented:</p> <ul style="list-style-type: none"> 1.5 K pull-up to 3.3 V is required on PWRDELAY. <p>Battery Backup not implemented:</p> <ul style="list-style-type: none"> This pin can be permanently pulled low with a 1.5K pull-down | |
| TRST# | 1.5K pull-down* | <p>NOTES:</p> <ul style="list-style-type: none"> Alternatively tied to P_RST# refer to Section 11.4.2, "ARM Multi-ICE" on page 142 for more information about using with a ICE. When not used this signal is be tied to GND. This pin has an internal pull-up. |
| TMS | NC when not being used (has internal pull-up) | |
| TDI | NC when not being used (has internal pull-up) | |
| TCK | 1.5K pull-down when not used | |
| GPIO[0]/U0_RXD | 8.2 K pull-up | Note: GPIO[7:0] initializes as inputs on assertion of P_RST# . |
| GPIO[1]/U0_TXD | 8.2 K pull-up | Note: GPIO[7:0] initializes as inputs on assertion of P_RST# . |
| GPIO[2]/U0_CTS# | 8.2 K pull-up | Note: GPIO[7:0] initializes as inputs on assertion of P_RST# . |
| GPIO[3]/U0_RTS# | 8.2 K pull-up | Note: GPIO[7:0] initializes as inputs on assertion of P_RST# . |
| GPIO[4]/U1_RXD | 8.2 K pull-up | Note: GPIO[7:0] initializes as inputs on assertion of P_RST# . |
| GPIO[5]/U1_TXD | 8.2 K pull-up | Note: GPIO[7:0] initializes as inputs on assertion of P_RST# . |
| GPIO[6]/U1_CTS# | 8.2 K pull-up | Note: GPIO[7:0] initializes as inputs on assertion of P_RST# . |
| GPIO[7]/U1_RTS | 8.2 K pull-up | Note: GPIO[7:0] initializes as inputs on assertion of P_RST# . |
| ARB_EN | (see comments) | This signal has been defeatured. Please refer to the Intel® 80331 Specification Update for more information. |

Table 3. Terminations: Pull-up/Pull-down (Sheet 2 of 4)

| Signal | Pull-up or Pull-down Resistor Value (in Ohms) | Comments |
|--------------|-----------------------------------------------|-------------------------------------------------------------------------------------------------------------------------------------------------------------------------------------------------------------------------------------------------------------------------------------------------------------------------------------------------------------------------------------------------------------------------------------------------------------------------------------------------------------------------------------------------------------------------------------------------------------------------------------------------------------------------------------------------|
| PCIODT_EN | 1.5 K pull-down when needed (see comments) | <p>PCI Bus ODT Enable: is latched on the rising (deasserting) edge of P_RST#, and determines when the PCI-X interface has On Die Termination enabled valid on the secondary PCI bus only.</p> <ul style="list-style-type: none"> 0 = ODT disabled on the secondary PCI bus. (Requires pull-down resistor). 1 = ODT enabled on the secondary PCI bus. (Default mode). <p>This signal controls termination for the following signals: S_AD[63:32], S_C/BE[7:4]#, S_PAR64, S_REQ64#, S_REQ[3:0]#, S_ACK64#, S_FRAME#, S_IRDY#, S_DEVSEL#, S_TRDY#, S_STOP#, S_PERR#, S_LOCK#, S_M66EN, S_SERR# and XINT[3:0]#</p> <p>NOTE: This signal is muxed onto signal A[20].</p> |
| P_32BITPCI# | 1.5 K pull-down when needed (see comments) | <p>Primary PCI-X Bus Width: By default, identifies 80331 subsystem as 64-bit unless user attaches appropriate pull-down resistor.</p> <p>0 = 32 bit wide bus. (Requires pull-down resistor). 1 = 64 bit wide bus. (Default mode).</p> <p>NOTE: Muxed onto signal A[2]</p> |
| S_INT[D:A]#. | Refer to comments | <ul style="list-style-type: none"> When PCIODT_EN = 1 no external pull-up needed When PCIODT_EN = 0, then 8.2 K pull-up is required. |
| S_LOCK# | Refer to comments | <ul style="list-style-type: none"> When PCIODT_EN = 1 no external pull-up needed When PCIODT_EN = 0, then 8.2 K pull-up is required. |
| S_SERR# | Refer to comments | <ul style="list-style-type: none"> When PCIODT_EN = 1 no external pull-up needed When PCIODT_EN = 0, then 8.2 K pull-up is required. |
| S_TRDY# | Refer to comments | <ul style="list-style-type: none"> When PCIODT_EN = 1 no external pull-up needed When PCIODT_EN = 0, then 8.2 K pull-up is required. |
| S_PERR# | Refer to comments | <ul style="list-style-type: none"> When PCIODT_EN = 1 no external pull-up needed When PCIODT_EN = 0, then 8.2 K pull-up is required. |
| S_DEVSEL# | Refer to comments | <ul style="list-style-type: none"> When PCIODT_EN = 1 no external pull-up needed When PCIODT_EN = 0, then 8.2 K pull-up is required. |
| S_FRAME# | Refer to comments | <ul style="list-style-type: none"> When PCIODT_EN = 1 no external pull-up needed When PCIODT_EN = 0, then 8.2 K pull-up is required. |
| S_STOP# | Refer to comments | <ul style="list-style-type: none"> When PCIODT_EN = 1 no external pull-up needed When PCIODT_EN = 0, then 8.2 K pull-up is required. |
| S_IRDY# | Refer to comments | <ul style="list-style-type: none"> When PCIODT_EN = 1 no external pull-up needed When PCIODT_EN = 0, then 8.2 K pull-up is required. |
| S_AD[63:32] | Refer to comments | <ul style="list-style-type: none"> When PCIODT_EN = 1 no external pull-up needed When PCIODT_EN = 0, then 8.2 K pull-up is required. |
| S_C/BE[7:4] | Refer to comments | <ul style="list-style-type: none"> When PCIODT_EN = 1 no external pull-up needed When PCIODT_EN = 0, then 8.2 K pull-up is required. |
| S_PAR64 | Refer to comments | <ul style="list-style-type: none"> When PCIODT_EN = 1 no external pull-up needed When PCIODT_EN = 0, then 8.2 K pull-up is required. |
| S_REQ64# | Refer to comments | <ul style="list-style-type: none"> When PCIODT_EN = 1 no external pull-up needed When PCIODT_EN = 0, then 8.2 K pull-up is required. |
| S_ACK64# | Refer to comments | <ul style="list-style-type: none"> When PCIODT_EN = 1 no external pull-up needed When PCIODT_EN = 0, then 8.2 K pull-up is required. |
| S_M66EN | Refer to comments | <ul style="list-style-type: none"> When PCIODT_EN = 1 no external pull-up needed When PCIODT_EN = 0, then 8.2 K pull-up is required when PCI bus is to operate at 66 MHz. This signal is grounded for 33 MHz operation. |

Table 3. Terminations: Pull-up/Pull-down (Sheet 3 of 4)

| Signal | Pull-up or Pull-down Resistor Value (in Ohms) | Comments |
|-------------|-------------------------------------------------|--------------------------------------------------------------------------------------------------------------------------------------------------------------------------------------------------------------------------------------------------------------------------------------------------------------------------------------------------------------------------------------------------------------------------------------------|
| S_RCOMP | 100 ohm +/- 1% to GND | |
| SCLKIN | Through 33.2ohm resistor to S_CLKOUT | |
| S_REQ[3:0]# | Refer to comments | <ul style="list-style-type: none"> When PCIODT_EN = 1 no external pull-up needed When PCIODT_EN = 0, then 8.2 K pull-up is required. |
| S_PCIXCAP | Refer to comments | 66 MHz PCI: connect pin to GND. 66 MHz PCI-X: use 0.01 μF to GND 10 K resistor to GND. 100 MHz PCI-X: use 0.01 μF to GND. 133 MHz PCI-X: use 0.01 μF to GND. ¹ |
| PRIVMEM | 1.5 K pull-down when needed (refer to comments) | Private Memory Enable: PRIVMEM latched at rising (deasserting) edge of P_RST# and determines when the 80331 operates with Private Memory Space on the secondary PCI bus of the PCI-to-PCI Bridge. 0 = Normal addressing mode. Requires pull-down resistor. 1 = Private Addressing enable in PCI-to-PCI Bridge. (Default mode) Muxed onto signal A[1] , |
| PRIVDEV | 1.5 K pull-down when needed (refer to comments) | Private Device Enable: PRIVDEV latched at rising (deasserting) edge of P_RST# and determines when the 80331 operates with Private Device enabled on the secondary PCI bus of the PCI-to-PCI Bridge. 0 = All Secondary PCI devices are accessible to Primary PCI configuration cycles. (Requires pull-down resistor). 1 = Private Devices enabled in PCI-to-PCI Bridge. (Default mode) Muxed onto signal A[0] |
| P_RCOMP | 100 ohm +/- 1% to GND | |
| P_REQ# | Refer to comments | 8.2 K pull-up is required when not already pulled up on the PCI bus. An add-in card may rely on the motherboard to pull-up this signal. |
| P_LOCK# | Refer to comments | 8.2 K pull-up is required when not already pulled up on the PCI bus. An add-in card may rely on the motherboard to pull-up this signal. |
| P_SERR# | Refer to comments | 8.2 K pull-up is required when not already pulled up on the PCI bus. An add-in card may rely on the motherboard to pull-up this signal. |
| P_TRDY# | Refer to comments | 8.2 K pull-up is required when not already pulled up on the PCI bus. An add-in card may rely on the motherboard to pull-up this signal. |
| P_PERR# | Refer to comments | 8.2 K pull-up is required when not already pulled up on the PCI bus. An add-in card may rely on the motherboard to pull-up this signal. |
| P_DEVSEL# | Refer to comments | 8.2 K pull-up is required when not already pulled up on the PCI bus. An add-in card may rely on the motherboard to pull-up this signal. |
| P_FRAME# | Refer to comments | 8.2 K pull-up is required when not already pulled up on the PCI bus. An add-in card may rely on the motherboard to pull-up this signal. |
| P_STOP# | Refer to comments | 8.2 K pull-up is required when not already pulled up on the PCI bus. An add-in card may rely on the motherboard to pull-up this signal. |
| P_IRDY# | Refer to comments | 8.2 K pull-up is required when not already pulled up on the PCI bus. An add-in card may rely on the motherboard to pull-up this signal. |
| P_AD[63:32] | Refer to comments | 8.2 K pull-up is required when not already pulled up on the PCI bus. An add-in card may rely on the motherboard to pull-up this signal. |
| P_C/BE[7:4] | Refer to comments | 8.2 K pull-up is required when not already pulled up on the PCI bus. An add-in card may rely on the motherboard to pull-up this signal. |
| P_PAR64 | Refer to comments | 8.2 K pull-up is required when not already pulled up on the PCI bus. An add-in card may rely on the motherboard to pull-up this signal. |
| P_REQ64# | Refer to comments | 8.2 K pull-up is required when not already pulled up on the PCI bus. An add-in card may rely on the motherboard to pull-up this signal. |
| P_ACK64# | Refer to comments | 8.2 K pull-up is required when not already pulled up on the PCI bus. An add-in card may rely on the motherboard to pull-up this signal. |

Table 3. Terminations: Pull-up/Pull-down (Sheet 4 of 4)

| Signal | Pull-up or Pull-down Resistor Value (in Ohms) | Comments |
|-------------------------|-----------------------------------------------------------------------------------------------------------------------------------------------------------------------------------------------------------|-----------------------------------------------------------------------------------------------------------------------------------------------------------------------------------------------------------------------------------------------------------------------------------------------------------------------------------------------------------------------------------------------------------------------------------------------------------------------------------------------------------------|
| P_M66EN | Refer to comments | 8.2 K pull-up is required when not already pulled up on the PCI bus. An add-in card may rely on the motherboard to pull-up this signal. |
| P_REQ# | Refer to comments | 8.2 K pull-up is required when not already pulled up on the PCI bus. An add-in card may rely on the motherboard to pull-up this signal. |
| M_CK[2:0], M_CK# [2:0]# | Refer to comments | For M_CKs and M_CK#s not used leave these pins unconnected. |
| DQS[8:0]# | Refer to Comments | When not in DDRII mode these signals are NC's |
| DDRRES[2:1] | <ul style="list-style-type: none"> Refer to Figure 8 for the recommended termination for DDRII mode. When not in DDRII mode these signals have a 1.0 K pull-down. | |
| HPI# | 8.2 K pull-up | |
| P_BOOT16# | 1.5 K pull-down when needed (refer to comments) | <p>Bus Width is latched on the rising (asserting) edge of P_RST#, it sets the default bus width for the PBI Memory Boot window:</p> <ul style="list-style-type: none"> 0 = 16 bits wide (Requires a pull-down resistor.) 1 = 8 bits wide (Default mode) <p>Muxed onto signal AD[4].</p> |
| MEM_TYPE | 1.5 K pull-down when needed (refer to comments) | <p>Memory Type: MEM_TYPE is latched on the rising (asserting) edge of P_RST# and it defines the speed of the DDR SDRAM interface.</p> <p>0 = DDR-II SDRAM at 400 MHz (Required pull-down resistor.) 1 = DDR SDRAM at 333 MHz (Default mode)</p> <p>Muxed onto signal AD[2]</p> |
| RETRY | 1.5 K pull-down when needed (refer to comments) | <p>Configuration Retry Mode: RETRY is latched on the rising (asserting) edge of P_RST# and determines when PCI interface of the ATU disables PCI configuration cycles by signaling a retry until the configuration cycle retry bit is cleared in the PCI configuration and status register.</p> <p>0 = Configuration Cycles enabled (Requires pull down resistor.) 1 = Configuration Retry enabled in the ATU and the Configuration. (Default mode)</p> <p>Muxed onto signal AD[6]</p> |
| CORE_RST# | 1.5 K pull-down when needed (refer to comments) | <p>Core Reset Mode is latched on the rising (asserting) edge of P_RST# and determines when the Intel® XScale™ core is held in reset until the processor reset bit is cleared in PCI configuration and status register.</p> <p>0 = Hold in reset. (Requires pull-down resistor.) 1 = Do not hold in reset. (Default mode)</p> <p>Muxed onto signal AD[5]</p> |
| BRG_EN | 1.5 K pull-down when needed (refer to comments) | <p>Bridge Enable: BRG_EN latched at rising (deasserting) edge of P_RST# and determines when the 80331 operates with PCI-to-PCI Bridge.</p> <p>0 = Disable Bridge, enable P_CLK input on S_CLKIN input. (Requires pull-down resistor) 1 = Enabled Bridge. (Default mode)</p> <p>Muxed onto signal AD[0]</p> |
| DDRSLWCRES | Refer to Figure 9 | |
| DDRIMPCRES | Refer to Figure 9 | |
| ODT[1:0] | Connect to ODT on DIMM terminated with 49.9 ohm resistor to VTT | When not used this pin is left as a "no connect". |

3.1 Analog Filters

The following section describes filters needed for biasing PLL circuitry.

3.1.1 V_{CCPLL} Pin Requirements

To reduce clock skew, the V_{CCPLL} balls for the Phase Lock Loop (PLL) circuit are isolated on the package. The lowpass filter, as shown in Figure 7 reduces noise induced clock jitter and its effects on timing relationships in system designs. The node connecting V_{CCPLL} and the capacitor must be as short as possible. The Figure 7 filter circuit is recommended for each of the Four PLL pairs: $V_{CCPLL1} - V_{SSA1}$, $V_{CCPLL2} - V_{SSA2}$, $V_{CCPLL4} - V_{SSA4}$ and $V_{CCPLL5} - V_{SSA5}$ pairs.

The following notes list the layout guidelines for this filter.

- 4.7 μ H (Inductor)
 - L must be magnetically shielded
 - ESR: max $< 0.4\Omega$
 - rated at 45mA
 - An example of this inductor is TDK part number MLZ2012E4R7P.
- 22 μ F (Capacitor)
 - ESR: max $< 0.4\Omega$
 - ESL < 3.0 nH
 - Place 22 μ F capacitor as close as possible to package pin.
- 0.5 ohm 1% (Resistor)
 - 1/16W 6.3V
- 0.5 ohm 1% resistor must be placed between V_{CC} and L. The resistor rating is 1/16W.
- Route $V_{CCPLL}[1-5]$ and $V_{SSA}[1-5]$ as differential traces.
- $V_{CCPLL}[1-5]$ and $V_{SSA}[1-5]$ traces must be ground referenced (No V_{CC} references).
- Maximum total board trace length = 1.2".
- Minimum trace space to other nets = 30 mils.
- The 1.5 V supply regulator used for the PLL filter must have less than +/- 3% tolerance.
- **Note:** V_{SSA1} , V_{SSA2} , V_{SSA4} and V_{SSA5} pins must **not** be connected to ground.

Figure 7. V_{CCPLL} Configuration

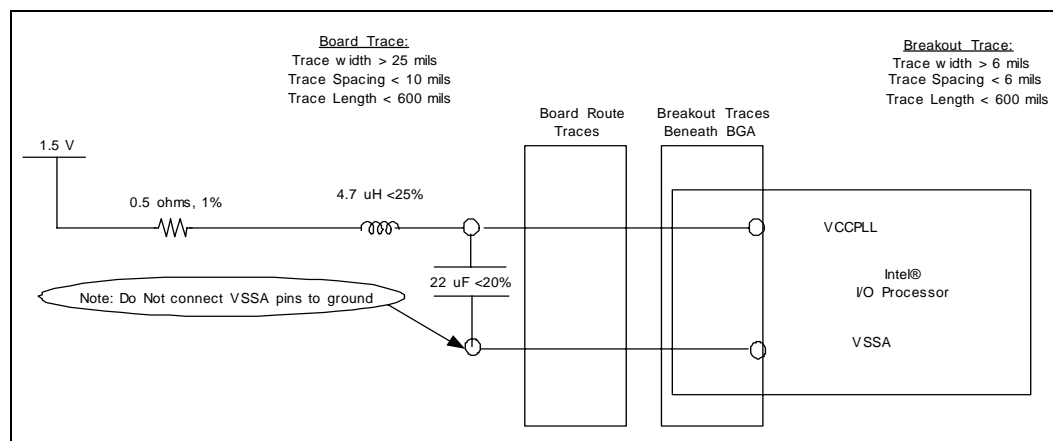

3.2 DDR Resistor Compensation

The Figure 8 provides the 80331 DDR II DDRES circuitry. The DDRRES1 resistor has a tight tolerance of 40.2 ohm 0.5%. DDRRES2 is used as compensation for DDR-II OCD. Due to the fact that OCD is not supported this pin should be pulled to GND with a 1K resistor.

Note: when not in DDR II mode these pins must have a 1.0 K pull-down to GND.

Figure 8. Intel® 80331 I/O Processor DDRRES Resistor Compensation Circuitry

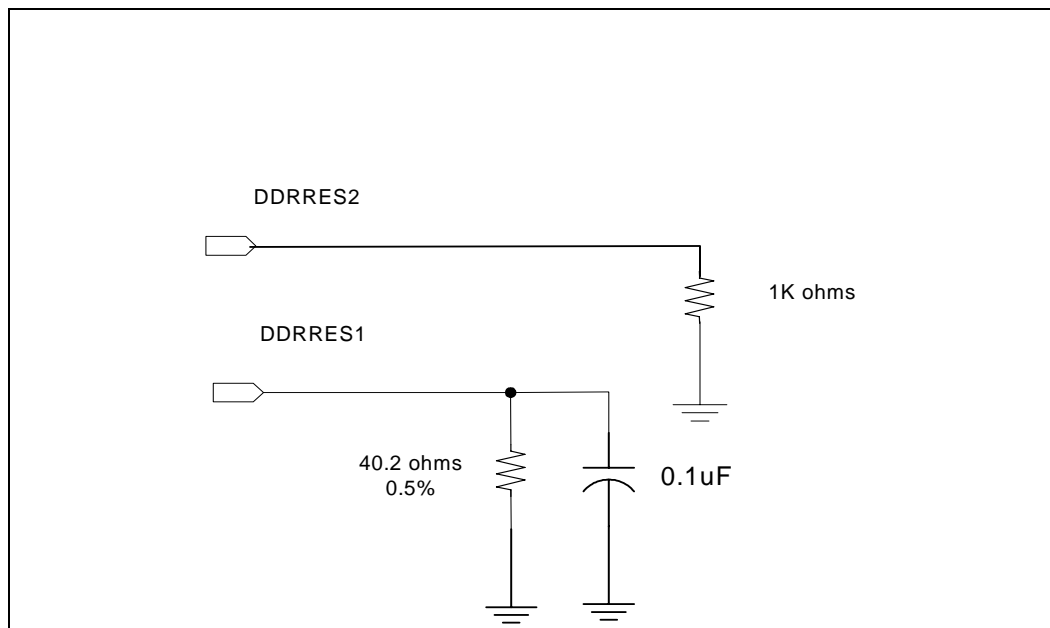

3.3 DDR Driver Compensation

External reference resistors are used to control slew rate and driver impedance. The DDRIMPCRES (or DDRDRVCRES) resistor directly controls the on-die termination (ODT). The recommendations are as follows:

- DDRIMPCRES: controls on-die termination, DDR - 385 ohms, DDRII - 285 ohms. Note that the closest standard 1% resistors are acceptable.
- DDRSLWCRES: controls slew rate and driver impedance, DDR 845 ohms, DDRII 825 ohms.

With these values the ODT is 150/75 ohms for DDRII and 200/100 ohms for DDR.

Figure 9. DDR Driver Compensation Circuitry

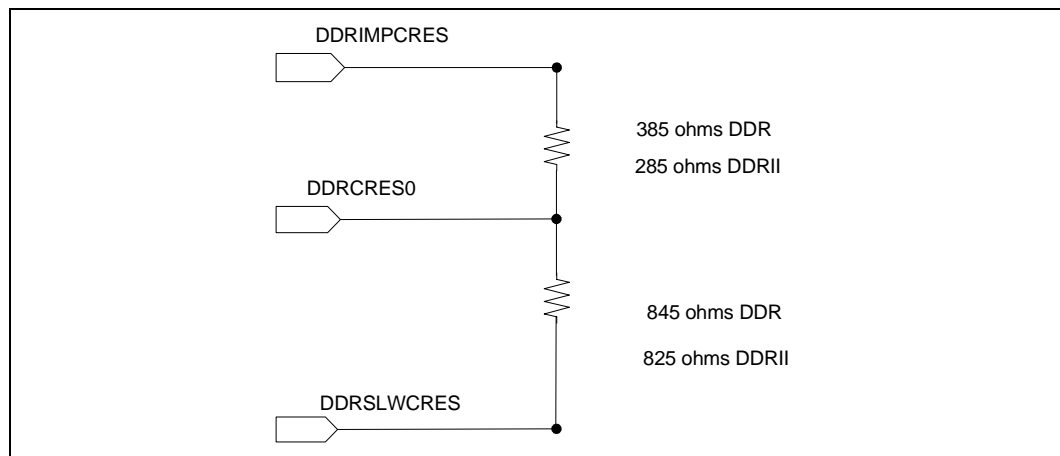

This Page Intentionally Left Blank

Routing Guidelines

4

This chapter provides some basic routing guidelines for layout and design of a printed circuit board using 80331. The high-speed clocking required when designing with the 80331 requires special attention to signal integrity. In fact, it is highly recommended that the board design be simulated to determine optimum layout for signal integrity. The information in this chapter provides guidelines to aid the designer with board layout. Several factors influence the signal integrity of a 80331 design. These factors include:

- Power distribution
- Minimizing crosstalk
- Decoupling
- Layout considerations when routing the DDR memory, DDR II memory, and PCI-X bus interfaces

4.1 General Routing Guidelines

This section details general routing guidelines for designing with 80331. The order in which signals are routed varies from designer to designer. Some designers prefer to route all clock signals first, while others prefer to route all high-speed bus signals first. Either order can be used, provided the guidelines listed here are followed.

4.2 Crosstalk

Crosstalk is caused by capacitive and inductive coupling between signals. Crosstalk is composed of both backward and forward crosstalk components. Backward crosstalk creates an induced signal on victim network that propagates in the opposite direction of the aggressor signal. Forward crosstalk creates a signal that propagates in the same direction as the aggressor signal.

Circuit board analysis software is used to analyze your board layout for crosstalk problems. Examples of 2D analysis tools include Parasitic Parameters from ANSOFT* and XFS from Quad Design*. Crosstalk problems occur when circuit etch lines run in parallel. When board analysis software is not available, the layout needs to be designed to maintain at least the minimum recommended spacing for bus interfaces.

- A general guideline to use is, that space distance between adjacent signals be a least 3.3 times the distance from signal trace to the nearest return plane. The coupled noise between adjacent traces decreases by the square of the distance between the adjacent traces.
- It is also recommended to specify the height of the above reference plane when laying out traces and provide this parameter to the PCB manufacturer. By moving traces closer to the nearest reference plane, the coupled noise decreases by the square of the distance to the reference plane.

Figure 10. Crosstalk Effects on Trace Distance and Height

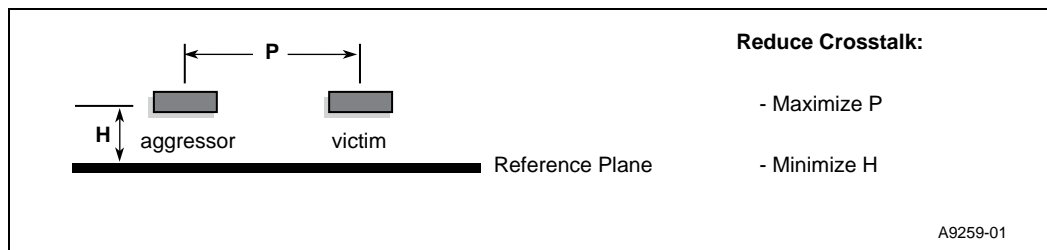

- Avoid slots in the ground plane. Slots increases mutual inductance thus increasing crosstalk.
- Throughout the design guide unbroken GND reference planes are recommended. If it is not possible to route over an unbroken ground plane then an unbroken power plane is acceptable. If it is necessary to use power plane referencing, it is better to reference the power plane used by the I/O connector (if applicable). It is also recommended to add decoupling to the connector near the pins.
- Make sure that ground plane surrounding connector pin fields are not completely cleared out. When this area is completely cleared out, around the connector pins, all the return current must flow together around the pin field increasing crosstalk. The preferred method of laying out a connector in the GND layer is shown in Figure 11B.

Figure 11. PCB Ground Layout Around Connectors

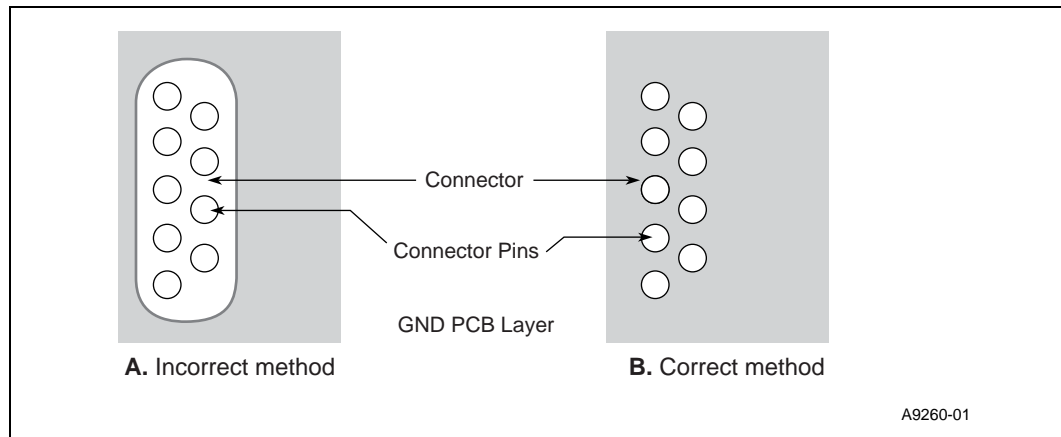

4.3 EMI Considerations

It is highly recommended that good EMI design practices be followed when designing with the 80331.

- To minimize EMI on your PCB a useful technique is to not extend the power planes to the edge of the board.
- Another technique is to surround the perimeter of your PCB layers with a GND trace. This helps to shield the PCB with grounds minimizing radiation.

The below link can provide some useful general EMI guidelines considerations:

<http://developer.intel.com/design/auto/mcs96/applnots/272673.htm>

4.4 Power Distribution and Decoupling

Have ample decoupling to ground, for the power planes, to minimize the effects of the switching currents. Three types of decoupling are: the bulk, the high-frequency ceramic, and the inter-plane capacitors.

- Bulk capacitance consist of electrolytic or tantalum capacitors. These capacitors supply large reservoirs of charge, but they are useful only at lower frequencies due to lead inductance effects. The bulk capacitors can be located anywhere on the board.
- For fast switching currents, high-frequency low-inductance capacitors are most effective. Place these capacitors as close to the device being decoupled as possible. This minimizes the parasitic resistance and inductance associated with board traces and vias.
- Use an inter-plane capacitor between power and ground planes to reduce the effective plane impedance at high frequencies. The general guideline for placing capacitors is to place high-frequency ceramic capacitors as close as possible to the module.

4.4.1 Decoupling

Inadequate high-frequency decoupling results in intermittent and unreliable behavior.

A general guideline recommends that you use the largest easily available capacitor in the lowest inductance package. The high speed decoupling capacitor should be placed as close to the pin as possible with short, wide trace.

Table 4 provides the details on the recommended decoupling capacitors for each of the voltage planes.

Table 4. Decoupling Recommendations

| Voltage Plane | Voltage | Pins | Package | C (μF) | Number of Caps |
|---------------|----------|----------|---------|--------|----------------|
| PCI/PCI-X | 3.3V | VCC33 | 1210 | 22 | 3 |
| PCI/PCI-X | 3.3V | VCC33 | 0603 | 0.1 | 12 |
| PCI/PCI-X | 3.3V | VCC33 | 7343 | 150 | 1 |
| DDR/DDRII | 2.5/1.8V | VCC25/18 | 0603 | 0.1 | 14 |

Table 4. Decoupling Recommendations

| Voltage Plane | Voltage | Pins | Package | C (μF) | Number of Caps |
|---------------|----------|----------|---------|--------|----------------|
| DDR/DDR2 | 2.5/1.8V | VCC25/18 | 1210 | 22 | 2 |
| DDR/DDR2 | 2.5/1.8V | VCC25/18 | 7343 | 150 | 1 |
| Core | 1.5V | VCC15 | 0603 | 0.1 | 17 |
| Core | 1.5V | VCC15 | 1210 | 22 | 2 |
| CPU | 1.35V | VCC13 | 0603 | 0.1 | 6 |
| CPU | 1.35V | VCC13 | 1206 | 10 | 1 |
| CPU | 1.35V | VCC13 | 1210 | 22 | 1 |

NOTES:

1. Polymerized organic capacitors recommended for bulk decoupling.
2. X5R, X7R or COG dielectric recommended for ceramic capacitors.

4.5 Trace Impedance

All signal layers require controlled impedance of $50 \Omega \pm 15\%$, microstrip or stripline where appropriate for motherboard applications and $60 \Omega \pm 15\%$, microstrip or stripline, for add-in card applications. Selecting the appropriate board stack-up to minimize impedance variations is very important. When calculating flight times, it is important to consider the minimum and maximum trace impedance based on the switching neighboring traces. Use wider spaces between traces, since this can minimize trace-to-trace coupling, and reduce cross talk.

When a different stack up is used the trace widths must be adjusted appropriately. When wider traces are used, the trace spacing must be adjusted accordingly (linearly).

It is highly recommended that a 2D Field Solver be used to design the high-speed traces. The following Impedance Calculator URL provide approximations for the trace impedance of various topologies. They may be used to generate the starting point for a full 2D Field solver.

<http://emclab.umr.edu/pcbtlc/>

The following website link provides a useful basic guideline for calculating trace parameters:

<http://www.ultracad.com/calc.htm>

Note: Using stripline transmission lines may give better results than microstrip. This is due to the difficulty of precisely controlling the dielectric constant of the solder mask, and the difficulty in limiting the plated thickness of microstrip conductors, which can substantially increase cross-talk.

Board Layout Guidelines

5

This section provides details on the motherboard and adapter card stackup suggestions. It is highly recommended that signal integrity simulations be run to verify each 80331 PCB layout especially when it deviates from the recommendations listed in these design guidelines. The information in this chapter is an example of a stackup for a motherboard and an adapter card which can be used as a reference.

5.1 Motherboard Stack Up Information

When 80331 is used in server and workstation Raid On Mother Board (ROMB) applications the motherboard is implemented on eight layers. The specified impedance range for all board implementations are 50 ohms +/-15%. Adjustments are made for interfaces specified at other impedances. Table 5 defines the typical layer geometries for six or eight layer boards.

The motherboard is supporting other components in addition to 80331, so it is assumed that server/workstation motherboard requirements dominates to assure the processor and memory subsystem can be implemented with typical 50-ohm guidelines. Dimensions and tolerances for the motherboard are per Table 5. Refer to Figure 12 for location of variables in Table 5.

Table 5. Motherboard Stack Up, Stripline and Microstrip (Sheet 1 of 2)

| Variable | Type | Nominal (mils) | Minimum (mils) | Maximum (mils) | Notes |
|-----------------------------|------------|----------------|----------------|----------------|-----------------------------------------------------------------------------------------------------------------------------------------------------------------------------------------------------------------------------------------------------------------------------------------------------------------------------------|
| Solder Mask Thickness (mil) | N/A | 0.8 | 0.6 | 1.0 | The trace height is determined to achieve a nominal 50 ohms. |
| Solder Mask E_r | N/A | 3.65 | 3.65 | 3.65 | |
| Core Thickness (mil) | N/A | 9.8 | 9.6 | 10 | |
| Core E_r | N/A | 4.30 | 3.75 | 4.85 | 2113 material. |
| Plane Thickness (mil) | Power | 2.7 | 2.5 | 2.9 | |
| | Ground | 1.35 | 1.15 | 1.55 | |
| Trace Height (mil) | 1 | 3.5 | 3.3 | 3.7 | |
| | 2 | 3.5 | 3.3 | 3.7 | |
| | 3 | 10.5 | 9.9 | 11.1 | |
| Preg E_r | Microstrip | 4.30 | 3.75 | 4.85 | 2113 material. |
| | Stripline1 | 4.30 | 3.75 | 4.85 | 2113 material. |
| | Stripline2 | 4.66 | 4.19 | 5.13 | 7628 material. Trace height 3 is composed of one piece of 2113 and one piece of 7628. It is assumed that the 7628 material covers the bottom and sides of the layer 3 traces as well as the top and sides of the layer 4 traces. The 2113 material covers the top of the layer three traces and the bottom of the layer 4 traces. |
| Trace Thickness (mil) | Microstrip | 1.75 | 1.2 | 2.3 | |
| | Stripline | 1.4 | 1.2 | 1.6 | |
| Trace Width (mil) | Microstrip | 5.0 | 3.5 | 6.5 | |

Table 5. Motherboard Stack Up, Stripline and Microstrip (Sheet 2 of 2)

| Variable | Type | Nominal (mils) | Minimum (mils) | Maximum (mils) | Notes |
|------------------------|------------|----------------|----------------|----------------|----------------------------------------------------------------------------------------------------------------------------------------------------------------------------------------------------------------------------------------------------------------------------------------------------------------------------------------------------|
| | Stripline | 4.0 | 2.5 | 5.5 | |
| Trace Spacing (mil) | Microstrip | 15.0 | - | - | Each interface sets the trace spacing based on its signal integrity of differential impedance requirements. For the purposes of the building the transmission line models, it is assumed the artwork is very accurate and therefore a constant. Thus, all the variability in the trace spacing is the result of the tolerances of the trace width. |
| | Stripline | 12.0 | - | - | |
| Total Thickness (mil) | FR4 | 62.0 | 56.0 | 68.0 | |
| Trace Velocity (ps/in) | Microstrip | - | 135 | 141 | Velocity varies based on variation in Er. It cannot be controlled during the fab process. |
| | Stripline | | 167 | 178 | |
| Trace Impedance (ohms) | Microstrip | 50 | 42.5 | 57.5 | |
| | Stripline | 50 | 45 | 55 | |

NOTE: Each interface sets the trace spacing based on its signal integrity of differential impedance requirements. For the purposes of the building the transmission line models, it is assumed the artwork is very accurate and therefore a constant. Thus, all the variability in the trace spacing is the result of the tolerances of the trace width.

Figure 12. Motherboard Stackup Recommendations

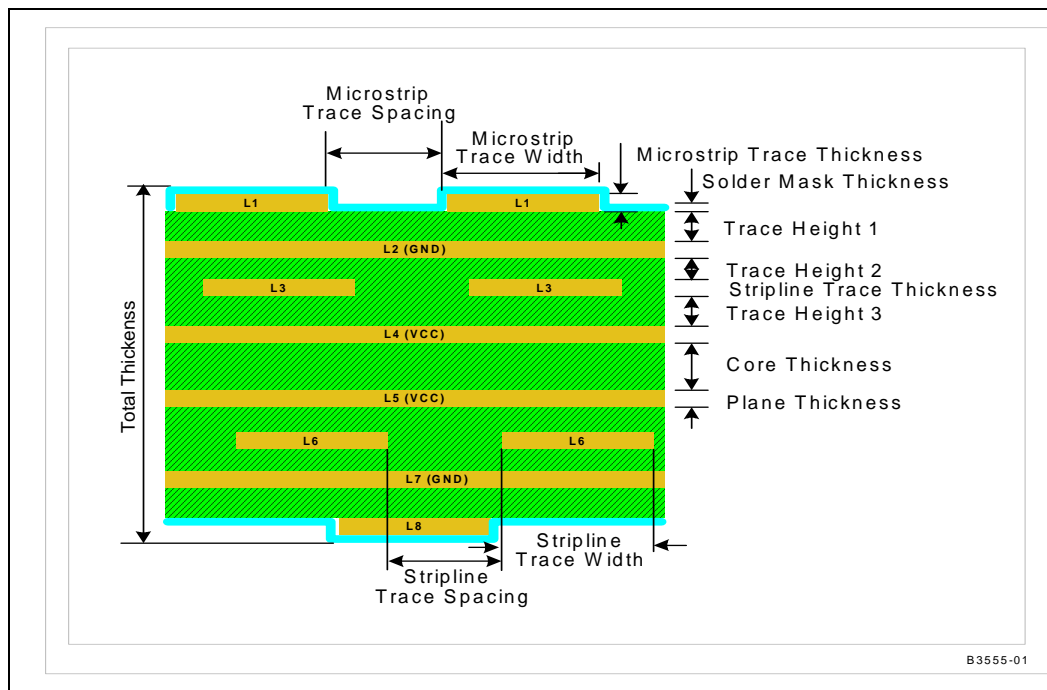

5.2 Adapter Card Stackup

The 80331 can be implemented on PCI-X adapter cards with six or eight layer stackups. The specified impedance range for all adapter card implementations are 60ohms +/-15%. Adjustments are made for interfaces specified at other impedances. Table 6 defines the typical layer geometries for six or eight layer boards.

Note: Values are the same as the motherboard stack up with the exception of the impedance.

Table 6. Adapter Card Stack Up, Microstrip and Stripline

| Variable | Type | Nominal (mils) | Minimum (mils) | Maximum (mils) | Notes |
|------------------------------------------|------------|----------------|----------------|----------------|---------------------------------------------------------------------------------------|
| Solder Mask Thickness (mil) | N/A | 0.8 | 0.6 | 1.0 | |
| Solder Mask E_r | N/A | 3.65 | 3.65 | 3.65 | |
| Core Thickness (mil) | N/A | 2.8 | 3.0 | 3.2 | |
| Core E_r | N/A | 4.3 | 3.75 | 4.85 | 2113 material |
| Plane Thickness (mil) | Power | 2.7 | 2.5 | 2.9 | |
| | Ground | 1.35 | 1.15 | 1.55 | |
| Trace Height (mil) | 1 | 3.5 | 3.3 | 3.7 | The trace height is determined to achieve a nominal 60 ohms. |
| | 2 | 3.5 | 3.3 | 3.7 | |
| | 3 | 10.5 | 9.9 | 11.1 | |
| Preg E_r | Microstrip | 4.30 | 3.75 | 4.85 | 2113 material |
| | Stripline1 | 4.30 | 3.75 | 4.85 | 2113 material |
| | Stripline2 | 4.3 | 3.75 | 4.85 | 7628 material. Trace height 3 is composed of one piece of 2113 and one piece of 7628. |
| Trace Thickness (mil) | Microstrip | 1.75 | 1.2 | 2.3 | |
| | Stripline | 1.4 | 1.2 | 1.6 | |
| Trace Width (mil) | Microstrip | 4.0 | 2.5 | 5.5 | |
| | Stripline | 4.0 | 2.5 | 5.5 | |
| Total Thickness (mil) | FR4 | 62.0 | 56.0 | 68.0 | |
| Trace Spacing (using microstrip E2E/C2C) | [12]/[16] | | | | |
| Trace Spacing (using stripline E2E/C2C) | [12]/[16] | | | | |
| Trace Impedance | Microstrip | 60 | 51 | 69 | |
| | Stripline | 60 | 51 | 69 | |

NOTE: Each interface sets the trace spacing based on its signal integrity of differential impedance requirements. For the purposes of the building the transmission line models, it is assumed the artwork is very accurate and therefore a constant. Thus, all the variability in the trace spacing is the result of the tolerances of the trace width.

Figure 13. Adapter Card Stackup

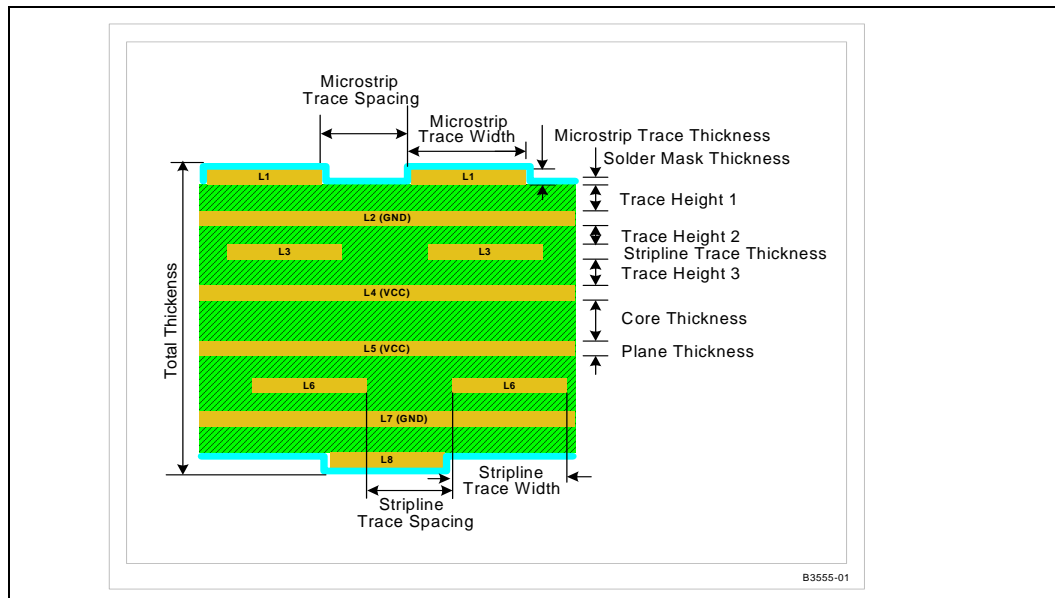

PCI-X Layout Guidelines

6

This chapter describes several factors to be considered with a PCI/PCI-X design. These include the PCI IDSEL, PCI RCOMP, PCI Interrupts, and PCI arbitration.

6.1 Interrupt Routing and IDSEL Lines

Figure 14 shows the 80331 connected to three PCI connectors. Notice that the interrupts are rotated for each connector. The practice of Rotating INTs can also be used when connecting to individual multifunction PCI devices as well. The IDSEL lines acts as chip selects during the configuration cycles. Configuration cycles allow read and write access to one of the device configuration space registers. The IDSEL lines can be mapped to upper address lines which are unused during the configuration cycles. The ATU is hardwired to AD30 for IDSEL. Note that AD16 typically is reserved for a PCI/PCI-X bridge. Each IDSEL line needs a 200 ohm series resistor on it as shown in the figure below.

Figure 14. Interrupt and IDSEL Mapping

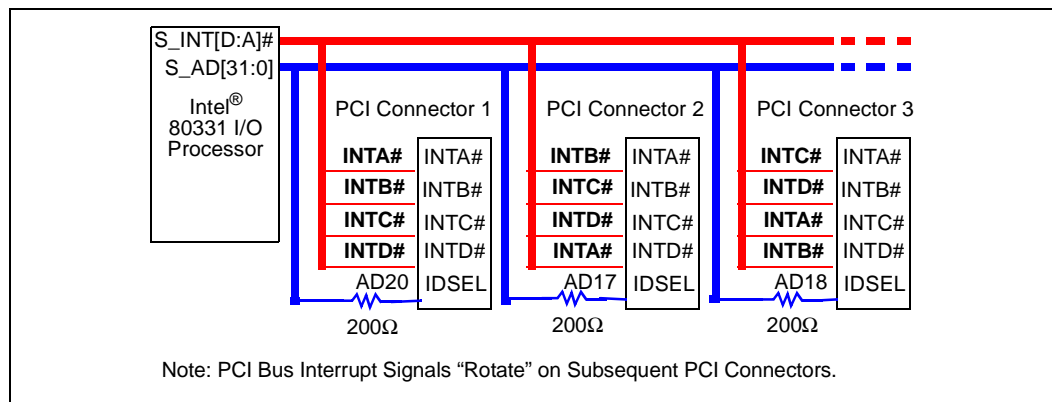

6.1.1 PCI Arbitration

80331 contains two PCI Arbiters to facilitate arbitration on the primary and secondary PCI buses. Refer to the *PCI Local Bus Specification*, Revision 2.3, for more information on arbiter algorithms. The specification essentially states that the algorithm needs to be fair to prevent any one device from consuming too much of the PCI bandwidth.

A typical implementation of the arbitration logic is a two-level rotating round robin configuration. A high priority status is assigned to a master request in level one and a low-level priority status is assigned to a master request in level two. The arbiter checks each of the REQ# lines in the first level. When none are asserted it traverses to checking level two. Once the GNT# has been asserted to a master, this master has the lowest priority in its level.

The arbiter also conducts bus parking by driving A/D, C/BE# and PAR lines to a known value while the bus is idle. The arbiter typically leaves the GNT# asserted to the master that used the bus last.

6.1.2 PCI Resistor Compensation

Figure 15 provides the recommended resistor compensation pin termination for the PCI primary and secondary buses. The voltage at the RCOMP pins is 0.75 V and a 1/16 W resistor rating is acceptable.

Figure 15. PCI RCOMP

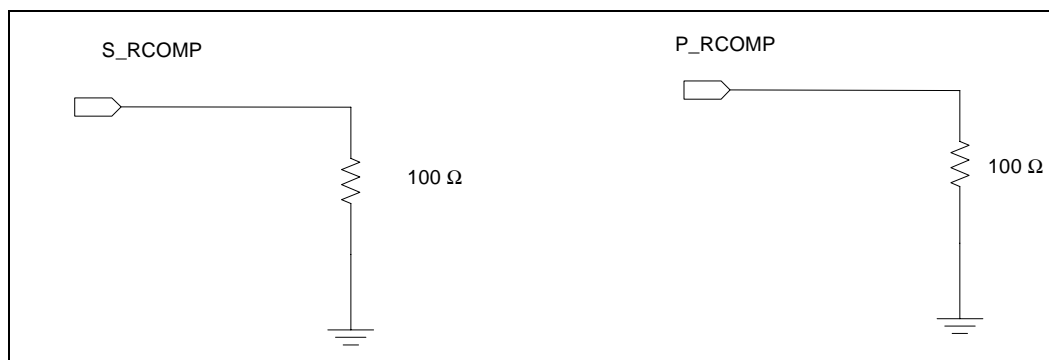

6.2 PCI General Layout Guidelines

For acceptable signal integrity with bus speeds up to 133 MHz it is important to PCB design layout to have controlled impedance.

- Signal trace velocity needs to be roughly 150 – 190 ps/inch
- The following signals have no length restrictions: P_INT[D:A], S_INT[D:A] and **TCK**, **TDI**, **TDO**, **TMS** and **TRST#**

6.3 PCI-X Topology Layout Guidelines

The *PCI-X Addendum to the PCI Local Bus Specification*, Revision 1.0a, recommends the following guidelines for the number of loads for your PCI-X designs. Any deviation from these maximum values requires close attention to layout with regard to loading and trace lengths.

Table 7. PCI-X Slot Guidelines

| Frequency | Maximum Loads | Maximum Number of Slots |
|-----------|---------------|-------------------------|
| 66 MHz | 8 | 4 |
| 100 MHz | 4 | 2 |
| 133 MHz | 2 | 1 |

6.4 Intel® 80331 I/O Processor PCI/X Layout Analysis

The following sections describe layout recommendations based on the signal integrity simulation analysis. This analysis was conducted using the following parameters:

- System board stack up: 50 ohm +/- 15% single-ended impedance
- Add-in card stack up: 60 ohm +/- 15% single-ended impedance
- Driver Model 80331 IBIS
- Receiver Model: generic models for PCI-X and PCI
- Driver Package Model: 80331 model
- Connector Model: Multiline coupled model
- Generic Spec Models: PCI-X and PCI
- Cross talk impact on timing was modeled
- Process corners for PCB stack and trace geometries were modeled
- PVT corner cases for buffers and package models were modeled
- Signal quality analysis covered rise time at the receiver, fall time at the receiver, rising flight time, falling flight time, low to high ring-back (noise margin high), high to low ringback (noise margin low) and low and high overshoot.

Note: The overshoot and undershoot exceeded the specifications. The requirement calls for 0.5 V and the observed overshoot in simulation was 1.2 V. This fact needs to be taken into consideration when accessing the reliability of your application.

The following notes should be considered when designing to this section's design guide recommendations:

1. The lengths recommended for AD lines are given as a range of length (for example 2.0" to 5.0"). This means that each AD bit can be routed anywhere between this range. There is no length matching required among AD bits. For example, AD1 can be 2.0" and AD2 can be 5.0". Routing anywhere in this range assures that the bit will meet the Set up and Hold time requirement. This is because each bit is sampled with respect to a common clock, independent of its relation with other bits.
2. There is **no** length matching requirement between Clock and AD bits. This means, that the clock can be routed to 6" and any AD bit can be 2". However the length matching requirement among clocks to each devices (and feedback clock) remains.
3. If your board aligns to the topology in these recommendations with the exception of one or more devices, these requirements listed are still valid. Each of the recommendations is made with an assumption that any device can be a "no mount". In this case adding the length before and after the "no mount" device, as a single segment is acceptable.

6.4.1 PCI Clock Layout Guidelines

The *PCI-X Addendum to the PCI Local Bus Specification*, Revision 1.0a, allows a maximum of 0.5 ns clock skew timing for each of the PCI-X frequencies: 66 MHz, 100 MHz and 133 MHz. A typical PCI-X application may require separate clock point-to-point connections distributed to each PCI device. 80331 provides four buffered clocks on the secondary PCI bus, S_CLKO[3:0] to connect to multiple PCI-X devices. The Figure 16 shows the use of four secondary PCI clock outputs and length matching requirements. The recommended clock buffer layout are specified as follows:

- Match each of the 80331 output clock lengths to within 25 mils to help minimize the skew.
- Keep distance between clock lines and other signals “d” at least 25 mils from each other.
- Keep distance between clock line and itself “a” at a minimum of 25 mils apart (for serpentine clock layout).
- S_CLKIN gets connected to S_CLKOUT through a 22 ohm resistor
- The 22 ohm resistor is placed within 1” maximum distance of S_CLKOUT.
- A series termination resistor with the value of 22 ohm resistor is placed within 1” maximum distance of each of the clock outputs SCLKO[3:0].

Note: Using the value of 33.2 ohm for the series termination resistor is also acceptable.

Figure 16. PCI Clock Distribution and Matching Requirements

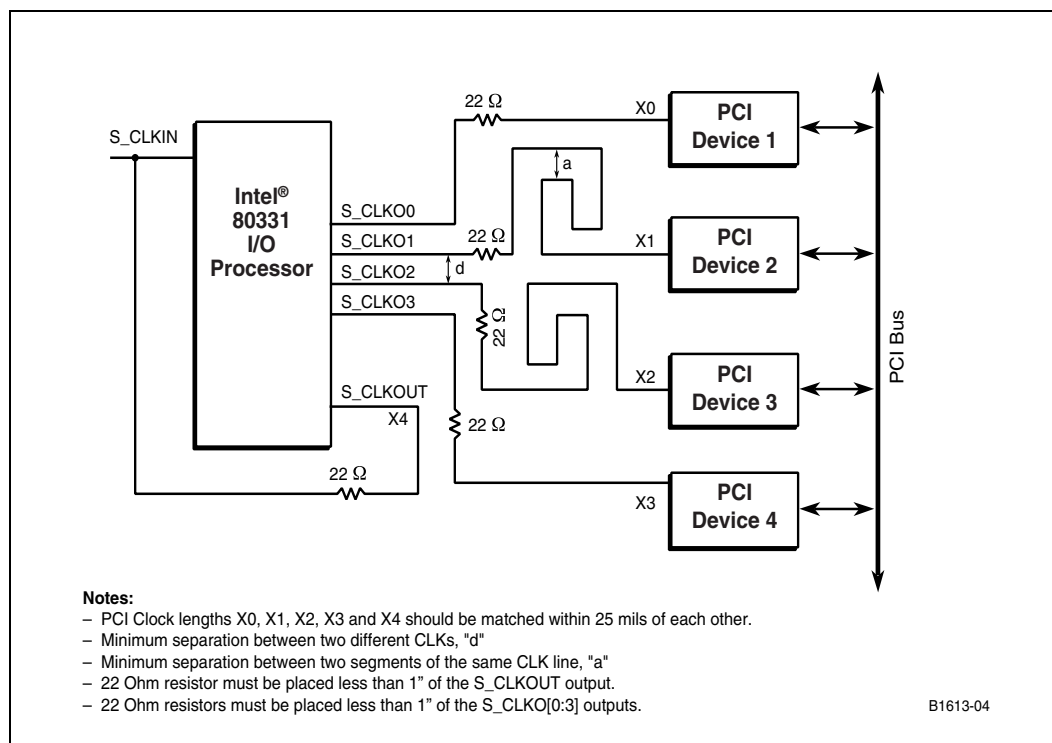

Table 8. PCI-X Clock Layout Requirements Summary (Sheet 1 of 2)

| Parameter | Routing Guidelines |
|------------------------------------------------------------------------------------------------------------------------|--------------------------------------------------------------------------------------------------------------------------------------------------------------------------------------------------------------------------------------------------------------------------------------------------------------------------------------------------------------------------------------------------------------------------------------------------------------------------------------------------------------------------------------------------------|
| Signal Group | PCI Clock S_CLKO[3:0]. |
| Reference Plane | Route over unbroken ground plane. |
| Preferred Topology | Stripline |
| Breakout | 5 mils on 5 mils spacing. Maximum length of breakout region is 500mils. |
| Motherboard Impedance (for both microstrip and stripline). | 50 ohms +/- 15%. |
| Add-in card Impedance (for both microstrip and stripline). | 57 ohms +/- 15%. |
| Stripline Trace Spacing: Separation between two different clock lines, "d" clock lines. | 25 mils edge to edge from any other signal. |
| Stripline Trace Spacing: Separation between two segments of the same clock line (on serpentine layout), "a" dimension. | 25 mils edge to edge from any other signal. |
| Stripline Trace Spacing: Separation between clocks and other lines. | 50 mils edge to edge from any other signal. |
| Length Matching Requirements for Topologies having NO Slot | <ul style="list-style-type: none"> Each of the Clock out (Clk0 - Clk3) should be length matched to the Feedback Clk (Feedback Clock is that running from CLKOUT to CLKIN). The length matching should be within 25 mils. |
| Length Matching Requirements for Topologies having only Slot | <ul style="list-style-type: none"> Each of the Clock out (Clk0 - Clk3) to the Slots should be length matched to within 25mils. The Feedback Clk (Feedback Clock is that running from CLKOUT to CLKIN) should be routed 3.5" longer than the Clocks running to the Slots. This should be done to a tolerance of within 25 mils. |
| Length Matching Requirements for Topologies having both Slots and Embedded Devices | <ul style="list-style-type: none"> Each of the Clock out (Clk0 - Clk3) to the Slots (if more than 1 slot) should be length matched to within 25mils. The Clock out to the Embedded Device(s) should be routed 3.5" longer than the Clocks running to the Slots. This should be done to a tolerance of within 25 mils. The Feedback Clk (Feedback Clock is that running from CLKOUT to CLKIN) should be routed 3.5" longer than the Clocks running to the Slots. This should be done to a tolerance of within 25 mils. |
| Total Length of 80331 PCI CLKs on a motherboard (or embedded design). | Less than 14.0" maximum. |
| Total Length of Clock Line in an Add-in Card. | 2.4" minimum to 2.6" maximum. |
| Series Termination. | 22 ohms 1% |
| Trace Length from driver to series termination. | 1" maximum. |
| S_CLKIN Series Termination. | Connect S_CLKIN to one end of a 22 ohm resistor and the other end connected to S_CLKOUT. |
| Maximum skew for PCIX. | 0.3 ns. |

Table 8. PCI-X Clock Layout Requirements Summary (Sheet 2 of 2)

| Parameter | Routing Guidelines |
|-----------------------|------------------------------------------------------------------------------------------------------|
| Maximum skew for PCI. | 1.0 ns. |
| Routing Guideline 1. | Point-to-point signal routing needs to be used to keep reflections low. |
| Routing Guideline 2. | Same number of vias and routing layers as all the other clock lines from the driver to the receiver. |

6.4.2 Single-Slot at 133 MHz

Figure 17 shows one of the chipset PCI AD lines connected through TL_AD1 line segments to a single-slot connector CONN1 through TL1 line segment to the 80331.

Figure 17. Single-Slot Point-to-Point Topology

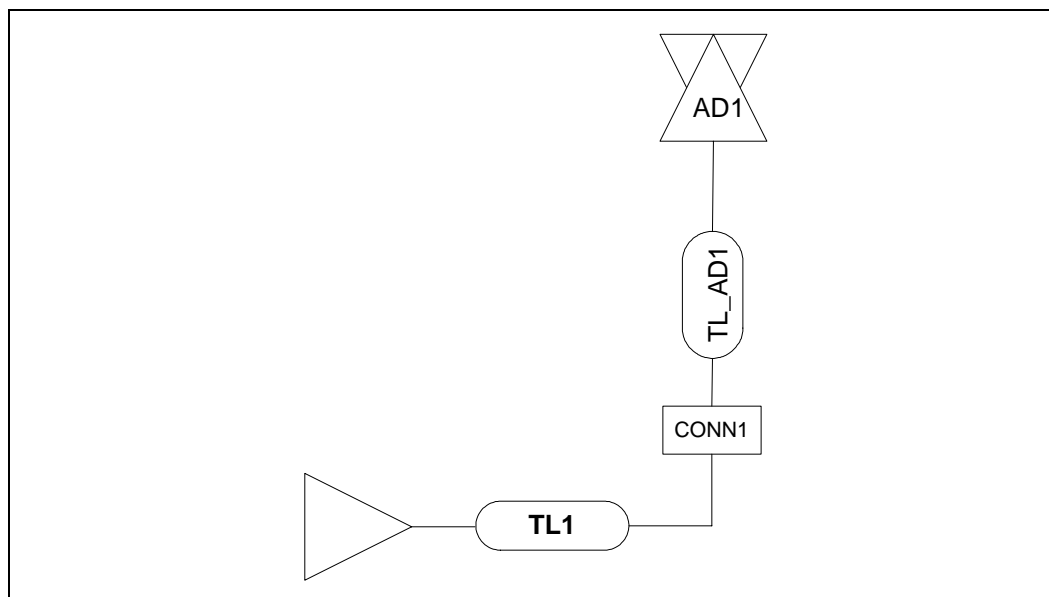

Table 9. PCI-X 133 MHz Single Slot Routing Recommendations

| Parameter | Routing Guideline for Lower AD Bus | Routing Guideline for Upper AD Bus |
|----------------------------------------------------------------|----------------------------------------------------------------------------------------------------------------------------------|------------------------------------|
| Reference Plane Preferred Layer | Route over an unbroken ground plane Stripline | |
| Breakout | 5 mils on 5 mils spacing. Maximum length of breakout region is 500 mils. | |
| Motherboard Impedance (for both microstrip and stripline) | 50 ohms +/- 15% | |
| Add-in card Impedance (for both microstrip and stripline) | 57 ohms +/- 15% | |
| Stripline Trace Spacing | 12 mils from edge to edge | |
| Microstrip Trace Spacing | 18 mils from edge to edge | |
| Group Spacing | Spacing from other groups: 25 mils minimum edge to edge | |
| Trace Length 1 (TL1): From 80331 signal Ball to first junction | 2.25" minimum - 7.5" maximum | 1.25" minimum - 6.75" maximum |
| Trace Length 2 (TL_AD1)- from connector to receiver | 0.75" minimum - 1.5" maximum | 1.75" minimum - 2.75" maximum |
| Length Matching Requirements: | No length matching is required among datalines. For length matching for clocks, refer clock guidelines Table 8 . | |
| Number of vias | Two vias maximum | |

6.4.3 Embedded PCI-X 133 MHz

This section lists the routing recommendations for PCI-X 133 MHz without a slot. [Figure 18](#) shows the block diagram of this topology and [Table 10](#) describes the routing recommendations.

Figure 18. Embedded PCI-X 133 MHz Topology

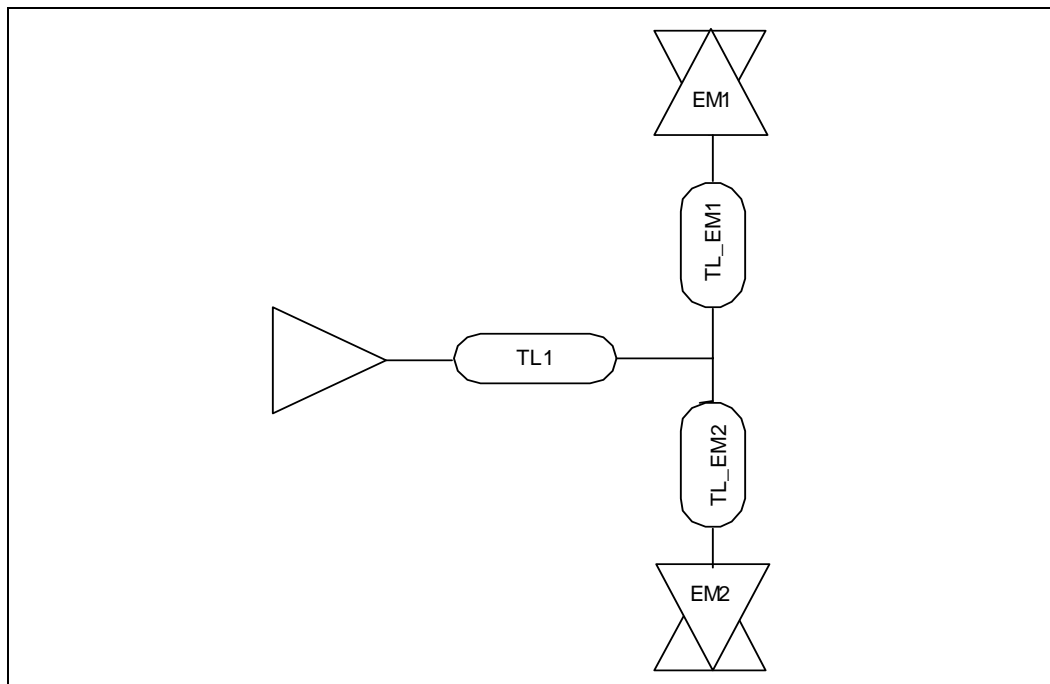

Table 10. Embedded PCI-X 133 MHz Routing Recommendations

| Parameter | Routing Guideline for Lower AD Bus |
|-----------------------------------------------------------------|----------------------------------------------------------------------------------------------------------------------------------|
| Reference Plane Preferred Layer | Route over an unbroken ground plane Stripline |
| Break out | 5 mils on 5 mils spacing. Maximum length of breakout region is 500 mils |
| Motherboard impedance (both Microstrip and stripline) | 50 ohms +/- 15% |
| Add-in card impedance (both Microstrip and stripline) | 60 ohms +/- 15% |
| Stripline Trace Spacing | 12 mils, edge to edge |
| Microstrip Trace Spacing | 18 mils, edge to edge |
| Group Spacing | Spacing from other groups: 25 mils minimum edge-to-edge |
| Trace Length 1 (TL1): From 80331 signal Ball to first junction | 1.75" minimum - 4.0" maximum |
| Trace Length 2 junction of TL_EM1 and TL_EM2 to embedded device | 1.25" minimum - 3.25" maximum |
| Length Matching Requirements: | No length matching is required among datalines. For length matching for clocks, refer clock guidelines Table 8 . |
| Number of vias | Three vias for each path |

6.4.4 Embedded PCI-X 133 MHz Alternate Topology

This section lists another embedded topology with routing recommendations for PCI-X 133 MHz. [Figure 19](#) shows the block diagram of this topology and [Table 11](#) describes the routing recommendations.

Figure 19. Embedded PCI-X 133 MHz Alternate Topology

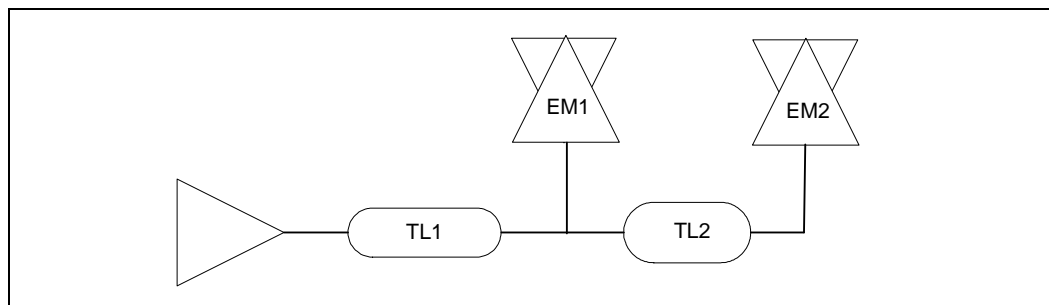

Table 11. Embedded PCI-X 133 MHz Alternate Topology Routing Recommendations

| Parameter | Routing Guideline for Lower AD Bus |
|--------------------------------------------------------------|----------------------------------------------------------------------------------------------------------------------------------|
| Reference Plane Preferred Layer | Route over an unbroken ground plane Stripline |
| Break out | 5 mils on 5 mils spacing. Maximum length of breakout region is 500 mils |
| Motherboard impedance (both Microstrip and stripline) | 50 ohms +/- 15% |
| Add-in card impedance (both Microstrip and stripline) | 60 ohms +/- 15% |
| Stripline Trace Spacing | 12 mils edge to edge |
| Microstrip Trace Spacing | 18 mils, edge to edge |
| Group Spacing | Spacing from other groups: 25 mils minimum edge to edge |
| Trace Length 1 (TL1): From 80331 signal Ball to first device | 1.5" minimum - 3.5" maximum |
| Trace Length 3 TL2: First device to second device. | 1.5" minimum - 3.5" maximum |
| Length Matching Requirements: | No length matching is required among datalines. For length matching for clocks, refer clock guidelines Table 8 . |
| Number of vias | Three vias for each path |

6.4.5 Combination of PCI-X 133 MHz Slot and Embedded Topology

Figure 20 and Table 12 combine the two topologies using both a slot and an embedded device.

Figure 20. Embedded PCI-X 133 MHz Topology

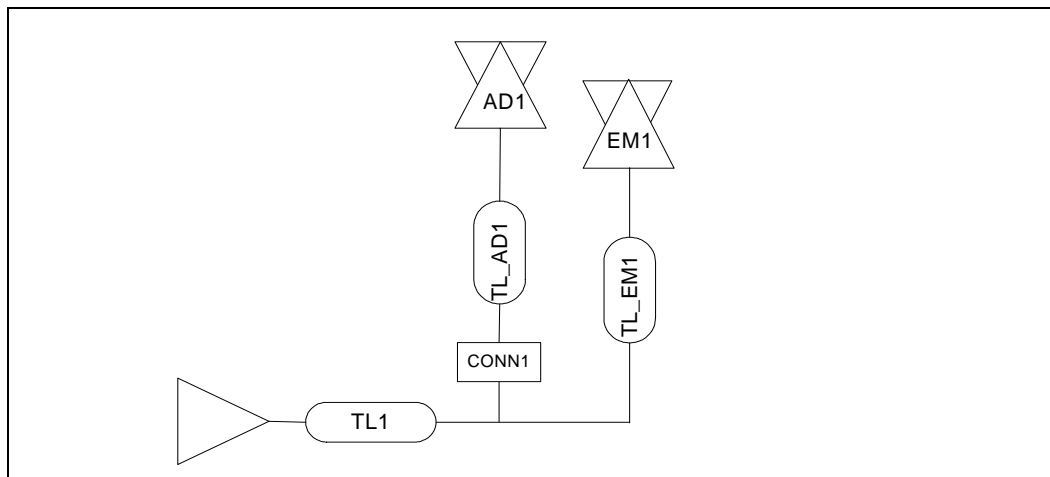

Table 12. Embedded and Slot PCI-X 133 MHz Routing Recommendations

| Parameter | Routing Guideline for Lower AD Bus | Routing Guideline for Upper AD Bus |
|----------------------------------------------------------------------|----------------------------------------------------------------------------------------------------------------------------------|------------------------------------|
| Reference Plane Preferred Layer | Route over an unbroken ground plane Stripline | |
| Break out | 5 mils on 5 mils spacing. Maximum length of breakout region is 500 mils | |
| Motherboard impedance (both Microstrip and stripline) | 50 ohms +/- 15% | |
| Add-in card impedance (both Microstrip and stripline) | 57 ohms +/- 15% | |
| Stripline Trace Spacing | 12 mils edge to edge | |
| Microstrip Trace Spacing | 18 mils, edge to edge | |
| Group Spacing | Spacing from other groups: 25 mils min, center to center | |
| Trace Length 1 (TL1): From 80331 signal ball to first junction | 1.25" minimum - 3.0" maximum | 1.25" minimum - 3.0" maximum |
| Trace Length 3 TL_EM1 from the first junction to the embedded device | 1.25" minimum - 3.75" maximum | 1.25" minimum - 3.75" maximum |
| Trace Length TL_AD1 - from connector to the receiver | 0.75" - 1.5" maximum | 1.75" - 2.75" maximum |
| Length Matching Requirements: | No length matching is required among datalines. For length matching for clocks, refer clock guidelines Table 8 . | |
| Number of vias | Three vias max | |

6.4.6 Combination PCI-X 133 MHz Slot and Embedded Topology 2

Figure 21 and Table 13 combine the two topologies using both a slot and an embedded device.

Figure 21. Embedded PCI-X 133 MHz Topology

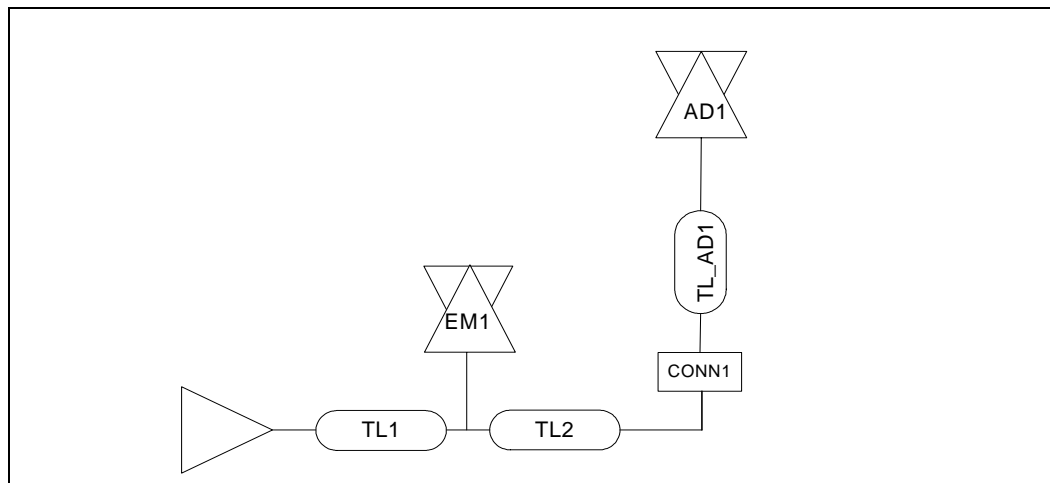

Table 13. Embedded and Slot PCI-X 133 MHz Routing Recommendations

| Parameter | Routing Guideline for Lower AD Bus | Routing Guideline for Upper AD Bus |
|------------------------------------------------------------------|----------------------------------------------------------------------------------------------------------------------------------|------------------------------------|
| Reference Plane Preferred Layer | Route over an unbroken ground plane Stripline | |
| Break out | 5 mils on 5 mils spacing. Maximum length of breakout region is 500 mils | |
| Motherboard impedance (both Microstrip and stripline) | 50 ohms +/- 15% | |
| Add-in card impedance (both Microstrip and stripline) | 57 ohms +/- 15% | |
| Stripline Trace Spacing | 12 mils edge to edge | |
| Microstrip Trace Spacing | 18 mils, edge to edge | |
| Group Spacing | Spacing from other groups: 25 mils min, center to center | |
| Trace Length TL1: From 80331 signal ball to embedded device. | 1.25" minimum - 2.0" maximum | 1.25" minimum - 2.0" maximum |
| Trace Length TL2: - from Embedded Device to PCIX connector CONN1 | 1.25" minimum - 3.5" maximum | 1.25" minimum - 3.0" maximum |
| Trace Length TL_AD1 - from connector to the receiver | 0.75" - 1.5" maximum | 1.75" - 2.75" maximum |
| Length Matching Requirements: | No length matching is required among datalines. For length matching for clocks, refer clock guidelines Table 8 . | |
| Number of vias | Three vias max | |

6.4.7 PCI-X 100 MHz Slot Topology

Figure 22 and Table 14 provide details on the PCI-X 100 MHz slot topology.

Figure 22. Slot PCI-X 100 MHz Slot Routing Topology

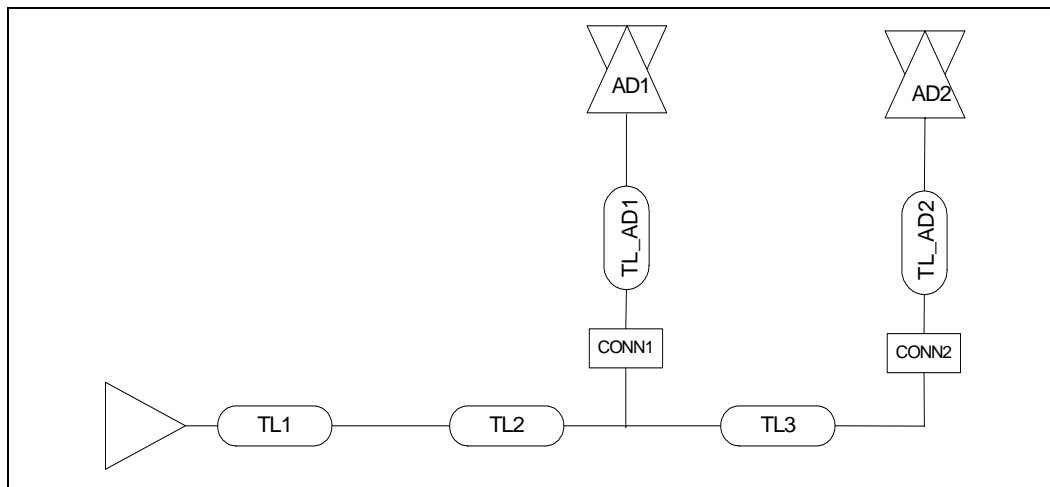

Table 14. PCI-X 100 MHz Slot Topology Routing Recommendations

| Parameter | Routing Guideline for Lower AD Bus | Routing Guideline for Upper AD Bus |
|--------------------------------------------------------------|-----------------------------------------------------------------------------------------------------------------|------------------------------------|
| Reference Plane Preferred Layer | Route over an unbroken ground plane Stripline | |
| Breakout | 5 mils on 5 mils spacing. Maximum length of the breakout is 500 mils. | |
| Motherboard Trace Impedance (microstrip and stripline) | 50 Ohms +/- 15% | |
| Add-in card Impedance (microstrip and stripline) | 57 Ohms +/- 15% | |
| Stripline Trace Spacing | 12 mils, from edge to edge | |
| Microstrip Trace Spacing | 18 mils, from edge to edge | |
| Group Spacing | Spacing from other groups: 25 mils min, center to center | |
| Trace Length 1 TL1: From 80331 signal Ball to first junction | 1.0" minimum - 9.5" maximum | 1.0" - 7.0" maximum |
| Trace Length TL2 - between junction and connector | 0.8" - 1.1" maximum | 0.8" - 1.1" maximum |
| Trace Length TL_AD1, TL_AD2- from connector to receiver | 0.75" minimum - 1.5" maximum | 1.75" minimum - 2.75" maximum |
| Length Matching Requirements: | No length matching is required among datalines. For length matching for clocks, refer clock guidelines Table 8. | |
| Number of vias | Three vias max | |

6.4.8 PCI-X 100 MHz Embedded Topology

Figure 23 and Table 15 combine both a slot and an embedded device.

Figure 23. Embedded PCI-X 100 MHz Routing Topology

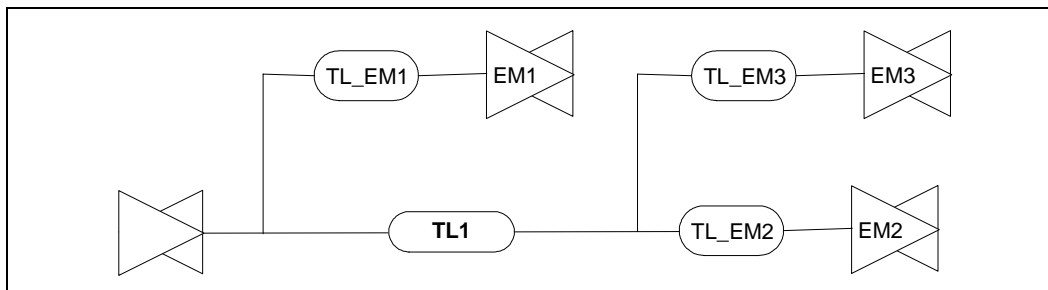

Table 15. PCI-X 100 MHz Embedded Routing Recommendations

| Parameter | Routing Guideline for Lower AD Bus |
|-----------------------------------------------------------------------|----------------------------------------------------------------------------------------------------------------------------------|
| Reference Plane Preferred Layer | Route over an unbroken ground plane Stripline |
| Breakout | 5 mils on 5 mils spacing. Maximum length of the breakout is 500 mils. |
| Motherboard Trace Impedance (microstrip and stripline) | 50 Ohms +/- 15% |
| Add-in card Impedance (microstrip and stripline) | 60 Ohms +/- 15% |
| Stripline Trace Spacing | 12 mils, from edge to edge |
| Microstrip Trace Spacing | 18 mils, from edge to edge |
| Group Spacing | Spacing from other groups: 25 mils minimum edge to edger |
| Trace Length 1 TL1: From 80331 signal Ball to first junction | 0.5" minimum - 3.0" maximum |
| Trace Length TL_EM1 - between junction and embedded device | 2.5" - 3.5" maximum |
| Trace Length TL_EM2, TL_EM3- from second junction to embedded devices | 1.5" minimum to 3.5 maximum |
| Length Matching Requirements: | No length matching is required among datalines. For length matching for clocks, refer clock guidelines Table 8 . |
| Number of vias | Four vias maximum for each path |

6.4.9 PCI-X 100 MHz Slot and Embedded Topology

Figure 24 and Table 16 combine both slots and an embedded device.

Figure 24. Combination of Slot and Embedded PCI-X 100 MHz Routing Topology

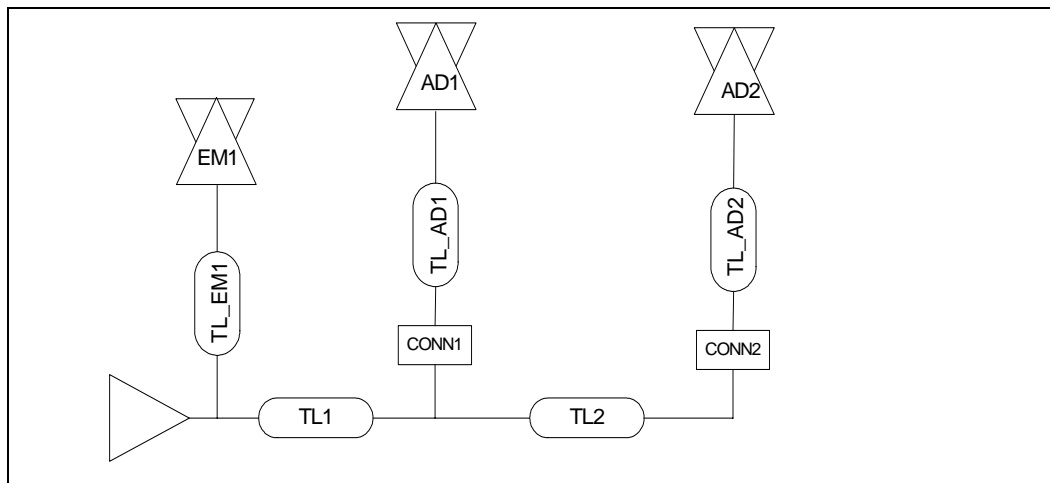

Table 16. Combination of Slot and Embedded PCI-X 100 MHz Routing Recommendations

| Parameter | Routing Guideline for Lower AD Bus | Routing Guideline for Upper AD Bus |
|----------------------------------------------------------------------------|----------------------------------------------------------------------------------------------------------------------------------|------------------------------------|
| Reference Plane Preferred Layer | Route over an unbroken ground plane Stripline | |
| Breakout | 5 mils on 5 mils spacing. Maximum length of the breakout is 500 mils. | |
| Motherboard Trace Impedance (microstrip and stripline) | 50 Ohms +/- 15% | |
| Add-in card Impedance (microstrip and stripline) | 57 Ohms +/- 15% | |
| Stripline Trace Spacing | 12 mils, from edge to edge | |
| Microstrip Trace Spacing | 18 mils, from edge to edge | |
| Group Spacing | Spacing from other groups: 25 mils minimum edge to edge | |
| Trace Length 1 TL1: From 80331 signal Ball to first connector CONN1 | 2.0" minimum - 3.75" maximum | 2.0" minimum - 3.0" maximum |
| Trace Length TL2 - first PCI connector CONN1 to second PCI connector CONN2 | 0.8" minimum - 1.2" maximum | |
| Trace Length TL_AD1, TL_AD2 - from PCI connector to receiver | 2.25" minimum - 3.75" maximum | 2.25" minimum - 3.5" maximum |
| Trace Length TL_EM1 - from second connector CONN2 to embedded device | 0.75" minimum - 1.5" maximum | 1.75" minimum - 2.75" maximum |
| Length Matching Requirements: | No length matching is required among datalines. For length matching for clocks, refer clock guidelines Table 8 . | |
| Number of vias | Three vias maximum | |

6.4.10 PCI-X 100 MHz Slot and Embedded Topology 2

Figure 24 and Table 16 combine both a slot and an embedded device.

Figure 25. Combination of Slots and Embedded PCI-X 100 MHz Routing Topology

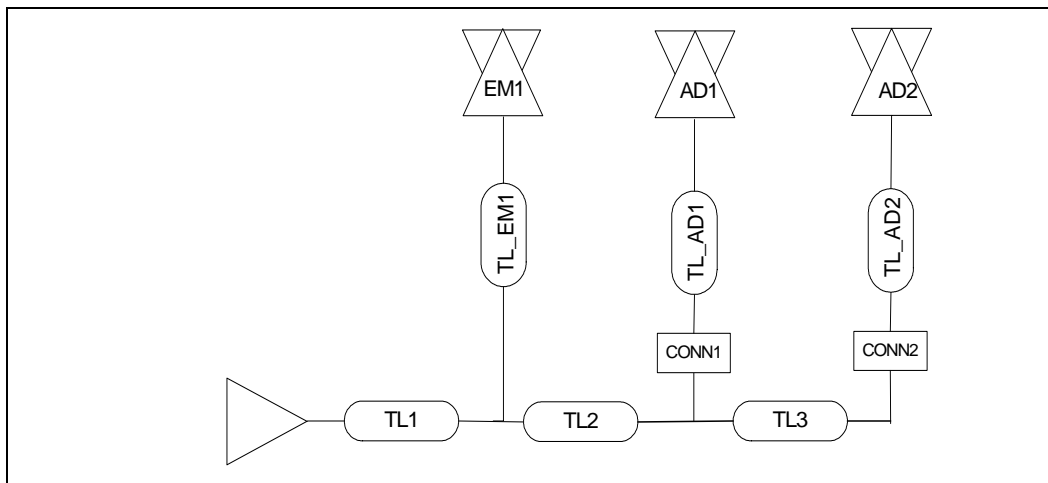

Table 17. Combination of Slot and Embedded PCI-X 100 MHz Routing 2 Recommendations (Sheet 1 of 2)

| Parameter | Routing Guideline for Lower AD Bus | Routing Guideline for Upper AD Bus |
|-------------------------------------------------------------------|-----------------------------------------------------------------------|------------------------------------|
| Reference Plane Preferred Layer | Route over an unbroken ground plane Stripline | |
| Breakout | 5 mils on 5 mils spacing. Maximum length of the breakout is 500 mils. | |
| Motherboard Trace Impedance (microstrip and stripline) | 50 Ohms +/- 15% | |
| Add-in card Impedance (microstrip and stripline) | 57 Ohms +/- 15% | |
| Stripline Trace Spacing | 12 mils, from edge to edge | |
| Microstrip Trace Spacing | 18 mils, from edge to edge | |
| Group Spacing | Spacing from other groups: 25 mils minimum edge to edge | |
| Trace Length 1 TL1: From 80331 signal Ball to first junction | 1.5" minimum - 4.25" maximum | 1.5" minimum - 3.75" maximum |
| Trace Length TL2 - first junction to First PCI Connector | 0.0" minimum to 1.0" maximum | |
| Trace Length TL3 - First PCI Connector to Second PCI Connector | 0.8" minimum - 1.2" maximum | |
| Trace Length TL_EM1 - from first junction to the Embedded Device. | 1.0" minimum - 3.25" maximum | 1.0" minimum - 3.25" maximum |

Table 17. Combination of Slot and Embedded PCI-X 100 MHz Routing 2 Recommendations (Sheet 2 of 2)

| | | |
|----------------------------------------------------------|----------------------------------------------------------------------------------------------------------------------------------|-------------------------------|
| Trace Length TL_AD1, TL_AD2 - from connector to receiver | 0.75" minimum - 1.5" maximum | 1.75" minimum - 2.75" maximum |
| Length Matching Requirements: | No length matching is required among datalines. For length matching for clocks, refer clock guidelines Table 8 . | |
| Number of vias | Three vias maximum | |

6.4.11 PCI-X 66 MHz Slot Topology

Figure 26 and [Table 18](#) provides routing details for a topology with for an embedded PCI-X 66 MHz application.

Figure 26. PCI-X 66 MHz Slot Routing Topology

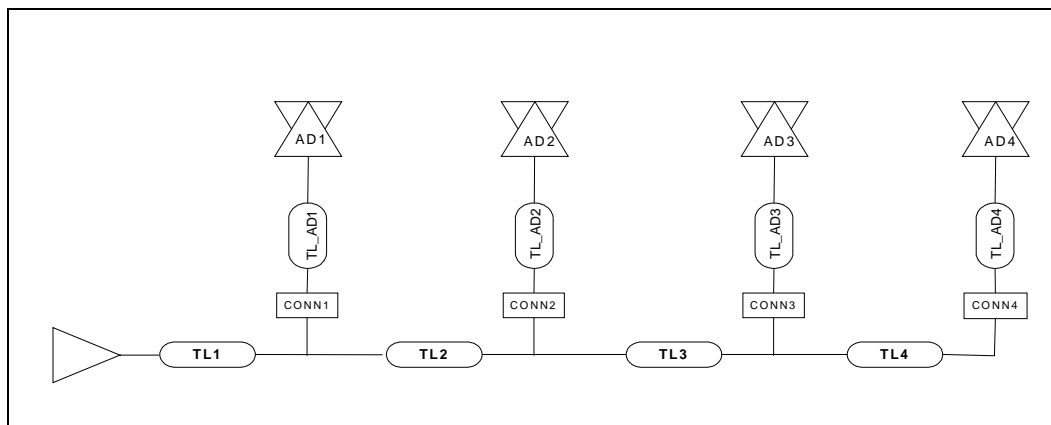

Table 18. PCI-X 66 MHz Slot Routing Recommendations (Sheet 1 of 2)

| Parameter | Routing Guideline for AD Bus | |
|----------------------------------------------------------------|-----------------------------------------------------------------------|------------------------------|
| Reference Plane | Route over an unbroken ground plane | |
| Breakout | 5 mils on 5 mils spacing. Maximum length of the breakout is 500 mils. | |
| Motherboard Trace Impedance (microstrip and stripline) | 50 Ohms +/- 15% | |
| Add-in card Impedance (microstrip and stripline) | 57 Ohms +/- 15% | |
| Stripline Trace Spacing | 12 mils, from edge to edge | |
| Microstrip Trace Spacing | 18 mils, from edge to edge | |
| Group Spacing | Spacing from other groups: 25 mils minimum center to center | |
| Trace Length 1 (TL1): From 80331 signal Ball to first junction | 1.0" minimum - 6.0" maximum | 1.0" minimum - 4.75" maximum |
| Trace Length TL2 to TL4 between junctions | 0.8" minimum - 1.2" maximum | |

Table 18. PCI-X 66 MHz Slot Routing Recommendations (Sheet 2 of 2)

| | | |
|------------------------------------------------------------------------|----------------------------------------------------------------------------------------------------------------------------------|-------------------------------|
| Trace Length TL_AD1 to TL_AD4 - from junction to connector to receiver | 0.75" minimum - 1.5" maximum | 1.75" minimum - 2.75" maximum |
| Length Matching Requirements: | No length matching is required among datalines. For length matching for clocks, refer clock guidelines Table 8 . | |
| Number of vias | Four vias maximum | |

6.4.12 PCI-X 66 MHz Embedded Topology

Figure 27 and Table 19 provides routing details for a topology with for an embedded PCI-X 66 MHz application.

Figure 27. PCI-X 66 MHz Embedded Routing Topology

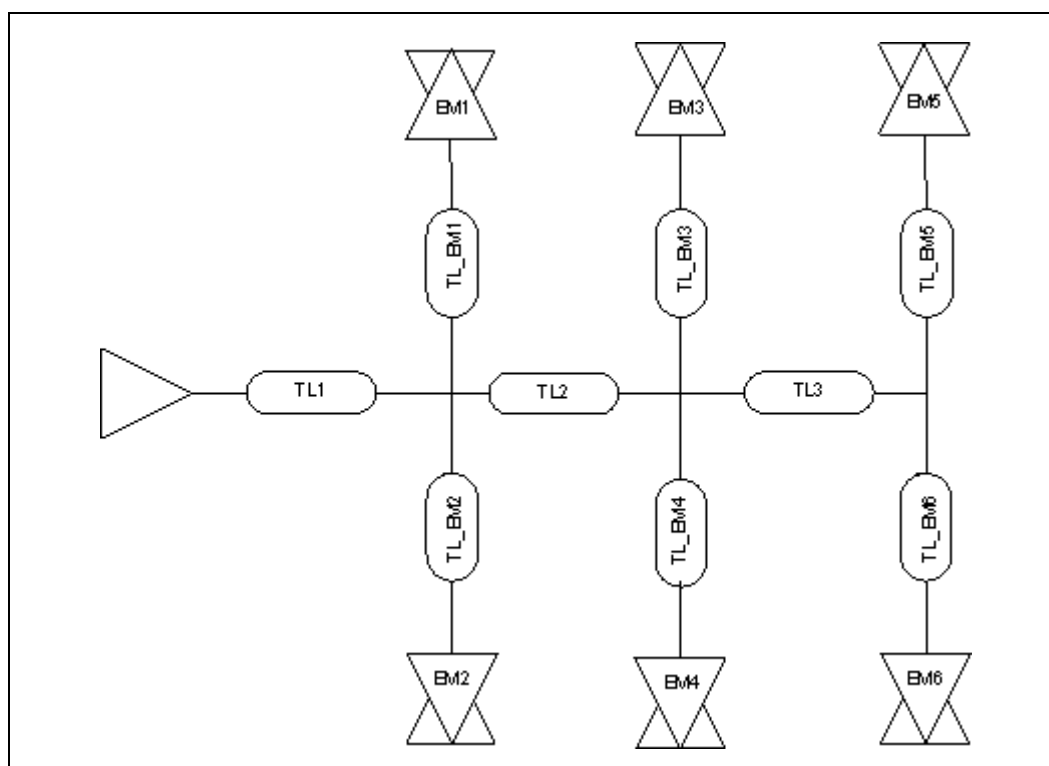

Table 19. PCI-X 66 MHz Embedded Routing Recommendations (Sheet 1 of 2)

| Parameter | Routing Guideline for AD Bus |
|--------------------------------------------------------|-----------------------------------------------------------------------|
| Reference Plane | Route over an unbroken ground plane |
| Breakout | 5 mils on 5 mils spacing. Maximum length of the breakout is 500 mils. |
| Motherboard Trace Impedance (microstrip and stripline) | 50 Ohms +/- 15% |
| Add-in card Impedance (microstrip and stripline) | 60 Ohms +/- 15% |
| Stripline Trace Spacing | 12 mils, from edge to edge |

Table 19. PCI-X 66 MHz Embedded Routing Recommendations (Sheet 2 of 2)

| | |
|-------------------------------------------------------------------|----------------------------------------------------------------------------------------------------------------------------------|
| Microstrip Trace Spacing | 18 mils, from edge to edge |
| Group Spacing | Spacing from other groups: 25 mils minimum center to center |
| Trace Length 1 (TL1): From 80331 signal Ball to first junction | 1.0" minimum - 5.0" maximum |
| Trace Length TL2 to TL3 between junctions | 1.0" minimum - 2.5" maximum |
| Trace Length TL_EM1 to TL_EM6 - from junction to embedded devices | 2.0" minimum - 3.0" maximum |
| Length Matching Requirements: | No length matching is required among datalines. For length matching for clocks, refer clock guidelines Table 8 . |
| Number of vias | Four vias maximum |

6.4.13 PCI-X 66 MHz Mixed Mode Topology

Figure 28 and Table 20 provides routing details for a topology with for an embedded PCI-X 66 MHz design with slots.

Figure 28. PCI-X 66 MHz Mixed Mode Routing Topology

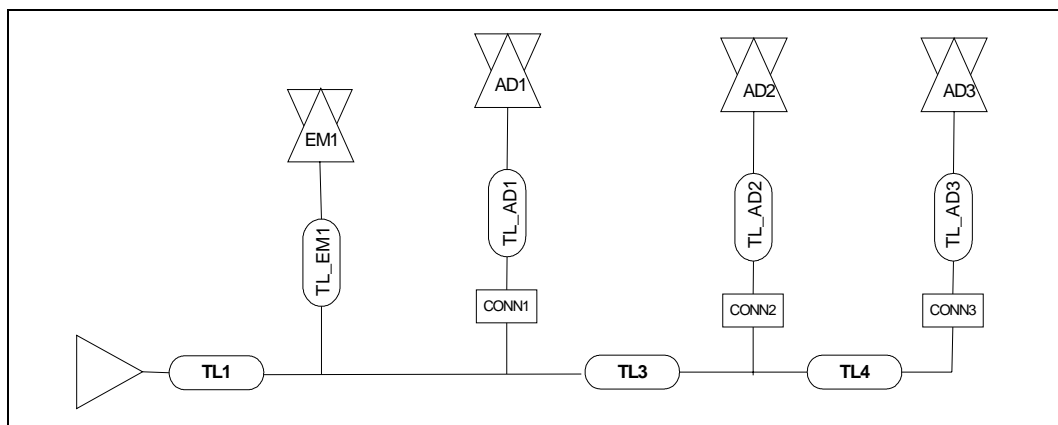

Table 20. PCI-X 66 MHz Mixed Mode Routing Recommendations (Sheet 1 of 2)

| Parameter | Routing Guideline for AD Bus | Routing Guideline for Upper AD Bus |
|----------------------------------------------------------|-----------------------------------------------------------------------|------------------------------------|
| Reference Plane | Route over an unbroken ground plane | |
| Breakout | 5 mils on 5 mils spacing. Maximum length of the breakout is 500 mils. | |
| Motherboard Trace Impedance (microstrip and stripline) | 50 Ohms +/- 15% | |
| Add-in card Impedance (microstrip and stripline) | 57 Ohms +/- 15% | |
| Stripline Trace Spacing | 12 mils, from edge to edge | |
| Microstrip Trace Spacing | 18 mils, from edge to edge | |
| Group Spacing | Spacing from other groups: 25 mils minimum center to center | |
| Trace Length 1 TL1: From 80331 signal Ball to first slot | 1.0" minimum - 5.0" maximum | 1.0" minimum - 4.5" maximum |

Table 20. PCI-X 66 MHz Mixed Mode Routing Recommendations (Sheet 2 of 2)

| | | |
|--------------------------------------------------------------------------|----------------------------------------------------------------------------------------------------------------------------------|-------------------------------|
| Trace Length TL3, TL4, between connectors | 0.8" minimum - 1.4" maximum | |
| Trace Length TL_EM1 from the first PCI connector to the embedded device. | 1.0" minimum - 3.5" maximum | |
| Trace Length TL_AD1, TL_AD2, TL_AD3 from PCI connector to the Receiver | 0.75" minimum - 1.5" maximum | 1.75" minimum - 2.75" maximum |
| Length Matching Requirements: | No length matching is required among datalines. For length matching for clocks, refer clock guidelines Table 8 . | |
| Number of vias | Four vias maximum | |

6.4.14 PCI 66 MHz Slot Topology

Figure 29 and Table 21 provides routing details for a topology with for an PCI 66 MHz design with slots.

Figure 29. PCI 66 MHz Topology

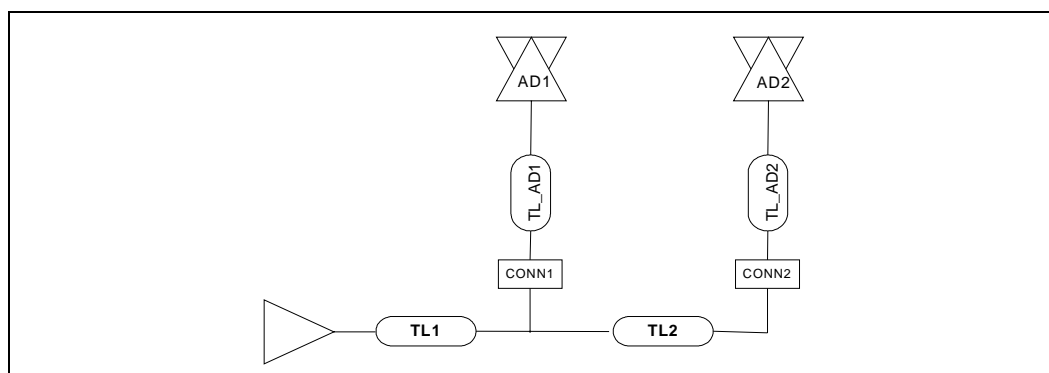

Table 21. PCI 66 MHz Slot Table (Sheet 1 of 2)

| Parameter | Routing Guideline for AD Bus | Routing Guideline for Upper AD Bus |
|---------------------------------------------------------------|-----------------------------------------------------------------------|------------------------------------|
| Reference Plane | Route over an unbroken ground plane | |
| Breakout | 5 mils on 5 mils spacing. Maximum length of the breakout is 500 mils. | |
| Motherboard Trace Impedance (microstrip and stripline) | 50 Ohms +/- 15% | |
| Add-in card Impedance (microstrip and stripline) | 60 Ohms +/- 15% | |
| Stripline Trace Spacing | 10 mils, from edge to edge | |
| Microstrip Trace Spacing | 15 mils, from edge to edge | |
| Group Spacing | Spacing from other groups: 25 mils minimum edge-to-edge | |
| Trace Length 1 TL1: From 80331 signal Ball to first connector | 1.0" minimum - 7.0" maximum | 1.0" minimum - 7.0" maximum |
| Trace Length TL2 between connectors | 0.8" minimum - 1.2" maximum | |

Table 21. PCI 66 MHz Slot Table (Sheet 2 of 2)

| Parameter | Routing Guideline for AD Bus | Routing Guideline for Upper AD Bus |
|--------------------------------------------------------|-----------------------------------------------------------------------------------------------------------------|------------------------------------|
| Trace Length TL_AD1, TL_AD2 from connector to receiver | 0.75" minimum - 1.5" maximum | 1.75" minimum - 2.75" maximum |
| Length Matching Requirements | No length matching is required among datalines. For length matching for clocks, refer clock guidelines Table 8. | |
| Number of Vias | Four vias maximum | |

6.4.15 PCI 66 MHz Embedded Topology

Figure 30 and Table 22 provides routing details for a topology with for an embedded PCI 66 MHz design.

Figure 30. PCI 66 MHz Embedded Topology

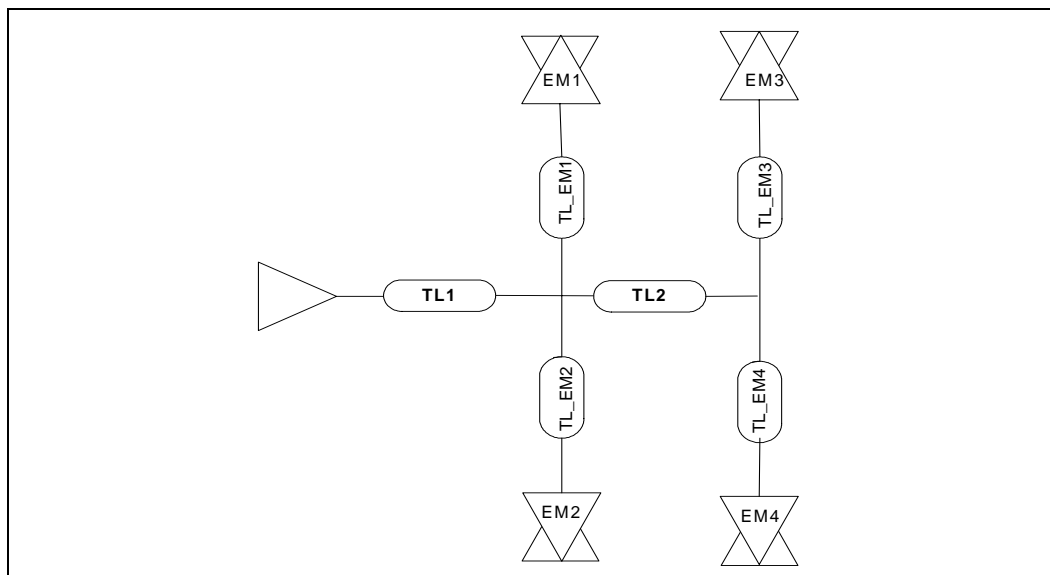

Table 22. PCI 66 MHz Embedded Table (Sheet 1 of 2)

| Parameter | Routing Guideline for AD Bus |
|--------------------------------------------------------|-----------------------------------------------------------------------|
| Reference Plane | Route over an unbroken ground plane |
| Breakout | 5 mils on 5 mils spacing. Maximum length of the breakout is 500 mils. |
| Motherboard Trace Impedance (microstrip and stripline) | 50 Ohms +/- 15% |
| Add-in card Impedance (microstrip and stripline) | 60 Ohms +/- 15% |
| Stripline Trace Spacing | 10 mils, from edge to edge |
| Microstrip Trace Spacing | 15 mils, from edge to edge |
| Group Spacing | Spacing from other groups: 25 mils minimum edge to edge |

Table 22. PCI 66 MHz Embedded Table (Sheet 2 of 2)

| Parameter | Routing Guideline for AD Bus |
|-----------------------------------------------------------------|----------------------------------------------------------------------------------------------------------------------------------|
| Trace Length 1 TL1: From 80331 signal Ball to first junction | 5.0" maximum |
| Trace Length TL2 between junctions | 0.5" minimum - 3.5" maximum |
| Trace Length TL_EM1 to TL_EM4 from junction to embedded devices | 2.0" minimum - 3.0" maximum |
| Length Matching Requirements | No length matching is required among datalines. For length matching for clocks, refer clock guidelines Table 8 . |
| Number of vias | Four vias maximum |

6.4.16 PCI 66 MHz Mixed Mode Topology

Figure 31 and Table 23 provide routing details for a topology with embedded devices and PCI 66 MHz slots.

Figure 31. PCI 66 MHz Mixed Topology

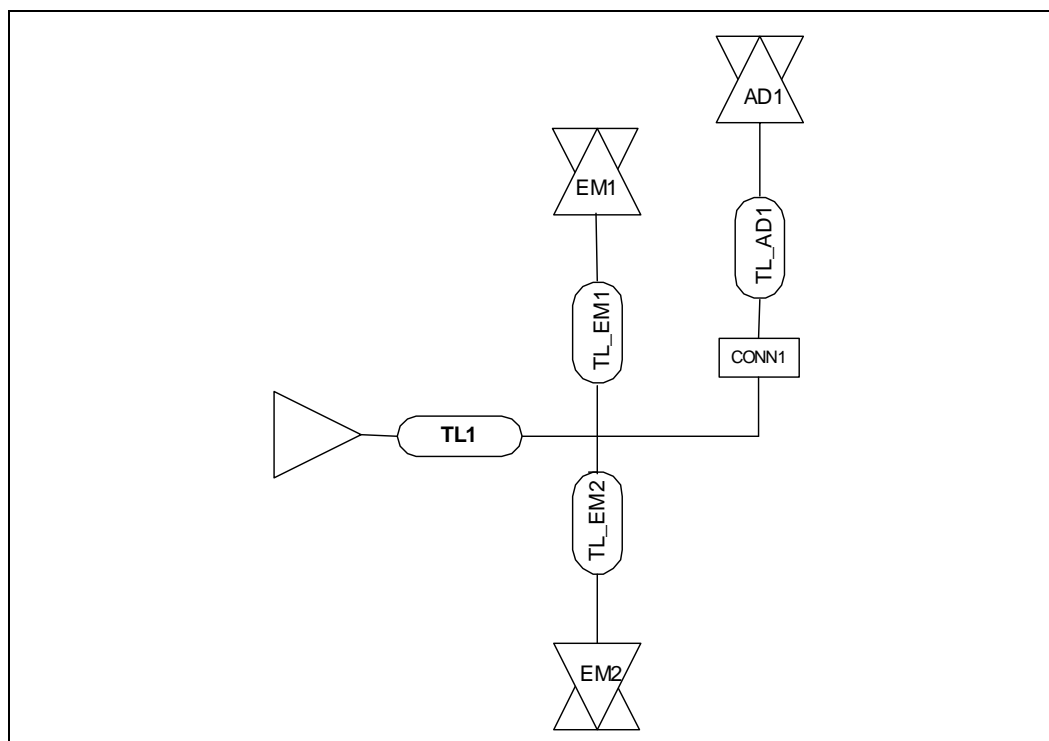

Table 23. PCI 66 MHz Mixed Mode Table (Sheet 1 of 2)

| Parameter | Routing Guideline Lower AD Bus | Routing Guideline Upper AD Bus |
|--------------------------------------------------------|-----------------------------------------------------------------------|--------------------------------|
| Reference Plane | Route over an unbroken ground plane | |
| Breakout | 5 mils on 5 mils spacing. Maximum length of the breakout is 500 mils. | |
| Motherboard Trace Impedance (microstrip and stripline) | 50 Ohms +/- 15% | |

Table 23. PCI 66 MHz Mixed Mode Table (Sheet 2 of 2)

| Parameter | Routing Guideline Lower AD Bus | Routing Guideline Upper AD Bus |
|------------------------------------------------------------------------|----------------------------------------------------------------------------------------------------------------------------------|--------------------------------|
| Add-in card Impedance (microstrip and stripline) | 57 Ohms +/- 15% | |
| Stripline Trace Spacing | 10 mils, from edge to edge | |
| Microstrip Trace Spacing | 15 mils, from edge to edge | |
| Group Spacing | Spacing from other groups: 25 mils minimum edge-to-edge | |
| Trace Length 1 TL1: From 80331 signal Ball to first connector | 1.0" minimum to 5.0" maximum | 1.0" minimum - 4.5" maximum |
| Trace Length TL_EM1, TL_EM2: From 1st PCI connector to embedded device | 1.5" minimum - 4.0" maximum | |
| Trace Length TL_AD1 from PCI connector to receiver | 0.75" minimum - 1.5" maximum | 1.75" minimum - 2.75" maximum |
| Length Matching Requirements | No length matching is required among datalines. For length matching for clocks, refer clock guidelines Table 8 . | |
| Number of Vias | Four vias maximum | |

6.4.17 PCI 33 MHz Slot Topology

Figure 32 and Table 24 provides routing details for a topology with for a PCI 33 MHz design with slots.

Figure 32. PCI 33 MHz Slot Routing Topology

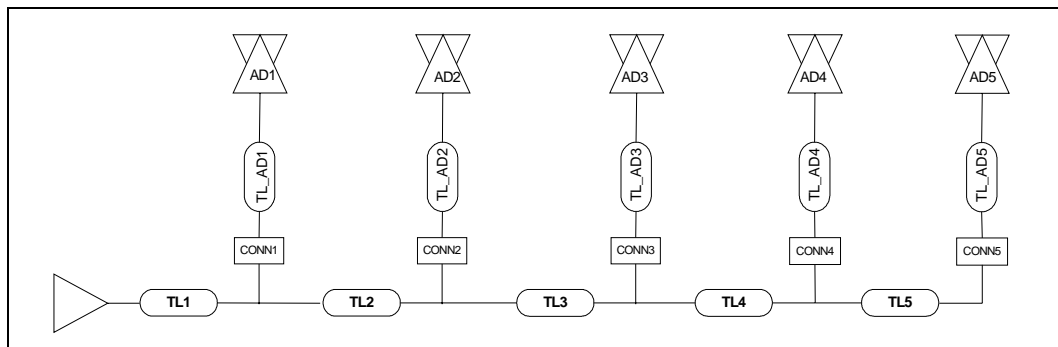

Table 24. PCI 33 MHz Slot Routing Recommendations (Sheet 1 of 2)

| Parameter | Routing Guideline for AD Bus | |
|---------------------------------------------------------------|-----------------------------------------------------------------------|---------------------------|
| Reference Plane | Route over an unbroken ground plane | |
| Breakout | 5 mils on 5 mils spacing. Maximum length of the breakout is 500 mils. | |
| Motherboard Trace Impedance (microstrip and stripline) | 50 Ohms +/- 15% | |
| Add-in card Impedance (microstrip and stripline) | 57 Ohms +/- 15% | |
| Stripline Trace Spacing | 10 mils, from edge to edge | |
| Microstrip Trace Spacing | 15 mils, from edge to edge | |
| Group Spacing | Spacing from other groups: 25 mils minimum edge-to-edge | |
| Trace Length 1 TL1: From 80331 signal Ball to first connector | 1" minimum - 7.0" maximum | 1" minimum - 6.5" maximum |

Table 24. PCI 33 MHz Slot Routing Recommendations (Sheet 2 of 2)

| | | |
|----------------------------------------------------------|----------------------------------------------------------------------------------------------------------------------------------|-------------------------------|
| Trace Length TL2 to TL5 between connectors. | 0.8" minimum - 1.5" maximum | |
| Trace Length TL_AD1 to TL_AD5 from connector to receiver | 0.75" minimum - 1.5" maximum | 1.75" minimum - 2.75" maximum |
| Length Matching Requirements: | No length matching is required among datalines. For length matching for clocks, refer clock guidelines Table 8 . | |
| Number of vias | Four vias maximum | |

6.4.18 PCI 33 MHz Embedded Mode Topology

Figure 33 and Table 25 provides routing details for a topology with for an embedded PCI 33 MHz design.

Figure 33. PCI 33 MHz Embedded Mode Routing Topology

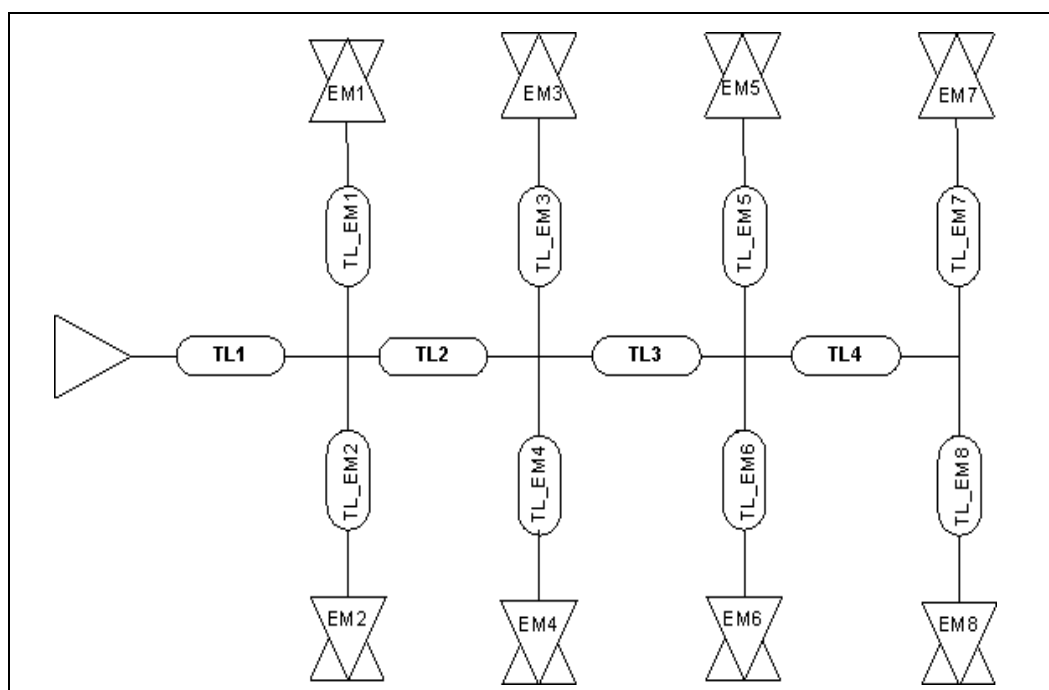

Table 25. PCI 33 MHz Embedded Routing Recommendations (Sheet 1 of 2)

| Parameter | Routing Guideline for Lower AD Bus |
|--------------------------------------------------------|-----------------------------------------------------------------------|
| Reference Plane | Route over an unbroken ground plane |
| Breakout | 5 mils on 5 mils spacing. Maximum length of the breakout is 500 mils. |
| Motherboard Trace Impedance (microstrip and stripline) | 50 Ohms +/- 15% |
| Add-in card Impedance (microstrip and stripline) | 60 Ohms +/- 15% |
| Stripline Trace Spacing | 10 mils, from edge to edge |
| Microstrip Trace Spacing | 15 mils, from edge to edge |

Table 25. PCI 33 MHz Embedded Routing Recommendations (Sheet 2 of 2)

| | |
|--------------------------------------------------------------|----------------------------------------------------------------------------------------------------------------------------------|
| Group Spacing | Spacing from other groups: 25 mils minimum edge-to-edge |
| Trace Length 1 TL1: From 80331 signal Ball to first junction | 4.5" maximum |
| Trace Length TL2 to TL4 between junctions | 1.5" minimum - 3.0" maximum |
| Trace Length TL_EM1 to TL_EM8 junction to embedded devices | 2.0" minimum - 3.0" maximum |
| Length Matching Requirements: | No length matching is required among datalines. For length matching for clocks, refer clock guidelines Table 8 . |
| Number of vias | Four vias maximum |

6.4.19 PCI 33 MHz Mixed Topology

Figure 34 and Table 26 provides routing details for a topology with for an embedded PCI 33 MHz design with slots.

Figure 34. PCI 33 MHz Mixed Mode Routing Topology

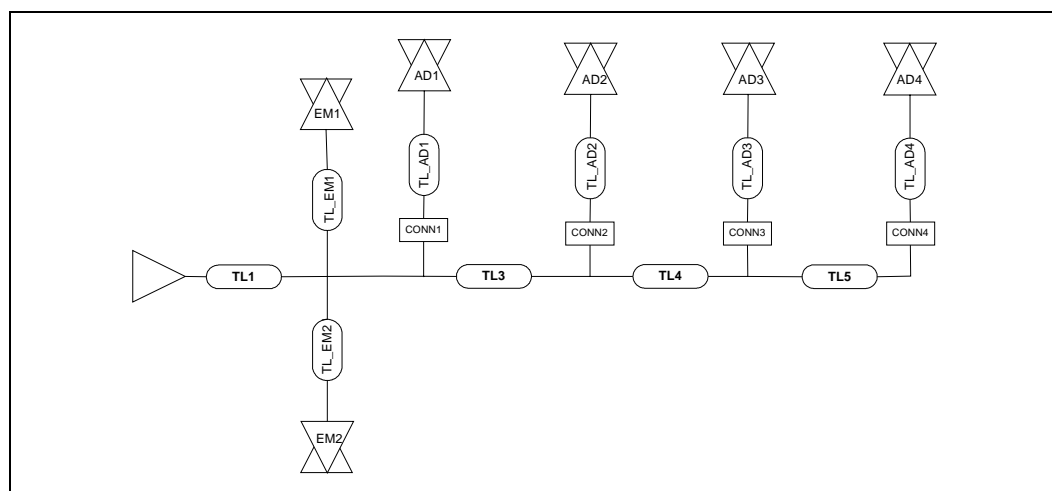

Table 26. PCI 33 MHz Mixed Mode Routing Recommendations (Sheet 1 of 2)

| Parameter | Routing Guideline for lower AD Bus | Routing Guideline for upper AD Bus |
|--------------------------------------------------------|-----------------------------------------------------------------------|------------------------------------|
| Reference Plane | Route over an unbroken ground plane | |
| Breakout | 5 mils on 5 mils spacing. Maximum length of the breakout is 500 mils. | |
| Motherboard Trace Impedance (microstrip and stripline) | 50 Ohms +/- 15% | |
| Add-in card Impedance (microstrip and stripline) | 57 Ohms +/- 15% | |
| Stripline Trace Spacing | 10 mils, from edge to edge | |
| Microstrip Trace Spacing | 15 mils, from edge to edge | |
| Group Spacing | Spacing from other groups: 25 mils minimum edge-to-edge | |

Table 26. PCI 33 MHz Mixed Mode Routing Recommendations (Sheet 2 of 2)

| Parameter | Routing Guideline for lower AD Bus | Routing Guideline for upper AD Bus |
|---------------------------------------------------------|----------------------------------------------------------------------------------------------------------------------------------|------------------------------------|
| Trace Length 1 TL1: 80331 signal Ball to 1st junction | 1.0" minimum - 5.5" maximum | 1.0" minimum - 5.5" maximum |
| Trace Length TL2 from 1st junction to 1st PCI connector | 1.5 - 4.0" maximum | |
| Trace Length TL3 to TL5 between connectors | 0.75" minimum - 1.5" maximum | 1.75" minimum - 2.75" maximum |
| Length Matching Requirements | No length matching is required among datalines. For length matching for clocks, refer clock guidelines Table 8 . | |
| Number of vias | Four vias maximum | |

Memory Controller

7

The Memory Controller allows direct control of a DDR SDRAM memory subsystem. It features programmable chip selects and support for error correction codes (ECC). The memory controller can be configured for DDR SDRAM at 333 MHz and DDR-II at 400MHz. The memory controller supports pipelined access and arbitration control to maximize performance. The memory controller interface configuration support includes Unbuffered DIMMs, Registered DIMMs, and discrete DDR SDRAM devices.

External memory can be configured as host addressable memory or private 80331 memory utilizing the Address Translation Unit and Bridge.

7.1 DDR Bias Voltages

The 80331 supports 2.5 V DDR memory and 1.8V for DDRII. [Table 27](#) lists the minimum/maximum values for the DDR memory bias voltages and [Table 28](#) lists the minimum/maximum values for the DDR II memory bias voltages.

Table 27. DDR Bias Voltages

| Symbol | Parameter | Minimum | Maximum | Units |
|-------------------|------------------------------------------------------------------------|-----------------------|-----------------------|-------|
| V _{CC25} | 2.5 V Power balls to be connected to a 2.5 V power board plane. | 2.3 | 2.7 | V |
| V _{DDQ} | I/O Supply Voltage | 2.3 | 2.7 | V |
| V _{REF} | Memory I/O Reference Voltage | $V_{CC25} / 2 - 0.05$ | $V_{CC25} / 2 + 0.05$ | V |
| V _{TT} | DDR Memory I/O Termination Voltage | $V_{REF} - 0.04$ | $V_{REF} + 0.04$ | V |

Table 28. DDR II Bias Voltage

| Symbol | Parameter | Minimum | Maximum | Units |
|-------------------|--------------------------------------------------------------------------|-----------------------|-----------------------|-------|
| V _{CC18} | 1.8 V Power balls to be connected to the 1.8 V power board plane. | 1.7 | 1.9 | V |
| V _{DDQ} | I/O Supply Voltage | 1.7 | 1.9 | V |
| V _{REF} | Memory I/O Reference Voltage | $V_{CC18} / 2 - 0.05$ | $V_{CC18} / 2 + 0.05$ | V |
| V _{TT} | DDR Memory I/O Termination Voltage | $V_{REF} - 0.04$ | $V_{REF} + 0.04$ | V |

7.2 Intel® 80331 I/O Processor DDR Overview

80331 with the DDR-SDRAM memory sub-system needs continuous ground referencing for all DDR signals. The DDR channel requires the referencing stack-up to allow ground referencing on all of the DDR signals from the 80331 to the parallel termination at the end of the channel.

Note: Leave unused M_CKs and M_CK#s unconnected.

The 80331 signal integrity specifications are for a single DIMM only for both DDR333 and DDR II 400. The DIMM topology supported for the recommendations listed in this section are for x8 single / double banks and x16 single/double banks.

DDR333 = single DIMM and supports both Buffered / Unbuffered DIMM

DDR II 400 = single DIMM and supports Buffered DIMM

Table 29 details the 80331 Core Speed and DDR/DDR II memory configuration.

Table 29. Core Speed and Memory Configuration

| Core/DDR | DDR333 | DDR-II 400 |
|----------|--------|------------|
| Low | 500MHz | 500MHz |
| Medium | 667MHz | N/A |
| High | N/A | 800MHz |

The DDR interface is divided up into three groups that each have special routing guidelines:

- Source synchronous signal group: DQ/DQS/DQM/CB signals
- Clocked: M_CK signals
- Control signals: Address/RAS/CAS/CS/WE/CKE signals

7.3 DDR 333 Signal Integrity Simulation Conditions

- Motherboard 50 ohm single ended impedance stackup +/- 15% tolerance.
- Add-in Card 60 ohm single ended impedance stackup +/- 15% tolerance.
- Clock Target Differential Impedance 100 ohms and 50 ohms single-ended impedance.
- Memory Model Micron T17A_DQ and Intel generic models.
- PLL Clock - Pericom* CDCBV857, PI6DCV16859.
- DIMM models and topologies used the JEDEC model as a reference.
- For unbuffered embedded and post PLL/register the standard recommendations were used as a reference.
- Spacing recommendations are for trace edge to edge except for differential pairs in which center to center was specified.
- Signal Quality analysis covered for Rising flight time, Falling flight time, Low to high ring-back (noise margin high), High to Low ring-back (noise margin Low), and Low and High Overshoot.
- Crosstalk Analysis was performed for all the major interfaces with actual package models.
- Frequency: 167MHz (DDR 333 MT/s).
- Connector –E SPICE of DIMM Connector (Derived from SPICE Circuit)
- Package - Actual extracted Package Model used.

The topologies simulated are listed in [Table 30](#).

Table 30. Simulated DDR 333 Topologies

| DIMM | Embedded |
|------------------------------------------------------------------------------------------------------------------|-----------------------------------------------------------------------------------------------------------------------------------------------------------------------------------------------|
| 1. DQ/DQS <ul style="list-style-type: none"> • Read- RAW A, RAWB • Write -RAW A, RAW B | 1. DQ/DQS <ul style="list-style-type: none"> • Read- Single Bank • Write - Single Bank |
| 2. Clock <ul style="list-style-type: none"> • Buffered • Unbuffered | 2. Clock <ul style="list-style-type: none"> • Buffered • Unbuffered • Post-PLL • PLL to SDRAM • PLL to Register • PLL to Feedback |
| 3. Address/CMD <ul style="list-style-type: none"> • Registered • Unbuffered - RAWA, RAWB | 3. Address/CMD <ul style="list-style-type: none"> • Registered • Unbuffered - Single bank ECC and non ECC • Post Register - single bank ECC and non ECC |

7.3.1 DDR 333 Stackup Example

Table 31 below provides an example of a table of recommended topologies for motherboard and add-in card eight layer PCB designs. Figure 35 provides an example of a cross section used to implement 100 ohm differential trace impedance. Throughout this section the important recommendation to meet is the trace impedance. The example in Table 31 is provided as a reference.

Table 31. Example Topologies for DDR Trace

| Topology | Trace Width (mils) | Min Trace Spacing (mils) | Trace Impedance (ohms) | Preferred signals | Board Type |
|----------------------------|--------------------|--------------------------|------------------------|------------------------|--------------------|
| Microstrip (layers 1 or 8) | 5 | 5 | | Breakout | Motherboard/Add-in |
| | 7 | 12 | 45 | Address/ CMD/Control | Motherboard/Add-in |
| | 6 | 12 | 50 | | Motherboard/Add-in |
| | 4 | 12 | 60 | | Motherboard/Add-in |
| | 5 (note 1) | 20 | 100 differential | Differential Clock/DQS | Motherboard/Add-in |
| Stripline (layers 3 or 6) | 5 | 5 | | Break out | Motherboard/Add-in |
| | 6 | 12 | 45 | DQ/DQS/CB | Motherboard |
| | 5 | 12 | 50 | | Motherboard card |
| | 7 | 12 | 45 | DQ/DQS/CB | Add-in card |
| | 6 | 12 | 50 | | Add-in card |
| | 4 | 12 | 60 | | Add-in card |
| | 4 (note 2) | 20 | 100 Ohm | Differential Clocks | Motherboard* |
| | 5 (note 3) | 20 | 100 Ohm | Differential Clock | Add-in card* |

1. Microstrip Differential Lines: Motherboard/Add-in 100 ohm: Constructed by two microstrips of 5 mils traces separated by center to center distance of 13 mils as shown in [Figure 35](#).
2. Strip Differential Lines: Motherboard Stripline 100 ohms: Constructed by two striplines of 4 mils traces separated by center to center distance of 12 mils as shown in [Figure 35](#).
3. Strip Differential Lines: Add-in stripline 100 ohms: Constructed by two striplines of 4 mils traces separated by center to center distance of 13 mils as shown in [Figure 35](#).

Figure 35. 100 ohm Differential Trace

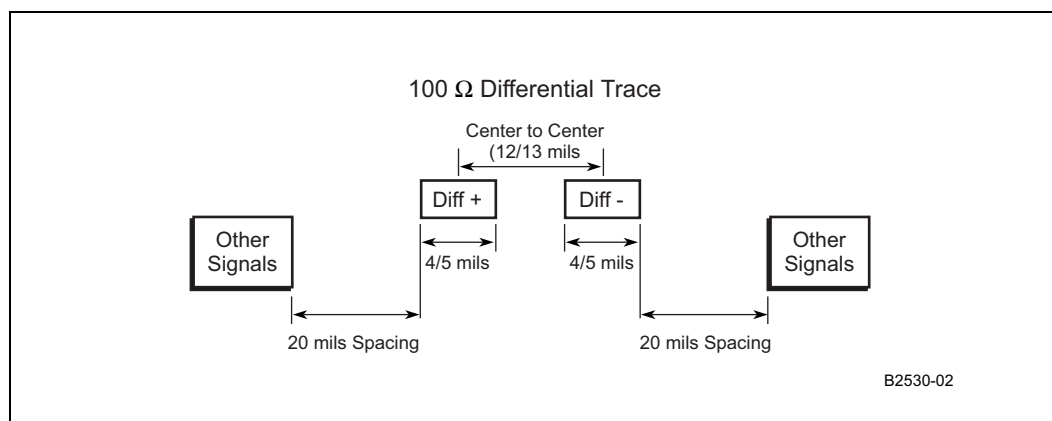

7.4 DDR Layout Guidelines

The following sections provide layout information for 80331 DDR333 configuration.

7.4.1 Source Synchronous Signal Group

The guidelines below are for the source synchronous signal group which includes Data bits **DQ**, check bits **CB**, data mask **DM**, and **DQS** associated strobe.

The 80331 source synchronous signals are divided into groups consisting of data bits **DQ** and check bits **CB**. There is an associated strobe **DQS** for each **DQ**, **DM** and **CB** group. When data masking is not used system memory **DM** pins on the DDR needs to be tied to ground. The grouping is as follows for the different memory configurations:

Table 32. x64 DDR Memory Configuration

| Data Group | Associated Strobe |
|------------------|-------------------|
| DQ[7:0], DM[0] | DQS0 |
| DQ[15:8], DM[1] | DQS1 |
| DQ[23:16], DM[2] | DQS2 |
| DQ[31:24], DM[3] | DQS3 |
| DQ[39:32], DM[4] | DQS4 |
| DQ[47:40], DM[5] | DQS5 |
| DQ[55:48], DM[6] | DQS6 |
| DQ[63:56], DM[7] | DQS7 |

Table 33. x72 DDR Memory Configuration

| Data Group | Associated Strobe |
|-----------------------|-------------------|
| DQ[7:0], DM[0] | DQS0 |
| DQ[15:8], DM[1] | DQS1 |
| DQ[23:16], DM[2] | DQS2 |
| DQ[31:24], DM[3] | DQS3 |
| DQ[39:32], DM[4] | DQS4 |
| DQ[47:40], DM[5] | DQS5 |
| DQ[55:48], DM[6] | DQS6 |
| DQ[63:56], DM[7] | DQS7 |
| CB[7:0], DM[8] | DQS8 |

7.4.1.1 Routing Requirements

Table 34 and Table 35, and Figure 36 and Figure 37 show the routing and termination requirements for the source synchronous signal group.

Figure 36. Source Synchronous Length Matching

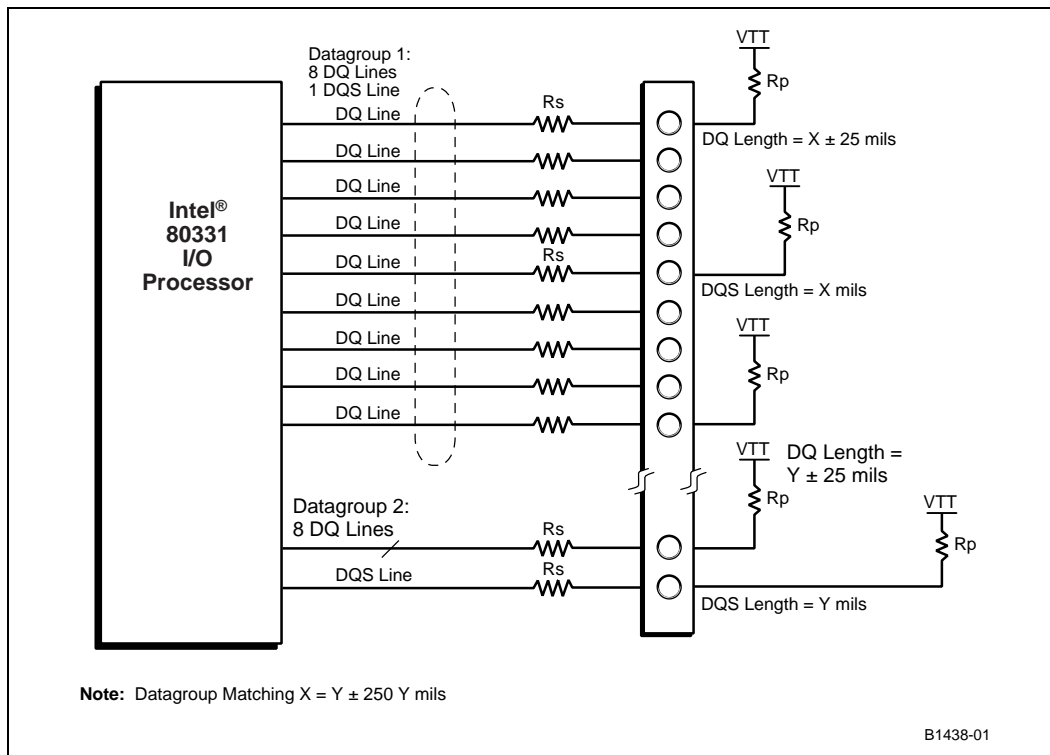

Table 34. Source Synchronous Termination Requirements

| DDR SDRAM | R Series | R Parallel |
|-----------|------------------|------------------|
| | 22.1 +/- 5% ohms | 51.1 +/- 5% ohms |

Figure 37. Data Group Length Matching

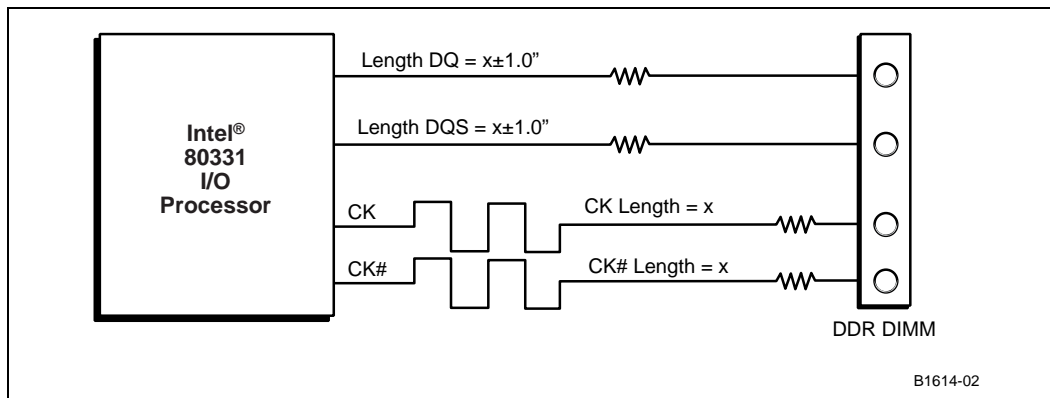

Table 35. Source Synchronous Routing Recommendations

| Parameter | Routing Guideline |
|--------------------------------------------------------------|--------------------------------------------------------------------------------------------------------------------------------------------------------------------------------------------------------------------------------------------------------------------------------------------------------------------------------------------------------------------------------------------------------------------------|
| Reference Plane | Stripline: Route over unbroken ground plane Microstrip Routing: Route over unbroken power or ground plane |
| Preferred Layer | Stripline |
| Topology | Stripline (stubs needs to be <250 mils) |
| Breakout | 5 mils x 5 mils Maximum length of breakout region of 500 mils. |
| Strip line Trace Impedance | 45 ohms +/- 15% OR 50 OHMS +/- 15%. |
| Strip Line Trace Spacing (trace edge to neighbor trace edge) | <ul style="list-style-type: none"> • 5 mils spacing acceptable between pins and breakout regions • >12 mils edge to edge between any DQ/DQS signals • > 20 mils (edge to edge) maintained from any other groups |
| Trace Lengths | Refer to DIMM DQ/DQS Topology Figure 38 and Figure 39 |
| DQ Group Spacing | Spacing from other DQ groups 20 mils minimum |
| Series Resistor Rs | 22.1 Ω +/- 5% |
| Parallel Termination | <ul style="list-style-type: none"> • Single VTT termination of 51.1 Ω +/- 5% to VTT (1.25V) or <ul style="list-style-type: none"> • Split terminations of 100 ohms +/- 5% to 2.5V and 100 ohms +/- 5% to ground. • Place the VTT termination in a VTT island. |
| Length Matching Requirements: within DQS Group | +/- 0.050" within DQS group |
| Length Matching Requirements: All DQ/DQS lines to Clock | <ul style="list-style-type: none"> • The package lengths from Die to Ball provided in Table 37 must be accounted for when length matching • When M_CK is routed on a stripline layer, DQS should be routed to within +/- 1.5" of its corresponding M_CK • When M_CK is routed on a micro-strip layer, DQS should be routed to within +/- 1.0" of its corresponding M_CK |
| Routing Guideline 1 | Route all data signals and their associated strobes on the same layer. |
| Routing Guideline 2 | Minimize layer changes (two vias or less) |
| Routing Guideline 3 | Do not share series terminator resistor packs between DQ/DQS and Address. |
| Number of Vias | 2 (Equal number of vias between DQ and its respective DQS signal) |

Table 36. DIMM DQ/DQS Topology Lengths

| Traces | Description | Layer | Minimum Length | Maximum Length | Trace Impedance | Spacing | Notes |
|--------|-------------|------------|----------------|----------------|------------------------------------------|---------|---------------------------------------------|
| TL1 | Breakout | Microstrip | | 0.5" | | 5 mils | |
| TL2 | Lead-in | Microstrip | 2 " | 8" | 45 ohms +/- 15% or 50 ohms +/- 15% | 12 mils | Lead-in traces are preferred as striplines. |
| TL3 | | Microstrip | 0.25" | 0.5" | Same as TL2 | | Fan out for series termination |
| TL4 | Vtt | Microstrip | 0.15 | 0.5" | | 5 mils | Vtt Termination |

Table 37. Die to Ball Internal Lengths

| Signal Description | Lengths (mils) |
|--------------------|----------------|
| BA[0] | 366.64 |
| BA[1] | 400.1 |
| CAS# | 435.86 |
| CB[0] | 576.97 |
| CB[1] | 576.96 |
| CB[2] | 576.99 |
| CB[3] | 576.99 |
| CB[4] | 577.86 |
| CB[5] | 576.95 |
| CB[6] | 577 |
| CB[7] | 577.9 |
| CKE[0] | 768.12 |
| CKE[1] | 788.7 |
| CS[0]# | 432.83 |
| CS[1]# | 482.04 |
| DDR_VREF | 1287.52 |
| DDRCRES0 | 602.21 |
| DDRIMPCRES | 674.9 |
| DDRRES[1] | 648.04 |
| DDRRES[2] | 751.97 |
| DDRSLWCRES | 600.29 |
| DM[0] | 800.63 |
| DM[1] | 940.23 |
| DM[2] | 674.86 |
| DM[3] | 651.68 |
| DM[4] | 651.68 |
| DM[5] | 702 |

Table 37. Die to Ball Internal Lengths

| Signal Description | Lengths (mils) |
|--------------------|----------------|
| DM[6] | 805.36 |
| DM[7] | 767.5 |
| DM[8] | 577.92 |
| DQ[0] | 801.6 |
| DQ[1] | 801.46 |
| DQ[10] | 940.14 |
| DQ[11] | 939.24 |
| DQ[12] | 939.27 |
| DQ[13] | 939.28 |
| DQ[14] | 940.03 |
| DQ[15] | 940.19 |
| DQ[16] | 674.37 |
| DQ[17] | 675.08 |
| DQ[18] | 674.24 |
| DQ[19] | 674.44 |
| DQ[2] | 801.58 |
| DQ[20] | 674.16 |
| DQ[21] | 674.67 |
| DQ[22] | 674.2 |
| DQ[23] | 675.04 |
| DQ[24] | 652.55 |
| DQ[25] | 652.64 |
| DQ[26] | 651.67 |
| DQ[27] | 651.72 |
| DQ[28] | 652.1 |
| DQ[29] | 652.61 |
| DQ[3] | 800.66 |
| DQ[30] | 652.08 |
| DQ[31] | 652.58 |
| DQ[32] | 651.65 |
| DQ[33] | 650.81 |
| DQ[34] | 651.69 |
| DQ[35] | 650.74 |
| DQ[36] | 650.74 |
| DQ[37] | 651.71 |
| DQ[38] | 650.76 |
| DQ[39] | 650.73 |

Table 37. Die to Ball Internal Lengths

| Signal Description | Lengths (mils) |
|--------------------|----------------|
| DQ[4] | 800.6 |
| DQ[40] | 701.56 |
| DQ[41] | 702.02 |
| DQ[42] | 701.74 |
| DQ[43] | 702.25 |
| DQ[44] | 701.86 |
| DQ[45] | 702.01 |
| DQ[46] | 702.03 |
| DQ[47] | 701.93 |
| DQ[48] | 806.13 |
| DQ[49] | 805.43 |
| DQ[5] | 800.63 |
| DQ[50] | 805.88 |
| DQ[51] | 805.96 |
| DQ[52] | 806.17 |
| DQ[53] | 806.17 |
| DQ[54] | 805.54 |
| DQ[55] | 805.34 |
| DQ[56] | 767.47 |
| DQ[57] | 767.45 |
| DQ[58] | 768.35 |
| DQ[59] | 767.46 |
| DQ[6] | 800.62 |
| DQ[60] | 767.48 |
| DQ[61] | 767.47 |
| DQ[62] | 767.63 |
| DQ[63] | 767.51 |
| DQ[7] | 800.63 |
| DQ[8] | 940.16 |
| DQ[9] | 940.15 |
| DQS[0] | 801 |
| DQS[1] | 939.25 |
| DQS[2] | 674.68 |
| DQS[3] | 652.66 |
| DQS[4] | 650.81 |
| DQS[5] | 701.98 |
| DQS[6] | 805.94 |

Table 37. Die to Ball Internal Lengths

| Signal Description | Lengths (mils) |
|--------------------|----------------|
| DQS[7] | 767.45 |
| DQS[8] | 576.94 |
| DQS[0]# | 800.66 |
| DQS[1]# | 939.23 |
| DQS[2]# | 675.03 |
| DQS[3]# | 652.62 |
| DQS[4]# | 650.75 |
| DQS[5]# | 701.68 |
| DQS[6]# | 806.15 |
| DQS[7]# | 767.44 |
| DQS[8]# | 577.9 |
| M_CK[0] | 616.41 |
| M_CK[0]# | 616.27 |
| M_CK[1] | 762.67 |
| M_CK[1]# | 762.65 |
| M_CK[2] | 597.08 |
| M_CK[2]# | 597.24 |
| M_RST# | 760.27 |
| WE# | 403.92 |
| RAS# | 290.55 |
| MA[0] | 326.8 |
| MA[1] | 447.68 |
| MA[10] | 352.22 |
| MA[11] | 390.14 |
| MA[12] | 620.5 |
| MA[13] | 485.18 |
| MA[2] | 338.39 |
| MA[3] | 483.4 |
| MA[4] | 505.56 |
| MA[5] | 629.68 |
| MA[6] | 634.85 |
| MA[7] | 403.63 |
| MA[8] | 638.37 |
| MA[9] | 393.04 |
| ODT[0] | 372.29 |
| ODT[1] | 224.37 |

Figure 38. DIMM DQ/DQS Topology

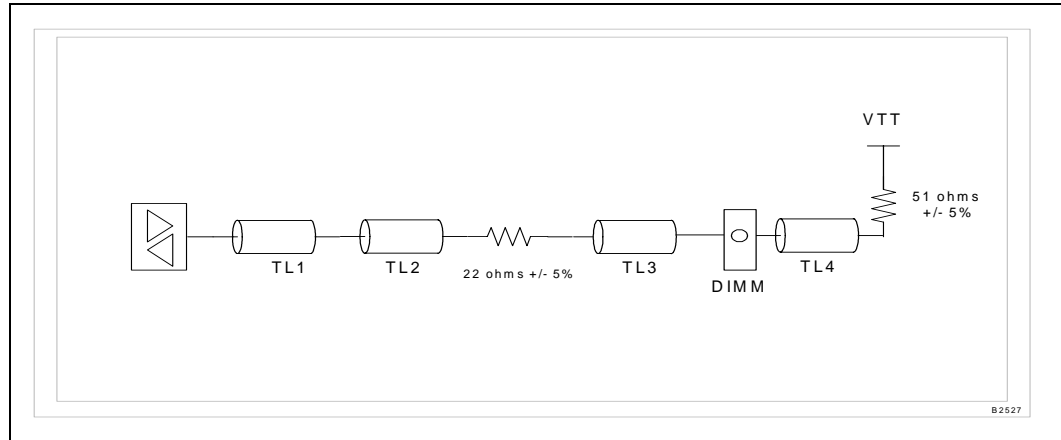
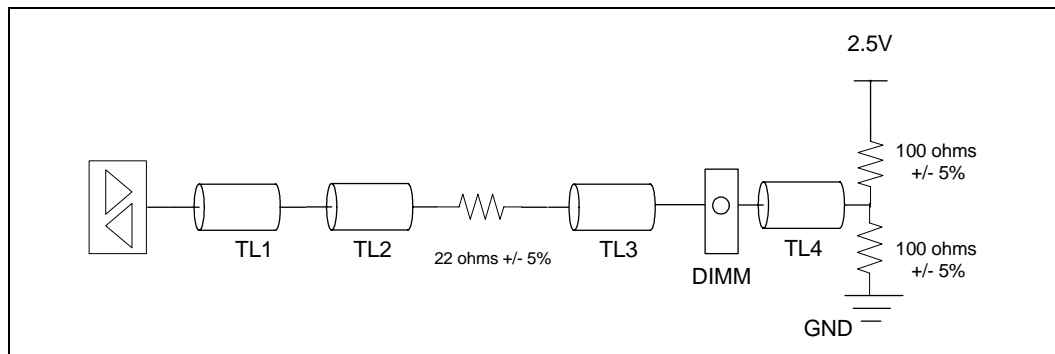

Table 38. DIMM DQ/DQS Split Termination Topology Lengths

| Traces | Description | Layer | Minimum Length | Maximum Length | Trace Impedance | Spacing | Notes |
|--------|-------------|--------------------------|----------------|----------------|------------------------------------------|---------|---------------------------------------------|
| TL1 | Breakout | Microstrip/ Stripline | | 0.5" | | 5 mils | |
| TL2 | Lead-in | Microstrip | 2 " | 8" | 45 ohms +/- 15% or 50 ohms +/- 15% | 12 mils | Lead-in traces are preferred as striplines. |
| TL3 | | Microstrip | 0.25" | 0.5" | Same as TL2 | | Fan out for series termination |
| TL4 | Vtt | Microstrip | 0.15 | 0.5" | | 5 mils | Split termination |

Figure 39. DIMM DQ/DQS Split Termination Topology



7.4.2 Clock Signal Groups

The 80331 drives the command clock signals required by the DDR interface. The source-clocked signals are “clocked” into the DIMM using the command clock signals. The 80331 drives the command clock signals and the source-clocked signals together, these signals can be source clocked. The 80331 drives the command clock in the center of the valid window, and the source-clocked signals propagate with the command clock signal. An important timing specification is the difference between the command clock flight time and the source clocked signal flight time. The absolute flight time is not as critical.

The common clock signal group contains **M_CK[2:0]** and **M_CK[2:0]#**. The following tables and figure show the routing requirements for the clock signal group.

Table 39. DIMM Clocked Signal Group Termination

| DDR SDRAM | Rs Series | Rp Parallel |
|-----------|------------------------------------------|-------------|
| | 22.1 +/- 5% ohms (non-buffered DDR only) | none |

Table 40. Clock Signal Group Registered/Unbuffered DIMM Routing Requirements

| Parameter | Routing Guideline |
|------------------------------------------------------------------------------------------------------------------------|-------------------------------------------------------------------------------------------------------------------------------------------------------------------------------------------------------------------------------------------------------------------------------------------------------------------------------------|
| Reference Plane Preferred Topology | Route over unbroken ground plane Differential Microstrip (preferred) or differential stripline |
| Preferred Topology | Stripline routing is recommended for the clock signals. Micro-strip is also acceptable with strict adherence to all routing recommendations. |
| Breakout trace width and spacing | 5 mils x 5 mils routed as differential pair |
| Microstrip Trace Width | Differential: Trace impedance of 100 ohms Refer to Figure 41 |
| Trace Spacing (edge to edge) | 5 mils for breakout 5 mils from one clock M_CK of the differential pair M_CK#. >20 mils between the other signals or vias including other clock pairs. |
| Package Trace Length Breakout Trace Length (TL1) Lead-in to Connector Length (TL2) | See Table 37 for the net length details. <= .5" 2.0" to 10" (correlated within +/- 1.0" of DQ/DQS and command trace lengths) |
| Termination: - Buffered Termination - Un-Buffered Termination | None required 22.1 ohms +/- 5% series termination on each differential segment after the breakout. |
| Length matching Requirements: | The package lengths from Die to Ball provided in Table 37 must be accounted for when length matching |
| <ul style="list-style-type: none"> • Within differential clock pairs | <ul style="list-style-type: none"> • +/- 0.025" max. within Pairs [Intra-pair] |
| <ul style="list-style-type: none"> • With respect to the DQ/DQS group (from die to DIMM connector) | <ul style="list-style-type: none"> • +/- 1.5" max. when M_CK is routed Stripline • +/- 1.0" max. when M_CK is routed Micro-strip |
| <ul style="list-style-type: none"> • With respect to Address/Command group (from die to DIMM connector) | <ul style="list-style-type: none"> • For total capacitive loads greater than 36pF, M_CK trace lengths must be 2.0" to 3.0" longer than all ADD/CMD/CTRL trace lengths • For capacitive loads less than or equal to 36pF, M_CK trace lengths must be 1.0" to 3.0" longer than all ADD/CMD/CTRL trace lengths |
| <ul style="list-style-type: none"> • Among Unbuffered Clock Pairs | <ul style="list-style-type: none"> • +/- 0.1" max. between the 3 pairs of Unbuffered Clocks |
| Series Resistor Rs | <ul style="list-style-type: none"> • 22.1 +/- 5% ohms unbuffered • no series resistor required for registered DIMM's |
| Parallel Resistor Rp | <ul style="list-style-type: none"> • no parallel resistor required |
| Routing Guideline 1 | Clock signals' polarity needs to be alternated. |
| Routing Guideline 2 | Maximum of 2 pair of vias from controller to DIMM |
| Routing Guideline 3 | Route clock as differential impedance of 100 ohms with single ended impedance of 50 ohms |

Table 41. Registered DIMM Clock Topology Lengths

| Traces | Description | Layer | Minimum Length | Maximum Length | Trace Impedance | Spacing | Notes |
|--------|-------------|------------|----------------|----------------|-----------------------------------------|---------------------|-------------------------------------|
| TL1 | Breakout | Microstrip | | 0.5" | | 5 mils | 5 mils trace width OK for breakout. |
| TL2 | Lead-in | Microstrip | 2 " | 10" | Differential Impedance 100 ohms +/- 15% | 20 mils from others | Route as differential pairs |

Figure 40. DDR 333 Registered DIMM Clock Topology

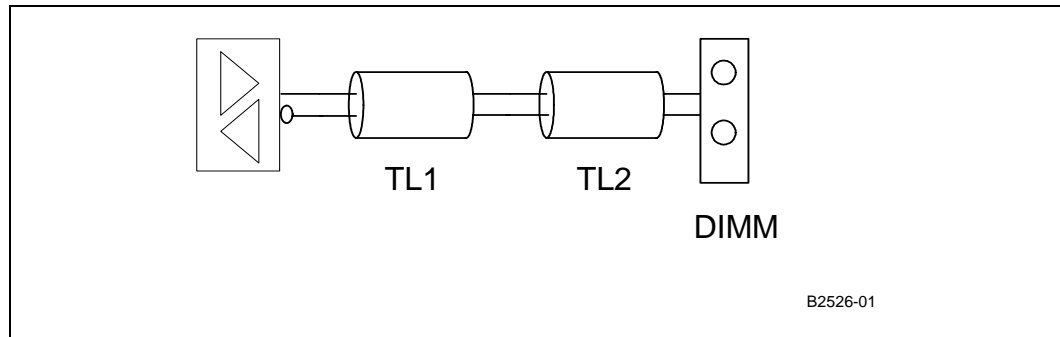

Table 42. DDR 333 Unbuffered DIMM Clock Topology Lengths

| Traces | Description | Layer | Minimum Length | Maximum Length | Trace Impedance | Spacing | Notes |
|------------------------------|-------------|--------------------------|----------------|----------------|-----------------------------------------|---------------------|-------------------------------------------------------------------------------------------------------------------------------|
| TL1 (all 3 clock pairs) | Breakout | Microstrip | | 0.5" | | 5 mils | 5 mils trace width OK for breakout. |
| TL2 (all 3 x clock pairs) | Lead-in | Microstrip/ Stripline | 2 " | 10" | Differential Impedance 100 ohms +/- 15% | 20 mils from others | <ul style="list-style-type: none"> Route as differential pairs. Series termination of 22 ohms +/- 5%. |

NOTE: Length matching should be done from die to DIMM connector

1. Between intra pairs +/- 25 mils
2. Between clock pairs M_CK0, M_CK1, M_CK2 +/- 100mils on unbuffered clocks
3. DQS lengths are within +/- 1.5 " max. of MCK for stripline
4. DQS lengths are within +/- 1.0 " max. of MCK for stripline
5. Address/Command/Control lengths are with-in 2" to 3" less than MCK
6. Any address/command/control lengths greater than M_CK from die to DIMM is not guaranteed for x2 bank unbuffered configurations.

Figure 41. DDR 333 Unbuffered DIMM Clock Topology

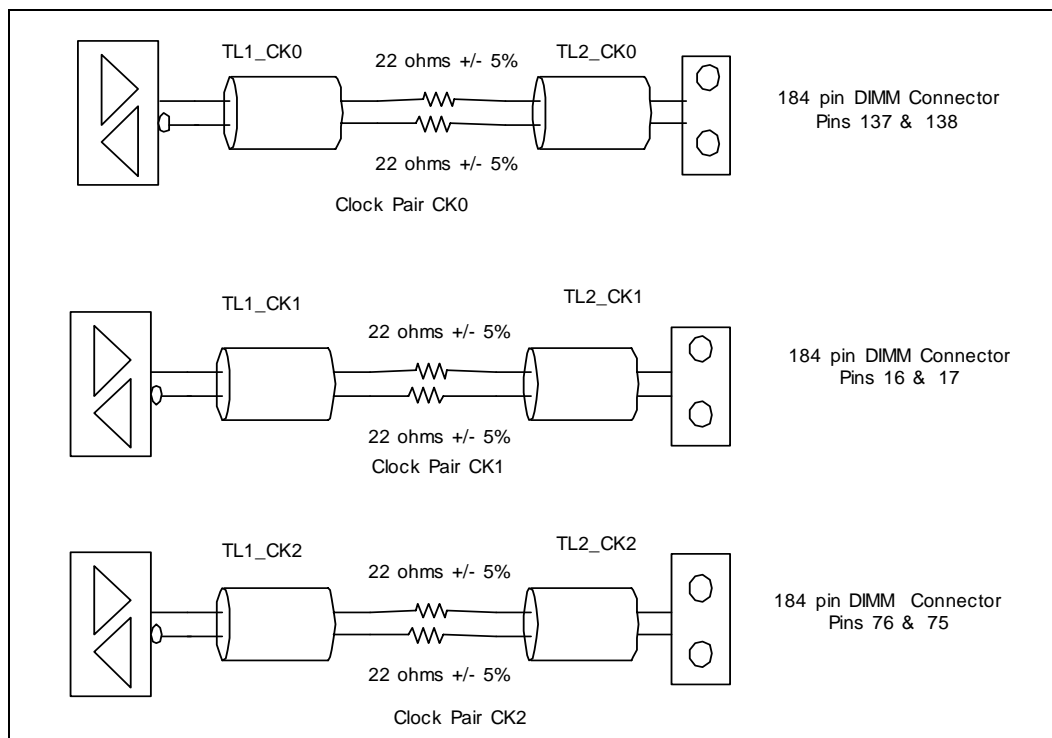

7.4.2.1 Control Signals Termination

The control signal group includes **RAS#**, **CAS#**, **WE#**, **BA[1:0]**, **MA[12:0]**, **CS[1:0]#**, and **CKE[1:0]**. The series and parallel termination is shown in [Table 43](#).

Table 43. Source Clocked Signal Routing

| DDR SDRAM | Rs Series | Rp Parallel |
|-----------|-----------|-------------|
| | | |

7.4.2.1.1 Control Signal Routing Guidelines

Figure 42 and [Table 44](#) provide the routing guidelines for the source clocked group of signals.

Figure 42. Trace Length Requirements for Source Clocked Routing

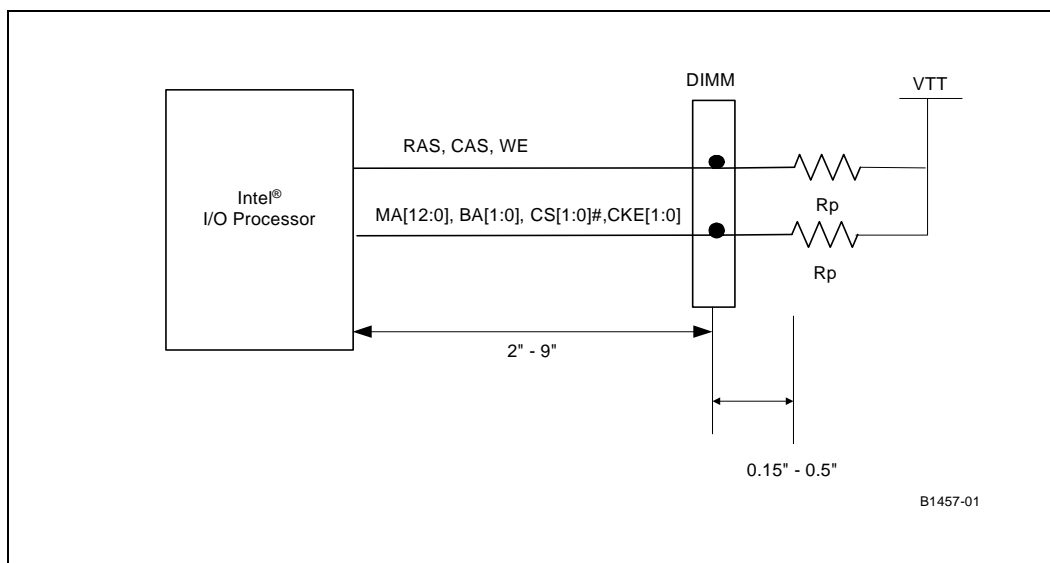

Table 44. Control Signals Routing Guidelines

| Parameter | Routing Guideline |
|-----------------------------------------------------------------------------------------------------------------------------------------------|-----------------------------------------------------------------------------------------------------------------------------------------------------------------------------------------------------------------------------------------------------------------------------------------------------------------------------------------------------------------------------------------------------------|
| Reference Plane | Route over unbroken ground plane is preferred. (Refer to Table for alternatives if this is not feasible). |
| Preferred Topology | Micro-strip only for Un-buffered memory configurations Either Micro-strip or Stripline for Buffered DIMMs and lightly loaded Un-buffered DIMMs (i.e. single bank or dual bank w/ less than or equal to 36pF input capacitance). |
| Breakout Trace Width and Spacing | 5 mils x 5 mils acceptable through pin field and terminations |
| Trace Impedance | <ul style="list-style-type: none"> 45 ohms Motherboard/Add-in card impedance 50 ohms Motherboard/Add-in Card Impedance |
| Strip Line Trace Spacing (edge to edge) | <ul style="list-style-type: none"> Spacing within group 12 mils minimum 5 mils acceptable through pin field and terminations > 20 mils from the Clock/DQ/DQS groups |
| Series Resistor Rs | No series termination required |
| Parallel Resistor Rp | 51.1 +/- 5% ohms OR Split termination of 100 ohms +/- 5% terminated to 2.5V and 100 ohms +/- 5% terminated to ground Place Vtt terminations in a Vtt island after the DIMM |
| Package Trace Length: Breakout Trace Length (TL1): Lead-in to Connector Trace Length (TL2): Parallel Termination Route Length (TL3): | See Table 37 for package net length report and Table 45 for more details. ≤ 0.5" 2.0" to 9.0" 0.15" to 0.5" |
| Length Matching Requirements: | The package lengths from Die to Ball provided in Table 37 must be accounted for when length matching For total capacitive loads greater than 36pF, all ADD/CMD/CTRL trace lengths must be 2.0" to 3.0" shorter than M_CK's trace length For total capacitive loads less than or equal to 36pF, all ADD/CMD/CTRL trace lengths must be 1.0" to 3.0" shorter than M_CK's trace length |
| Routing Guideline 1 | Route these signals on the same layer as the M_CKs. |
| Routing Guideline 2 | Minimize layer changes (two vias or less) |

Figure 43. DDR 333 DIMM Unbuffered/Registered Address/CMD Topology Lengths

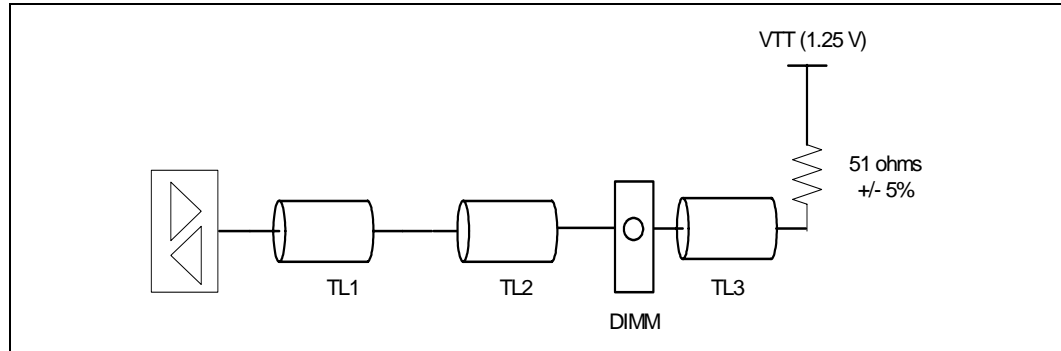

Table 45. Control Signal DIMM Topology Lengths

| Traces | Description | Layer | Minimum Length | Maximum Length | Trace Impedance | Spacing | Notes |
|--------|--------------------------------------|-------------------------|----------------|----------------|-----------------------------------|---------------------|------------------------------------------------------------------------------------------------------------------------------------------------------|
| TL1 | Breakout | Microstrip or stripline | | 0.5" | - | 5 mils | 5 mils trace width OK for breakout. |
| TL2 | Lead-in | Microstrip | 2 " | 8.5" | 45ohms +/- 15% 50 ohms +/- 15% | 12 mils from others | <ul style="list-style-type: none"> • Within the same group >12 mils • Any of the other groups (DQ/DQS/Clock) > 20 mils |
| TL3 | Vtt (preferred) or Split Termination | Microstrip | 0.15" | 0.5" | - | 5 mils | Single VTT termination in VTT island is preferred. |

7.4.3 Embedded Configuration

The following tables provide layout guidelines for applications in which the DDR 333 memory SDRAM components are placed directly on the board without a DIMM.

7.4.3.1 DDR 333 Source Synchronous Routine Guidelines

This section lists the recommendations for the DDR 333 embedded source synchronous routing. These signals include all the DQ/DQS signals. Refer to [Table 46](#) and [Table 47](#) for the lengths and matching requirements and [Figure 44](#) for the topology diagram. The topologies simulated are listed in [Table 30](#).

Table 46. DDR 333 Embedded Source Synchronous Routing Recommendations (Sheet 1 of 2)

| Parameter | Routing Guideline |
|------------------------------------------------------------------------------------------------------------------------|------------------------------------------------------------------------------------------------------------------------------------------------------------------------------------------------------------------------------------------------------------------------------------------------------------------------------|
| Reference Plane | Stripline routing: Route over unbroken ground plane Micro-strip routing: Route over unbroken ground or power plane |
| Preferred Topology | Stripline. Simulations show that stripline routing of the DQ and DQS signals provides the best solution space. Micro-strip routing is also acceptable. |
| Breakout Termination, Fan-in and Fanout width and spacing | 5 mils x 5 mils. Microstrip is recommended for pin escapes and terminations. |
| Trace Impedance | <ul style="list-style-type: none"> 45 ohm +/- 15% or 50 ohms +/- 15% |
| Trace Spacing (trace edge to edge) | <ul style="list-style-type: none"> 5 mils is acceptable for pin escapes and fan-in/fan-out from terminations. >12 mils between any DQ/DQS signals >20 mils must be maintained from any other groups |
| Package Trace Length: | The package lengths from Die to Ball provided in Table 37 must be accounted for when length matching. Refer to Table 47 for more details on segment lengths. |
| <ul style="list-style-type: none"> Breakout Trace Length (TL1) | ≤ 0.5" |
| <ul style="list-style-type: none"> Lead-in to Series Term. Trace Length (TL2) | 1.0" to 4.0" |
| <ul style="list-style-type: none"> Fan-in/ Fan-out from Series Termination Trace Length (TL3 & TL4) | ≤ 0.1" |
| <ul style="list-style-type: none"> Parallel Termination Trace Length (TL5) | 0.15" to 0.5" (placed directly after series termination fan-in) |
| <ul style="list-style-type: none"> Lead-in to SDRAM (TL6) | 1.0" to 4.0" |
| Length Matching: | <ul style="list-style-type: none"> The package lengths from Die to Ball provided in Table 37 must be accounted for when length matching. |
| <ul style="list-style-type: none"> With respect to the clock signal | <ul style="list-style-type: none"> When M_{CK} is routed on a stripline layer, DQS should be routed to within +/- 1.5" of its corresponding M_{CK} When M_{CK} is routed on a micro-strip layer, DQS should be routed to within +/- 1.0" of its corresponding M_{CK} |
| <ul style="list-style-type: none"> Length Matching within DQS group | <ul style="list-style-type: none"> +/- .05" within DQS group |
| Series Termination | 22 ohms +/- 5% |

Table 46. DDR 333 Embedded Source Synchronous Routing Recommendations (Sheet 2 of 2)

| Parameter | Routing Guideline |
|---------------------------|------------------------------------------------------------------------------------------------------------------------------------------------------------------------------------------------------------------------------------------------------------------------------------------------|
| Parallel Termination | 51 ohms +/- 5% <ul style="list-style-type: none"> • Place the VTT terminations in VTT island after the DIMM (trace length of 0.15" to 0.5"). or <ul style="list-style-type: none"> • Split termination of 100 ohms +/- 5% to 2.5 V and 100 ohms +/- 5% to ground |
| Routing Guideline 1 | Route all data signals and their associated strobes on the same layer. |
| Routing Guideline 2: Vias | ≤ 2 Minimize layer changes especially DQS signals. (two vias or less). Equal number of vias between DQ and its respective DQS signal. |

Figure 44. Embedded DDR 333 DQ/DQS Topology

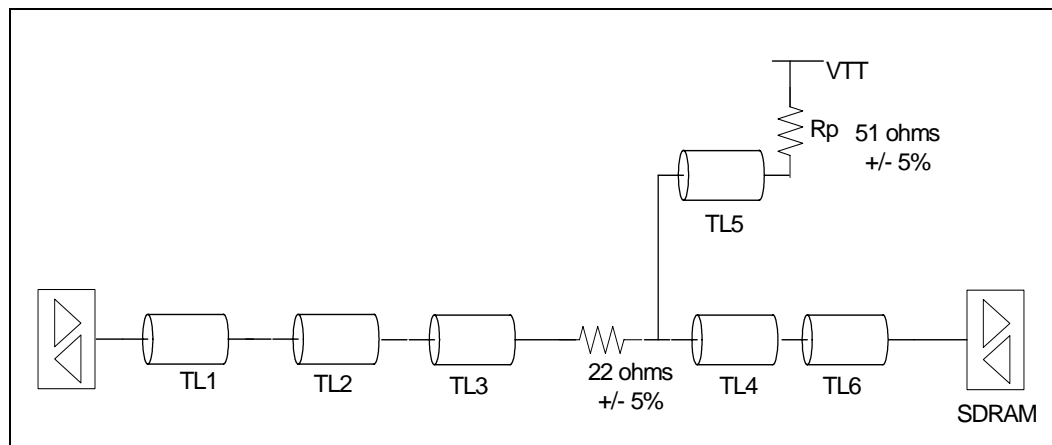

Table 47. Embedded DDR 333 DQ/DQS Topology Lengths

| Traces | Description | Layer | Minimum Length | Maximum Length | Trace Impedance | Spacing | Notes |
|--------|--------------------------|--------------------------|----------------|----------------|---------------------------------------------|---------|----------------------------------------------------------------------------------------------------------------------------------------------|
| TL1 | Breakout | Microstrip/ Stripline | 0" | 0.5" | - | 5 mils | 5 mil trace width breakout OK |
| TL2 | Lead-in | Stripline | 1 " | 4" | 45 ohms +/- 15% or 50 ohms +/- 15% | 12 mils | <ul style="list-style-type: none"> • Within the same group >12 mils • Any other groups (DQ/DQS/Clock) >20 mils |
| TL3 | | Microstrip | 0" | 0.1" | - | 5 mils | Fan out for series termination |
| TL4 | | Microstrip | 0" | 0.1" | - | 5 mils | Fan out for series termination |
| TL5 | VTT or Split Termination | Microstrip | 0.25" | 0.5" | - | 5 mils | Single VTT termination in VTT island is preferred |
| TL6 | Same as TL2 | Stripline | 1" | 4" | Same as TL2 | 12 mils | Same as TL2 |

Notes:

1. Series termination is recommended in the center of the lead-in length
2. Parallel termination with single VTT Termination is preferred than split termination
3. For single VTT termination (preferred) the resistor value = 51 ohms +/- 5%
4. For split termination, the value of the resistors are 100 ohms +/- 5% to 2.5V and 100 ohms +/- 5% to Ground.

7.4.3.2 DDR 333 Embedded Clock Routing Recommendations

This section lists the recommendations for the DDR 333 clock signals. Refer to Figure 45 for buffered clock topology, Figure 46 for unbuffered clock topology. Refer to Table 48 for a summary of DDR 333 embedded clock routing guidelines. Refer to Table 49 for a description of the segment lengths and matching requirements for buffered clock topology. Refer to Table 50 for a description of unbuffered clock topology information.

Figure 45. Embedded DDR 333 Buffered Clock Topology

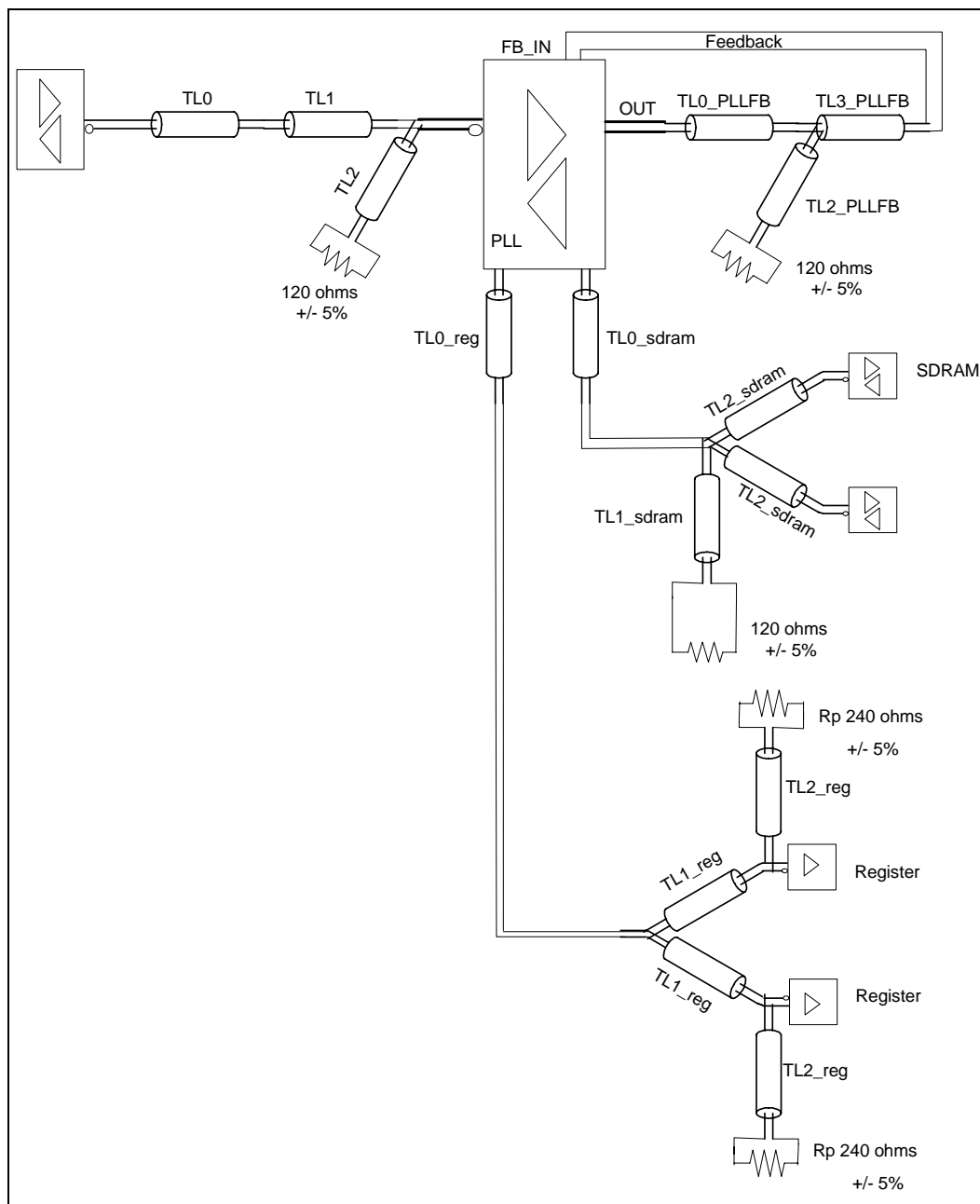

Table 48. DDR 333 Embedded Registered/Unbuffered Clock Routing Recommendations

| Parameter | Routing Guideline |
|---------------------------------------------------------------------------------------------------------------------------------|----------------------------------------------------------------------------------------------------------------------------------------------------------------------------------------------------------------------------------------------------------------------------------------------------------------------------------------------|
| Reference Plane | <ul style="list-style-type: none"> Route over unbroken ground plane |
| Preferred Topology | <ul style="list-style-type: none"> Stripline routing is recommended for the clock signals. Micro-strip will work with strict adherence to all routing recommendations. Careful simulation and timing analysis of ADD/CMD signals is recommended. |
| Breakout Termination, Fan-in and Fanout width and spacing | 5 mils x 5 mils. Microstrip is recommended for pin escapes and terminations. |
| Trace Impedance | Differential Target impedance of 100 Ohms +/-15% (Applies to both Buffered and Unbuffered Topologies) |
| Trace Spacing (trace edge to edge) | 5 mils. for breakout region >20 mils. between any other signals or vias including other clock pairs. |
| Registered Termination | None required |
| Un-buffered Termination | <ul style="list-style-type: none"> 22 ohms +/-5% series termination on each differential leg after breakout route Post PLL and Unbuffered SDRAM Clock areas to be Routed as T Point differential as per JEDEC Unbuffered and Registered Post PLL Clock Topology |
| Length matching Requirements: | <ul style="list-style-type: none"> The package lengths from Die to Ball provided in Table 37 must be accounted for when length matching. See respective registered Table 49 and unbuffered Table 50 tables Topology/ Trace Length tables for additional information. |
| <ul style="list-style-type: none"> Within Differential Clock pairs | <ul style="list-style-type: none"> +/- 0.025" max. within Pairs [Intra-pair] |
| <ul style="list-style-type: none"> Registered Clock from IOP Die to PLL Input with Respect to DQS | <ul style="list-style-type: none"> With-in +/- 1.0" of all strobes (DQS0-8) (strobe length measured from IOP die to SDRAM) |
| <ul style="list-style-type: none"> Registered Clock from IOP Die to PLL Input with Respect to Add/CMD/Control | <ul style="list-style-type: none"> 1.0" to 2.0" longer than Add/CMD/Control (Add/CMD/Control length measured from IOP die to Register input) |
| <ul style="list-style-type: none"> Un-buffered Clock from IOP Die to SDRAM input with respect to DQS | <ul style="list-style-type: none"> With-in +/- 1.0" of associated strobe (DQS) (strobe length measured from IOP die to SDRAM) |
| <ul style="list-style-type: none"> Un-buffered Clock from IOP Die to SDRAM input with respect to Add/CMD/Control | <ul style="list-style-type: none"> 1.0" to 2.0" longer than Add/CMD/Control from (Add/CMD/Control length measured from IOP die to SDRAM input) |
| <ul style="list-style-type: none"> Unbuffered Clock Pairs | <ul style="list-style-type: none"> +/- 0.1" max. between the 3 pairs of Unbuffered Clocks (clock length measured from IOP die to SDRAM) |
| Number of vias | <ul style="list-style-type: none"> For Registered: maximum of 3 pairs from IOP to PLL For Unbuffered: maximum of 4 pairs. |
| Routing Guideline | All un-buffered clocks utilized in memory implementations must be load balanced. Use capacitors equal to the SDRAM's clock input capacitance to balance loading across all the clocks used. Topology shown is based on a Raw B implementation. Refer to JEDEC Un-buffered DIMM specs. for Raw Card C implementation specifics. |

Table 49. Embedded DDR 333 Buffered Clock Topology Lengths

| Traces | Description | Layer | Min Length | Max Length | Trace Impedance | Spacing | Notes |
|--------------|-------------|--------------------------|------------|------------|--------------------------------------------|---------------------|----------------------|
| TL0 | Breakout | Microstrip/ Stripline | | 0.5" | | 5 mils | Differential Routing |
| TL1 | Lead-in | Microstrip/ Stripline | 2" | 8" | Differential Impedance of 100 ohms +/- 15% | 20 mils from others | |
| TL2 | Termination | | | 0.2" | | 5 mils | |
| TL0_PLL FB | | | 2" | 3" | Same as TL1 | 20 mils from others | Route per DDR1 JEDEC |
| TL2_PLL FB | Termination | | | 0.3" | | | Route per DDR1 JEDEC |
| TL3_PLL FB | | | 0.05" | 0.09" | Same as TL1 | | Route per DDR1 JEDEC |
| TL0_sdr m | | | 2.5" | | Same as TL1 | | Route per DDR1 JEDEC |
| TL1_sdr m | Termination | | 0.5" | 0.58" | | | Route per DDR1 JEDEC |
| TL2_sdr m | | | 0.29" | 0.3" | Same as TL1 | | Route per DDR1 JEDEC |
| TL0_reg | | | | 0.05" | | | Route per DDR1 JEDEC |
| TL1_reg | | | 2.71" | 2.72" | Same as TL1 | | Route per DDR1 JEDEC |
| TL2_reg | Termination | | 0.20" | 0.22" | | | Route per DDR1 JEDEC |

NOTES:

1. For any additional loading configurations use same recommendations of TL1_SDRAM and TL2_SDRAM values.
2. JEDEC DDR1 (PC2700) registered DIMM recommendations are referenced for post PLL configurations.

Figure 46. Embedded DDR 333 Unbuffered Clock Topology

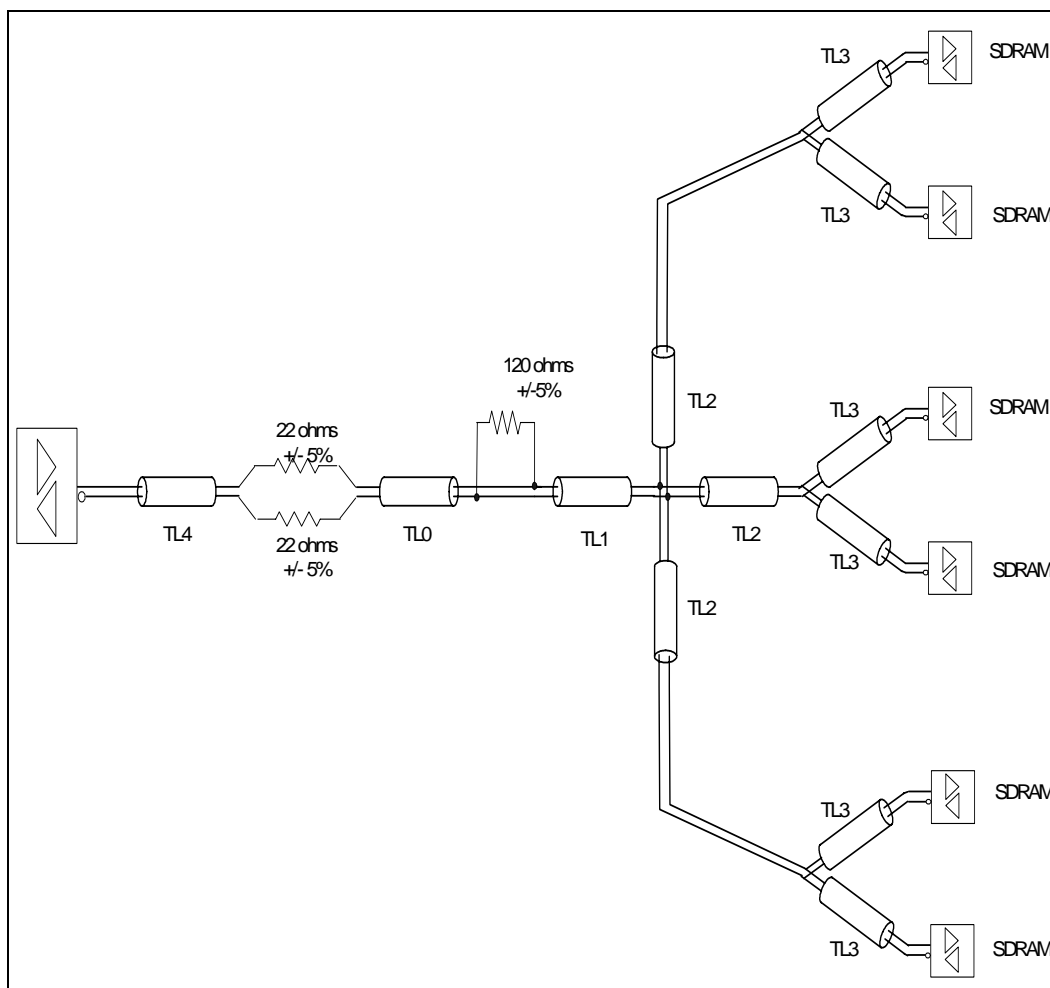

Table 50. Embedded DDR 333 Unbuffered Clock Topology Lengths

| Traces | Description | Layer | Minimum Length | Maximum Length | Trace Impedance | Spacing | Notes |
|--------|-------------|--------------------------|----------------|----------------|-------------------------------|--------------------------------|---------------------------------------------------------------------------------------------------------------------------------------------------------------------------------------------------------------------------------------------------------|
| TL0 | Lead-in | Microstrip/ Stripline | 2" | 10" | Differential 100 ohms +/- 15% | 20 mils from any other signals | <ul style="list-style-type: none"> Match within +/- 1" of strobes (DQS) from controller to SDRAM and within +/- 1" of Address/CMD control from controller to SDRAM input. Route as T Differential pairs as per DDR1 DIMM JEDEC. |
| TL1 | | | 0.47" | 0.49" | Same as TL0 | 20 mils | Route per DDR1 JEDEC |
| TL2 | | | 0.72 " | 0.73" | Same as TL0 | 20 mils | Route per DDR1 JEDEC |
| TL3 | | | 0.36 | 0.37" | Same as TL0 | 20 mils | Route per DDR1 JEDEC |
| TL4 | Breakout | Any | | 0.5" | | 5 mils | Route as differential |

7.4.3.3 DDR 333 Embedded Address/Command/Control Routing Guidelines

This section lists the recommendations for the DDR 333 embedded address/command/control signal routing (**RAS#**, **CAS#**, **WE#**, **BA[1:0]**, **MA[12:0]**, **CS[1:0]#**, and **CKE[1:0]**). Refer to [Table 51](#) and [Figure 47](#) for a block diagram of the lengths and matching requirements. [Table 52](#) provides the guidelines from the register to SDRAM.

Table 51. DDR 333 Embedded Address/Command Routing Recommendations (Sheet 1 of 2)

| Parameter | Routing Guideline |
|----------------------------------------------------|-----------------------------------------------------------------------------------------------------------------------------------------------------------------------------------------------------------------------------------------------------------------------------------------------------------------------|
| Reference Plane | Route over unbroken ground plane |
| Preferred Topology | <ul style="list-style-type: none"> • Micro-strip only for Un-buffered memory configurations • Either Micro-strip or Stripline for Registered memory implementations and lightly loaded Un-buffered memory implementations (i.e. single bank w/ less than or equal to 36pF input capacitance). |
| Microstrip Trace Width and spacing | 5 mils x 5 mils. Microstrip is recommended for pin escapes and terminations. |
| Trace Impedance | <ul style="list-style-type: none"> • 45 ohm +/- 15% or • 50 ohms +/- 15% |
| Trace Spacing (trace edge to edge) | <ul style="list-style-type: none"> • 5 mils is acceptable for pin escapes and terminations. • >12 mils within group • >20 mils must be maintained from any other groups (Clock/DQ/DQS) |
| Trace Length | Refer to following Embedded Addr/CMD Topology Table 52 for unbuffered and Table 53 for registered. |
| Series Resistor | 22 +/- 5% ohms unbuffered configurations only |
| Parallel Resistor | 51 +/- 5% ohms <ul style="list-style-type: none"> • Place the VTT terminations in VTT island after the DIMM (trace length of 0.15" to 0.5"0. • Split termination of 100 ohms +/- 5% to 2.5 V and 100 ohms +/- 5% to ground |
| Package Trace Length: Main Route Trace Lengths: | See Package Details for net length report Table 37 . Refer to respective following Un-buffered or Registered Topology/ Trace Length tables for more details. |

Table 51. DDR 333 Embedded Address/Command Routing Recommendations (Sheet 2 of 2)

| Parameter | Routing Guideline |
|---------------------|-------------------------------------------------------------------------------------------------------------------------------------------------------------------------------------------------------------------------------------------------------------------------------------------------------------------------------------------------------------------------------------------------------------------------------------------------------------------------------|
| Length Matching | <ul style="list-style-type: none"> • The package lengths from Die to Ball provided in Table 37 must be accounted for when length matching • For total capacitive loads greater than 36pF, all ADD/CMD/CTRL trace lengths must be 2.0" to 3.0" shorter than M_CK's trace length • For total capacitive loads less than or equal to 36pF, all ADD/CMD/CTRL trace lengths must be 1.0" to 2.0" shorter than M_CK's trace length |
| Number of vias | <ul style="list-style-type: none"> • For Un-buffered memory implementations: Maximum of 5 • For Registered memory implementations: Maximum of 5 from IOP die to register. Maximum of 6 from Register to SDRAM. |
| Routing Guideline 1 | Topology shown is based on a Raw B implementation. Refer to JEDEC Un-buffered DIMM specs. for Raw Card C implementation specifics. |

Table 52. Embedded DDR 333 Unbuffered Address/CMD Topology Lengths

| Traces | Description | Layer | Minimum Length | Maximum Length | Trace Impedance | Spacing | Notes |
|--------|-------------|--------------------------|----------------|----------------|---------------------------------------|---------|----------------------------------------------------------------------------|
| TL1 | | Microstrip/ Strip | 1.5" | 1.67" | 45 ohms+/-15% or 50 ohms +/-15% | 12 mils | TL1-TL6 as per JEDEC DDR1 Specifications (PC2700) to be routed as T points |
| TL2 | | Microstrip | 1.2 " | 1.35" | Same as TL1 | 12 mils | |
| TL3 | | Microstrip | 0.5" | 0.6" | Same as TL1 | 12 mils | Fan out for series termination (only for unbuffered) |
| TL4 | | | 0.3" | 0.35" | Same as TL1 | 12 mils | |
| TL5 | | | 0.14" | 0.18" | Same as TL1 | 12 mils | |
| TL6 | | | 0.32" | 0.35" | Same as TL1 | 12 mils | |
| TL7 | | | 0.25" | 0.5" | Same as TL1 | 12 mils | |
| TL8 | Breakout | Any | 0" | 0.5" | | 5 mils | |
| TL9 | Lead-in | Microstrip/ Stripline | 1" | 8" | 45 ohms+/-15% or 50 ohms +/-15% | 12 mils | Spacing: within the same group 12 mils With other groups 20 mils |
| TL10 | VTT | Microstrip | 0.25" | 0.5" | | 5 mils | Place in VTT Island |

NOTE: All traces except breakout TL8 traces are of the same impedance and spacing requirements.

Figure 47. Embedded DDR 333 Unbuffered ADDR/CMD Topology

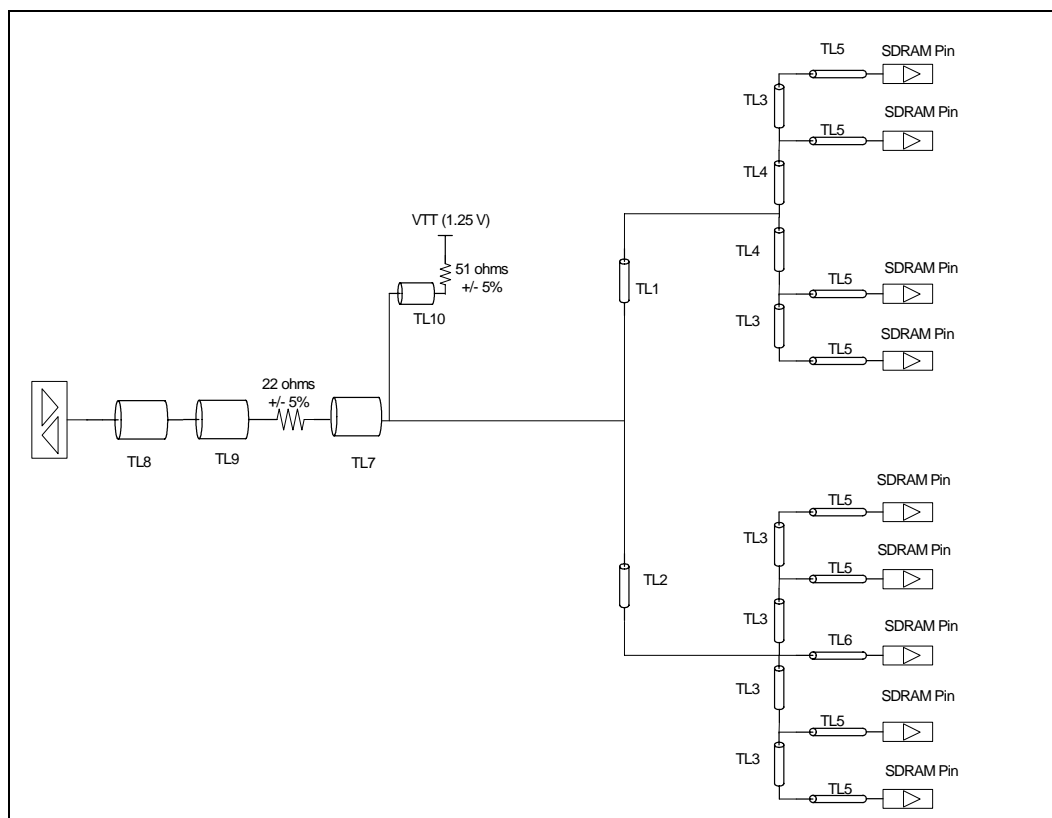

Table 53. Embedded DDR 333 Registered Address/CMD Topology Lengths

| Traces | Description | Layer | Minimum Length | Maximum Length | Trace Impedance | Spacing | Notes |
|--------|-------------|----------------------|----------------|----------------|---------------------------------------|---------|------------------------------------------------------------------------|
| TL1 | Breakout | Microstrip/ Strip | 0" | 0.5" | | 5 mils | 5 mils trace width for breakout |
| TL2 | | Microstrip | 0.6 " | 1.37" | 45 ohms+/-15% or 50 ohms +/-15% | 12 mils | Spacing: within the same group 12 mils Other groups 20 mils |
| TL3 | | | 1.39" | 2.57" | Same as TL2 | 12 mils | |
| TL4 | | | 0.4" | 0.56" | Same as TL2 | 12 mils | |
| TL5 | | | 0.14" | 0.15" | Same as TL2 | 12 mils | |
| TL6 | | | 0.48" | 0.63" | Same as TL2 | 12 mils | |
| TL7 | | | 0.20" | 0.32" | Same as TL2 | 12 mils | |
| TL8 | | | 0.49 | 0.72" | Same as TL2 | 12 mils | |
| TL9 | Lead-in | Microstrip | 1" | 9" | 45 ohms+/-15% or 50 ohms +/-15% | 12 mils | Spacing: within the same group 12 mils With other groups 20 mils |
| TL10 | | Microstrip | - | 0.2" | Same as TL2 | 12 mils | |
| TL11 | Vtt | Microstrip | 0.25' | 0.5" | | 5 mils | 5 mils trace width OK for breakout |

NOTES:

1. Post Register recommendations are referenced from JEDEC DDR1 Registered DIMM.
2. TL2 to TL8 are numbered JEDEC references.

Figure 48. Embedded DDR 333 Registered ADDR/CMD Topology

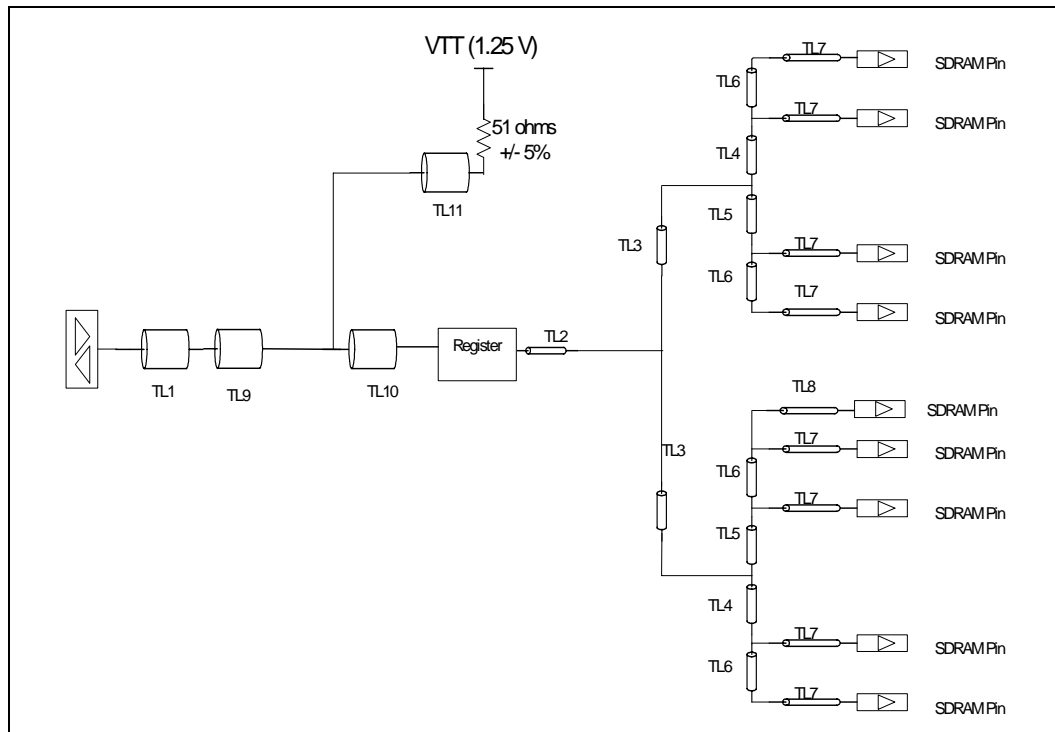

7.5 DDR II 400 Layout Guidelines

This section lists the DDRII layout guidelines for both DIMM and embedded designs. The topologies that were analyzed include registered DIMM (RawA and RawB configurations) and embedded single bank configurations (both ECC and Non-ECC type).

The On Die Termination or ODT for DDR II eliminates some of the termination resistors needed for the source synchronous signals. The value used for simulations was 75Ω. Note that this value must be programmed for both the IOP and the SDRAM locations.

The [Table 54](#) and [Table 55](#) list the DDR II differential strobe alignment with each of the DQ groups.

Table 54. x64 DDR Memory Configuration

| Data Group | Positive Strobe | Negative Strobe |
|------------------|-----------------|-----------------|
| DQ[7:0], DM[0] | DQS0 | DQS0# |
| DQ[15:8], DM[1] | DQS1 | DQS1# |
| DQ[23:16], DM[2] | DQS2 | DQS2# |
| DQ[31:24], DM[3] | DQS3 | DQS3# |
| DQ[39:32], DM[4] | DQS4 | DQS4# |
| DQ[47:40], DM[5] | DQS5 | DQS5# |
| DQ[55:48], DM[6] | DQS6 | DQS6# |
| DQ[63:56], DM[7] | DQS7 | DQS7# |

Table 55. x72 DDR Memory Configuration

| Data Group | Positive Strobe | Negative Strobe |
|-----------------------|-----------------|-----------------|
| DQ[7:0], DM[0] | DQS0 | DQS0# |
| DQ[15:8], DM[1] | DQS1 | DQS1# |
| DQ[23:16], DM[2] | DQS2 | DQS2# |
| DQ[31:24], DM[3] | DQS3 | DQS3# |
| DQ[39:32], DM[4] | DQS4 | DQS4# |
| DQ[47:40], DM[5] | DQS5 | DQS5# |
| DQ[55:48], DM[6] | DQS6 | DQS6# |
| DQ[63:56], DM[7] | DQS7 | DQS7# |
| CB[7:0], DM[8] | DQS8 | DQS8# |

7.5.1 Simulation Conditions

- Motherboard 50 ohm single ended impedance stackup +/- 15% tolerance
- Add-in Card 60 ohm single ended impedance stackup +/- 15% tolerance
- Clock Target Differential Impedance 100 ohms and 50 ohms single-ended impedance
- One Die Termination - ODT value of 75Ω was assumed for all DDR II simulations.
- Memory Model Micron U26 and Intel generic models
- PLL Clock - ICS ICSU877
- Register - IDT IDT74SSTU32864
- DIMM models and topologies used the JEDEC model as a reference.
- For unbuffered embedded and post PLL/register the JEDEC standard recommendations were used as a reference.
- Vias are modeled for all topologies with equal number of vias for differential pair
- Package - actual extracted package model.
- Spacing recommendations are for trace edge to edge except for differential pairs in which center to center was specified.
- Timing analysis was conducted.
- ISI Pattern was simulated for all the major topologies.
- Signal Quality analysis covered for Rising flight time, Falling flight time, Low to high ring-back (noise margin high), High to Low ring-back (noise margin Low), and Low and High Overshoot.
- Crosstalk Analysis was performed for all the major interfaces with actual package models.
- Frequency: 200MHz (DDR 400 MT/s)

The topologies simulated are listed in [Table 56](#).

Table 56. DDR II Topologies Simulated

| DIMM (Registered) | Embedded |
|-----------------------------------------------------------------------------------------------------------------|----------------------------------------------------------------------------------------------------------------------------------------------------------------------------------|
| 1. DQ/DQS <ul style="list-style-type: none"> • Read- RAW A, RAWB • Write -RAW A, RAW B | 1. DQ/DQS <ul style="list-style-type: none"> • Read- Single Bank • Write - Single Bank |
| 2. Clock <ul style="list-style-type: none"> • Buffered - controller to PLL • Unbuffered | 2. Clock <ul style="list-style-type: none"> • Controller to PLL • Post-PLL • PLL to SDRAM • PLL to Register • PLL to Feedback |
| 3. Address/CMD <ul style="list-style-type: none"> • Registered - RAWA, RAWB configurations | 3. Address/CMD <ul style="list-style-type: none"> • write single bank non ECC and ECC • Post Register - single bank ECC and non ECC |

7.5.2 DDRII-400 Trace Width/Impedance Requirements

The Table 57 below provides an example of a table of recommended topologies for motherboard and add-in card eight layer PCB designs. Throughout this section the important recommendation to meet is the trace impedance. The example in Table 57 is provided as a reference.

Table 57. Example Topology for DDRII Trace Width/Impedance Requirements

| Topology | Trace Width (mils) | Min Trace Spacing (mils) | Trace Impedance (ohms) | Preferred signals | Board Type |
|-----------------------------------|--------------------|--------------------------|------------------------|---------------------------|--------------------|
| Microstrip (layers 1 or 8) | 5 | 5 | | Breakout | Motherboard/Add-in |
| | 7 | 12 | 45 | Address/ CMD/Control | Motherboard/Add-in |
| | 6 | 12 | 50 | | Motherboard/Add-in |
| | 4 | 12 | 60 | | Motherboard/Add-in |
| | 5 (note 1) | 20 | 100 differential | Differential Clock/DQS | Motherboard/Add-in |
| Stripline (layers 3 or 6) | 5 | 5 | | Break out | Motherboard/Add-in |
| | 6 | 12 | 45 | DQ/CB | Motherboard |
| | 5 | 12 | 50 | | Add-in card |
| | 7 | 12 | 45 | DQ/CB | Add-in card |
| | 6 | 12 | 50 | | Add-in card |
| | 4 | 12 | 60 | | Add-in card |
| | 4 (note 2) | 20 | 100 Ohm | Differential Clock/DQs | Motherboard* |
| | 5 (note 3) | 20 | 100 Ohm | Differential Clock/DQs | Add-in card* |

NOTES:

1. Microstrip Differential Lines: Motherboard/Add-in 100 ohm: Constructed by two microstrips of 5 mils traces separated by center to center distance of 13 mils refer to [Figure 35](#).
2. Strip Differential Lines: Motherboard Stripline 100 ohms: Constructed by two striplines of 4 mils traces separated by center to center distance of 12 mils refer to [Figure 35](#).
3. Strip Differential Lines: Add-in stripline 100 ohms: Constructed by two striplines of 4 mils traces separated by center to center distance of 13 mils refer to [Figure 35](#).

7.5.3 DIMM Layout Design

The following tables provide the source synchronous, clock and control layout guidelines when laying out the board for DDRII 400 registered DIMMs. The guidelines were based on simulating RawA and RawB DIMM topologies.

7.5.3.1 DDR II 400 DIMM Source Synchronous Routing

This section lists the recommendations for the DDR II 400 Source Synchronous Routing. These signals include all the DQ/DQS/DM signals. Refer to [Figure 49](#) and [Table 58](#) for a block diagram of the lengths and matching requirements.

Figure 49. Intel® 80331 I/O Processor DDRII 400 DIMM Source Synchronous Routing

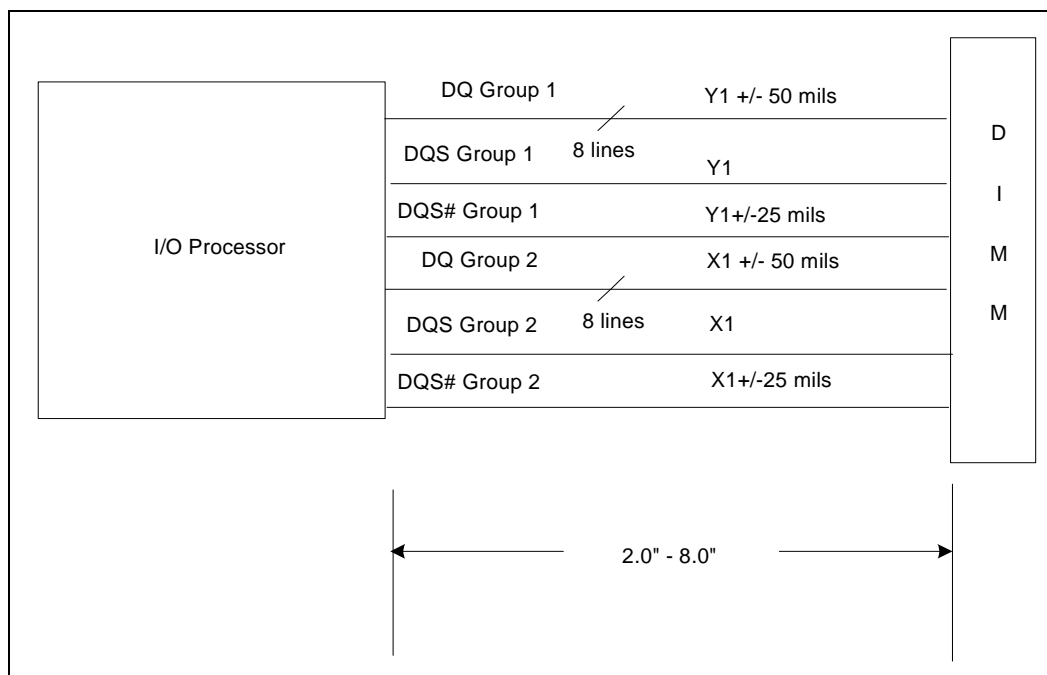

Table 58. DDRII 400 DIMM Source Synchronous Routing Recommendations

| Parameter | Routing Guideline |
|----------------------------------------------------------------------------------------------------------------------------------------------------------------------------------------------------------------------|------------------------------------------------------------------------------------------------------------------------------------------------------------------------------------------------------|
| Reference Plane Layer | Route over unbroken ground plane Strip line (layer 3 or layer 6) |
| Breakout | 5 mils on 5 mils spacing. Maximum length of breakout region can be up to 500 mils either microstrip or strip line |
| Stripline Trace Impedance Motherboard/Add-in Card Differential DQ | <ul style="list-style-type: none"> DQ signals: Single ended strip lines at 45 ohm +/-15% or 50 ohms +/- 15% impedance. Refer Table 57 and DIMM DQ topologies. |
| Stripline Trace Impedance Motherboard/Add-in Card Differential DQS | <ul style="list-style-type: none"> DQS Signals: Differential ended strip lines at 100ohm impedance. Refer to Table 57 and DIMM DQS Topologies. |
| DQ Group Spacing (edge to edge) | <ul style="list-style-type: none"> Spacing same group: 12 mils minimum Spacing from other DQ groups 20 mils minimum For DQS from any other signals: 20 mils minimum |
| Overall Trace Length: 80331 signal Ball to DIMM connector (no series connector) | 2" minimum to 8" maximum (correlated with the clock length from ball to DIMM). |
| DQS Length Matching: <ul style="list-style-type: none"> Trace Length Matching within DQS group Within one DQS pair plus and minus All DQ/DQS lines with respect to the clock signal | <ul style="list-style-type: none"> +/-0.05" within DQS group +/- 0.0250" +/- 1" (target motherboard clock = +/- 1" of any DQ/DQS pair) |
| Number of Vias | Two (for differential signals the number of vias on + and - signals must be the same) |
| Routing Guideline | Route all data signals and their associated strobes on the same layer. |

Table 59. DDR II 400 DIMM DQ Lengths

| Traces | Description | Layer | Minimum Length | Maximum Length | Trace Impedance | Spacing (edge to edge) | Notes |
|--------|-------------|------------|----------------|----------------|--------------------|--------------------------------------------|-------------------------------------|
| TL0 | Breakout | Microstrip | 0" | 0.5" | | 5 mils | 5 mils trace width OK for breakout. |
| TL1 | Lead-in | Microstrip | 2 " | 8" | 45 ohms or 50 ohms | Same group 12 mils Other groups 20 mils | |

Figure 50. DDR II 400 DIMM DQ Topology

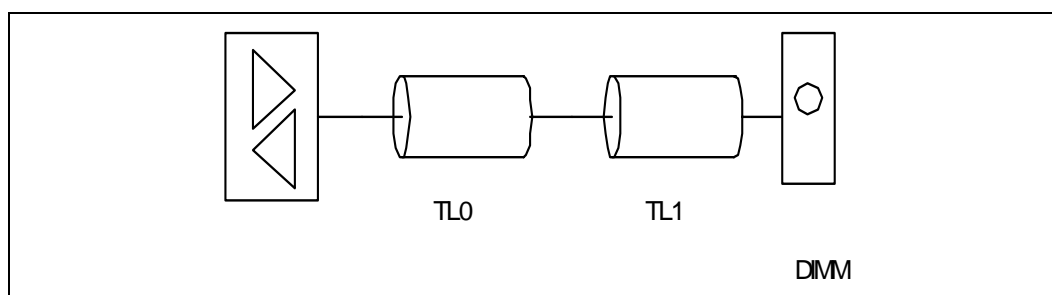
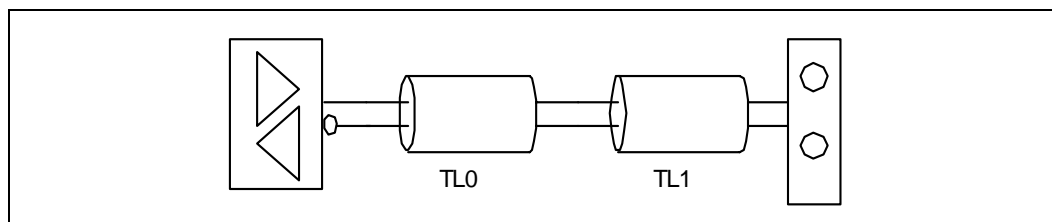

Table 60. DDR II 400 DIMM DQS Lengths

| Traces | Description | Layer | Minimum Length | Maximum Length | Trace Impedance | Spacing (edge to edge) | Notes |
|--------|-------------|------------|----------------|----------------|--------------------------------|----------------------------|----------------------------------------------------------------------------------------------------------------------------------------------------------------------------------------------------------------------------------------------------------------------------------------------------------------------------------------------------------|
| TL0 | Breakout | Microstrip | 0" | 0.5" | | 5 mils | 5 mils trace width OK for breakout. |
| TL1 | Lead-in | Microstrip | 2 " | 8" | Differential 100 ohm impedance | 20 mils from other signals | Route as differential pair. <ul style="list-style-type: none"> Motherboard 100 ohm differential constructed by stripline of two 4 mil traces separated by center to center distance of 12 mils. Add-in card 100 ohm differential constructed by stripline of two 5 mil traces separated by center to center distance of 12 mils. |

Figure 51. DDR II 400 DIMM DQS Topology



7.5.3.2 DDRII 400 Clock Routing Guidelines

This section lists the recommendations for the DDR II 400 Clock signals. Refer to [Figure 52](#) and [Table 61](#) for a description of the segment lengths and matching requirements.

Table 61. DDRII 400 DIMM Clock Routing Recommendations

| Parameter | Routing Guideline |
|-------------------------------------------------------------------------------------------------------------------------------------------------------------------------------------------------------------------------------------------------------------------------|------------------------------------------------------------------------------------------------------------------------------------|
| Reference Plane | Unbroken Ground plane |
| Preferred Topology | Microstrip differential lines (preferred) Stripline differential lines |
| Microstrip Trace Width and spacing | 5 mils by 5 mils. |
| Trace Impedance | Differential impedance of 100 ohms +/- 15% Refer to DIMM Clock Topology |
| Trace Spacing | > 20 mils between other signals. |
| Trace Length 1:80331signal Ball to DIMM connector | 2.0"min to 10.0" max correlated within the +/- 1.0" of the DQ/DQS and command signal length (from 80331 to DIMM connector). |
| Length Matching: <ul style="list-style-type: none"> • Within differential clock signals • With respect to DQ/DQS group (from controller to DIMM connector) • With respect to address/command group (from controller to DIMM connector) | +/- 0.0250" within pairs (intra-pair) +/- 1.0" maximum +/- 1.0" maximum |
| Routing Guideline 1 | Maximum of 1 via/layer change for differential clocks. (use the same number of vias between + and - signals of differential clock) |
| Routing Guideline 2 | Route clock signal as differential pair with target differential impedance of 100 ohms. |

Table 62. DDR II 400 DIMM Clock Lengths

| Traces | Description | Layer | Minimum Length | Maximum Length | Trace Impedance | Spacing (edge to edge) | Notes |
|--------|-------------|-------------------------|----------------|----------------|------------------------------------|------------------------|---------------------------------------------------------------------------------------------------------------------------------------------------------------------|
| TL0 | Breakout | Microstrip or stripline | 0" | 0.5" | | 5 mils | 5 mils trace width OK for breakout. |
| TL1 | Lead-in | Microstrip or stripline | 2 " | 10" | Differential Impedance of 100 ohms | Other groups 20 mils | Route as differential pair with target impedance of 100 ohms correlated within the +/- 1.0" of the DQ/DQS and command signal length (from 80331 to DIMM connector). |

Figure 52. DDR II 400 DIMM Clock Topology

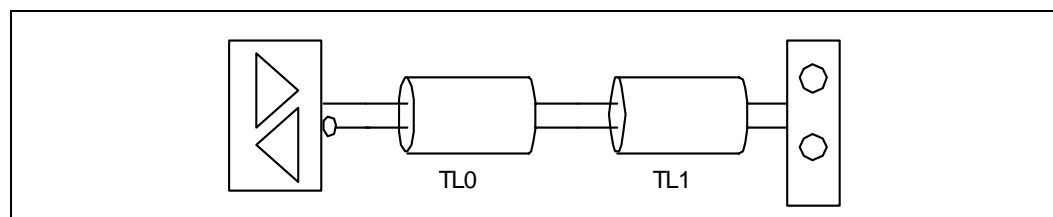

7.5.3.3 DDRII 400 Address/Command/Control Routing Guidelines

This section lists the recommendations for the DDR II 400 Address/Command and Control signals (**RAS#**, **CAS#**, **WE#**, **BA[1:0]**, **MA[12:0]**, **CS[1:0]#**, and **CKE[1:0]**). Refer to [Figure 53](#) and [Table 63](#) for a description of the segment lengths and matching requirements.

Table 63. DDRII 400 DIMM Address/Command/Control Routing Recommendation

| Parameter | Routing Guideline |
|-----------------------------------------------------------------------|-----------------------------------------------------------------------------------------------------------------------------------------------------------------------------------------------------------------|
| Reference Plane | Route over unbroken power plane |
| Preferred Topology | Microstrip lines |
| Breakout Trace Width and spacing | 5 mils x 5mils. |
| Trace Spacing | <ul style="list-style-type: none"> • 5 mils acceptable between the pins and the breakout regions. • >12 mils within group • >20 mils from any other clock/DQ/DQS groups. |
| Trace Impedance | 45 ohms +/- 15% or 50 ohms +/- 15% |
| Trace Length: Overall length from 80331 signal Ball to DIMM Connector | 2.0"min to 10" max (Correlated with in +/- 1" of DQ/DQS and command lead-in MB length) Refer to following table for segment lengths. |
| Length Matching Requirements: | 2"-10" matched within +/- 1" of target motherboard M_CK |
| Single Parallel Termination | 51 ohms +/- 5% to VTT |
| Split Termination | 100 ohms +/- 5% to ground and 100 ohms to 1.8V |
| Routing Guideline 1 | Route clock signal as differential pair with target differential impedance of 100 ohms |
| Routing Guideline 2 | Place the VTT terminations in the VTT island after the DIMM with a trace length of 0.15" to 0.5" |
| Routing Guideline 3 | For split terminations place the VTT termination in their respective power islands |
| Number of vias | 2 Vias or less |

Table 64. DDR II 400 DIMM Address/CMD Lengths

| Traces | Description | Layer | Minimum Length | Maximum Length | Trace Impedance | Spacing | Notes |
|--------|-------------|------------|----------------|----------------|--------------------|---------|--------------------------------------------------------------------------------------------------------------------------------------------------------------|
| TL0 | Breakout | Microstrip | 0" | 0.5" | | 5 mils | 5 mils trace width OK for breakout. |
| TL1 | Lead-in | Microstrip | 2 " | 10" | 45 ohms or 50 ohms | 12 mils | <ul style="list-style-type: none"> 45 ohm +/- 15% or 50 ohm +/- 15% 2"-10" matched within +/- 1" of target motherboard M_CK |
| TL2 | Vtt | Microstrip | 0.15 " | 0.5" | | 5 mils | Place terminations in Vtt island |

Figure 53. DDR II 400 DIMM Address/CMD Topology

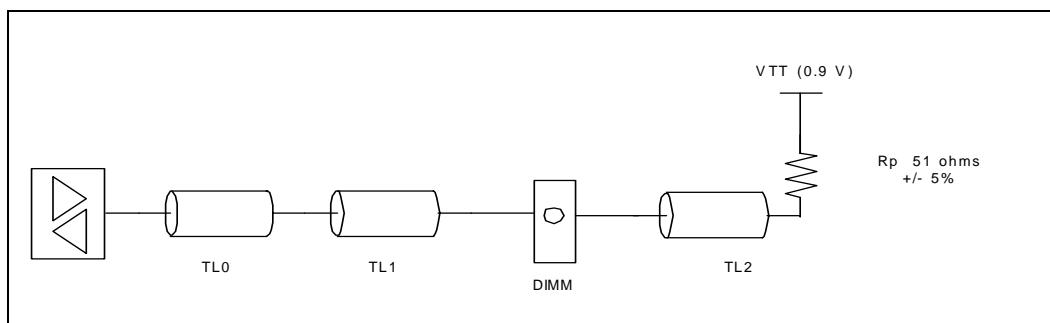
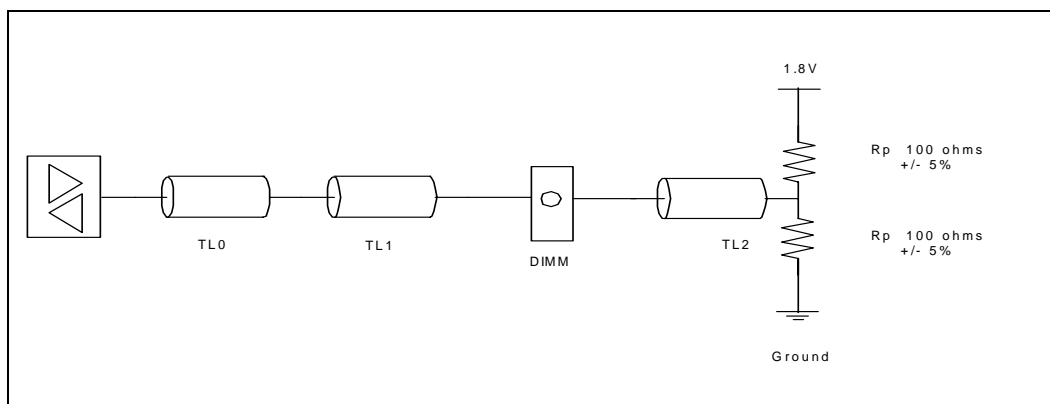

Figure 54. DDR II 400 DIMM Address/CMD Split Termination Topology



7.5.4 Embedded Configuration

The following tables provide layout guidelines for applications in which the DDRII 400 memory SDRAM, registers and PLL components are placed directly on the board without a DIMM.

7.5.4.1 DDRII 400 Embedded Source Synchronous Routine Guidelines

This section lists the recommendations for the DDR II 400 embedded source synchronous routing. These signals include all the DQ/DQS signals. Refer to [Table 65](#) and [Figure 55](#) for a block diagram of the lengths and matching requirements.

Table 65. DDRII 400 Embedded Source Synchronous Routing Recommendations

| Parameter | Routing Guideline |
|-----------------------------------------------------------------------------------------------------------------------------------------------------------------------------------------------------------------------------------------------|-------------------------------------------------------------------------------------------------------------------------------------------------------------------------------------------------------------------------------------------------------------------------------------------------------------------------------------------------------------------------------------------------------------------------------------------------------------------------------------------------------------------------------------------------------------------------------------------------------------------------------------------|
| Reference Plane | Route over unbroken power plane |
| Preferred Topology | Stripline |
| Breakout | 5 mils x 5 mils spacing. |
| Group Trace Spacing (edge to edge) | <ul style="list-style-type: none"> • 5 mils is acceptable for pin escapes and terminations. • 5 mils for DQS differential pairs (intra-pair) • >12 mils between any DQ/DQS signals • >20 mils must be maintained from any other groups |
| Trace Impedance | <ul style="list-style-type: none"> • 45 ohms +/- 15% • 50 ohms +/- 15% • Differential impedance of 100 ohms +/- 15% |
| Trace Details | <ul style="list-style-type: none"> • TL1 and TL4 are approximately same length and the series Termination to be placed in the middle of lead-in trace for Lead-in lengths >6 Inches • When Controller to SDRAM lead-in trace length is less than 6 Inches, Series Termination may be placed anywhere between middle of the lead-in trace to SDRAM • For DQS use differential routing • Route all data signals and associated strobes on same layer as strip lines. • No parallel DQS termination is required with ODT of SDRAMs used. • Refer to Figure 55 |
| DQ Group Spacing | Spacing from other DQ groups 20 mils minimum |
| Trace Lengths | Refer to Figure 55 for details. |
| DQS Length Matching: <ul style="list-style-type: none"> • Trace Length Matching within DQS group • Within one DQS pair plus and minus • Between other DQS groups • With respect to the clock signal | <ul style="list-style-type: none"> +/- 0.05" within DQS group +/- 0.0250" +/- 0.250" between each of the DQS groups. +/- 1" (target motherboard clock to PLL input = +/- 1" of any DQS/DQ pair) |
| Series Termination | 22.1 ohms +/- 5% |
| Parallel Termination | No parallel DQS termination is required with ODT of SDRAMs used. |
| Routing Guideline 1 | Route all data signals and associated strobes on same layer. |
| Routing Guideline 2 | Minimize layer changes especially on clock and DQS signals. (two vias or less) |

Table 66. DDR II 400 Embedded DQ Lengths

| Traces | Description | Layer | Minimum Length | Maximum Length | Trace Impedance | Spacing | Notes |
|--------|-------------|------------|----------------|----------------|--------------------|---------|-----------------------------------------------|
| TL0 | Breakout | Microstrip | 0" | 0.5" | | 5 mils | 5 mils trace width OK for breakout. |
| TL1 | Lead-in* | Stripline | 1 " | 4" | 45 ohms or 50 ohms | 12 mils | 45 ohms +/- 15% 50 ohms +/- 15% |
| TL2 | | Microstrip | 0" | 0.1" | | 5 mils | 5 mils trace width OK for termination fan out |
| TL3 | | Microstrip | 0" | 0.1" | | 5 mils | 5 mils trace width OK for termination fan out |
| TL4 | Same as TL1 | Stripline | 1" | 4" | 45 ohms or 50 ohms | 12 mils | 45 ohms +/- 15% 50 ohms +/- 15% |

NOTES:

1. TL1 and TL4 are approximately the same length allowing Rs in the middle of the lead-in trace between the controller and SDRAM.
2. Then controller to SDRAM lead-in traces are less than 6" the series resistor may be places anywhere in between the center of the lead-in trace to SDRAM

Figure 55. DDR II 400 Embedded DQ Topology

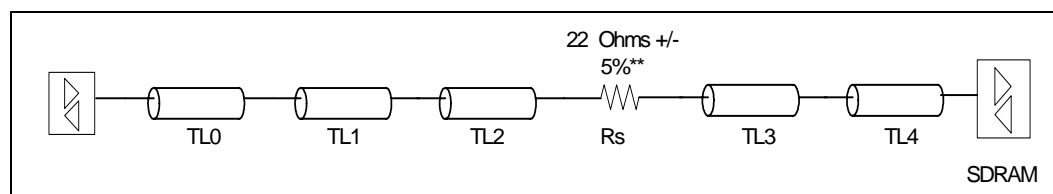

Table 67. DDR II 400 Embedded DQS Lengths

| Traces | Description | Layer | Minimum Length | Maximum Length | Trace Impedance | Spacing | Notes |
|--------|-------------|------------|----------------|----------------|-------------------------------------------|---------------------|-----------------------------------------------|
| TL0 | Breakout | Microstrip | 0" | 0.5" | | 5 mils | 5 mils trace width OK for breakout. |
| TL1 | Lead-in | Stripline | 1 " | 4" | Differential impedance of 100 ohms +/-15% | 20 mils from others | |
| TL2 | | Microstrip | 0" | 0.1" | | | 5 mils trace width OK for termination fan out |
| TL3 | | Microstrip | 0" | 0.1" | | | Same as TL2 |
| TL4 | Same as TL1 | Stripline | 1 in | 4" | Differential impedance of 100 ohms +/-15% | 20 mils from others | Same as TL1 |

NOTES:

1. TL1 and TL4 are approximately the same length allowing R_s in the middle of the lead-in trace between the controller and SDRAM.
2. When controller to SDRAM lead-in traces are less than 6" the series resistor may be placed anywhere in between the center of the lead-in trace to SDRAM.

Figure 56. DDR II 400 Embedded DQS Topology

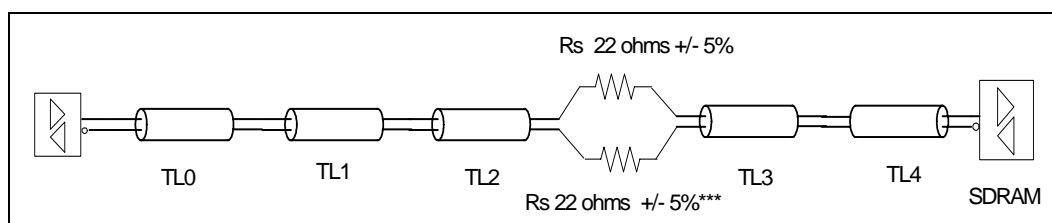

7.5.4.2 DDRII 400 Embedded Clock Routing Recommendations

This section lists the recommendations for the DDR II 400 clock signals. Refer to [Figure 57](#) and [Table 68](#) for a description of the segment lengths and matching requirements [Table 69](#) provides the guidelines from PLL to SDRAM.

Table 68. DDRII 400 Embedded Clock Routing Recommendations

| Parameter | Routing Guideline |
|------------------------------------------------------------------------------------------------------------|--------------------------------------------------------------------------------------------------------------------------------------------------------------------------------------------------------------------------------------------------------------------------|
| Reference Plane | Route over unbroken ground plane |
| Preferred Topology | Microstrip or Stripline routed differentially |
| Breakout Trace Width and Spacing | 5 mils x 5 mils. |
| Trace Spacing | <ul style="list-style-type: none"> • 5 mil spacing acceptable between pin escapes and breakout regions. • 5 mils for clock differential pairs (intra-pair), • >20 mils between other signals. |
| Trace Impedance | Differential impedance of 100 ohms +/- 15% Refer to Figure 57 |
| Trace Details | Route as differential pair with differential impedance of 100 ohms. Figure 57 |
| Overall Trace Length | 2.0"min to 10.0" max; refer to figures and tables that follow for line segment lengths and topology. |
| DQS Length Matching: <ul style="list-style-type: none"> • Within differential clock signals | +/- 0.0250" within pairs (intra-pair) |
| Overall clock correlation with other signals | <ul style="list-style-type: none"> • All DQ/DQS groups matching needs to be matched within +/- 1" of the clock signals. • Address/Command/Control lengths from 80331 ball to the register needs to be matched within +/- 1" of the clock signals |
| Series Termination | No series termination for buffered memory |
| Parallel Termination | 100 ohms |
| Routing Guideline 1 | Maximum of 2 via/layer change for differential clocks. |
| Routing Guideline 2 | Route clock signal as differential pair with target differential impedance of 100 ohms and single ended impedance of 50 ohms with ground referenced strip line only. |

Table 69. DDR II 400 Embedded Clock (PLL) Lengths

| Traces | Description | Layer | Minimum Length | Maximum Length | Trace Impedance | Spacing | Notes |
|------------|-----------------|-------------------------|----------------|----------------|--------------------------------------------|---------------------|-------------------------------------------------------------------------------------------------------------|
| TL0 | Breakout | Any | 0" | 0.5" | | 5 mils | 5 mils trace width OK for breakout. |
| TL1 | Lead-in | Microstrip/Stripline | 2 " | 10" | Differential impedance of 100 ohms +/- 15% | 20 mils from others | <ul style="list-style-type: none"> Route as differential pair. Refer to table __ for details |
| TL2 | For Termination | Microstrip | 0" | .1" | | 5 mils | |
| TL0_PLLFB | PLL Feedback | Microstrip or stripline | 2.2 " | 2.3" | Same as TL1 | 20 mils | Route as per DDRII JEDEC |
| TL1_PLLFB | | Microstrip or stripline | 20 mils | 50 mils | | 20 mils | Route as per DDRII JEDEC |
| TL2_PLLFB | For Termination | Microstrip or stripline | 0" | 100 mils | | 5 mils | Route as per DDRII JEDEC |
| TL0_s dram | | Microstrip/Stripline | 2.7" | 2.75" | Same as TL1 | 20 mils from others | Route as per DDRII JEDEC |
| TL1_s dram | | Microstrip/Stripline | 0.5" | 0.75" | | 20 mils from others | Route as per DDRII JEDEC |
| TL2_s dram | For Termination | Microstrip/Stripline | 0" | 150mils | | 5 mils | |
| TL0_reg | | Microstrip/Stripline | 2" | 2.25" | Same as TL1 | 20 mils | Route as per DDRII JEDEC |
| TL1_reg | | Microstrip/Stripline | 25 mils | 50mils | | 20 mils | Route as per DDRII JEDEC |
| TL2_reg | For Termination | Microstrip/Stripline | 100 mils | 125 mils | | 5 mils | |

Figure 57. DDR II 400 Embedded Clock Topology

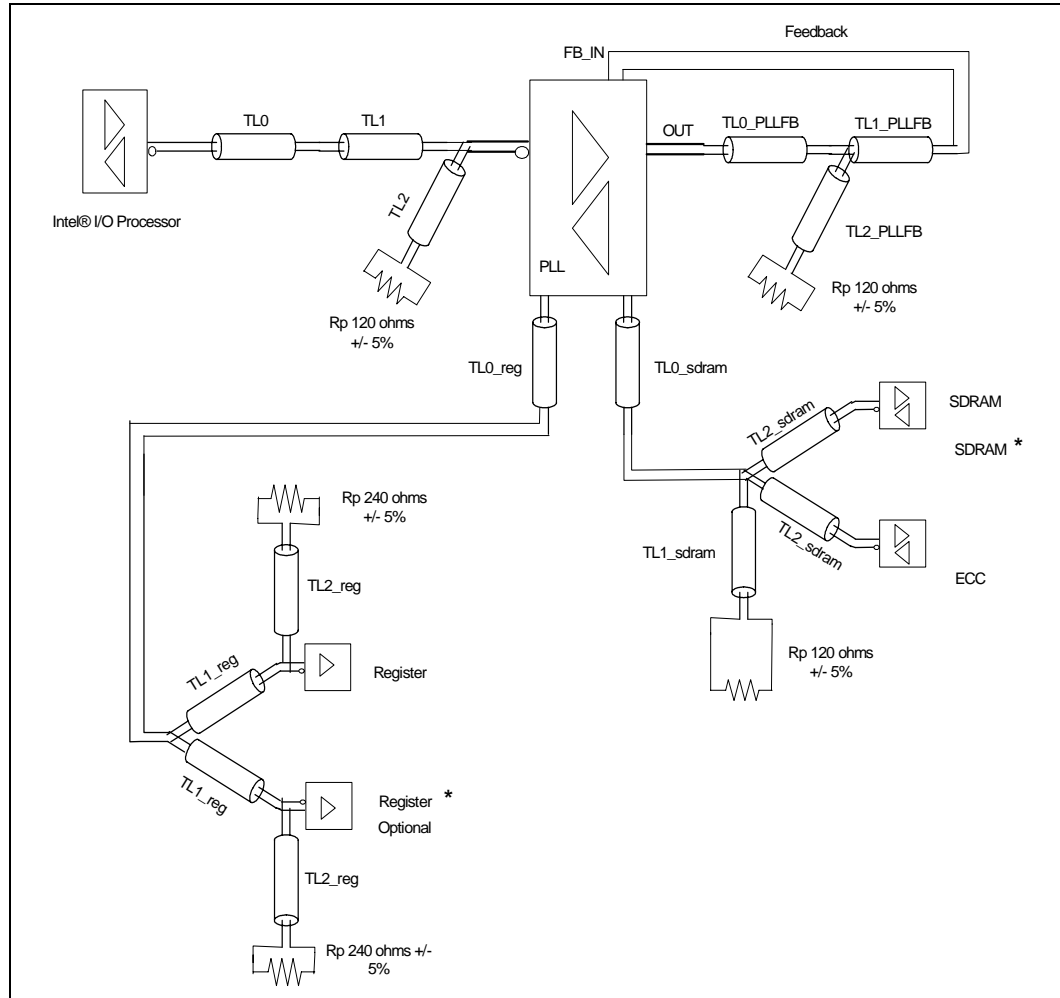

7.5.4.3 DDRII 400 Embedded Address/Command/Control Routing Guidelines

This section lists the recommendations for the DDR II 400 embedded address/command/control signal routing. Refer to Table 70, Table 71, Figure 58 and Figure 59 for a block diagram of the lengths and matching requirements.

Table 70. DDRII 400 Embedded Address/Command/Control Routing Recommendations

| Parameter | Routing Guideline |
|----------------------------------------------------|--------------------------------------------------------------------------------------------------------------------------------------------------------------------------------------------------------------------------------------------------------------------------------------------------------------------------------------------------------------------------------------------------------------------------------------------------------------------------------------------------------------------------------------|
| Reference Plane | Route over unbroken ground plane |
| Preferred Topology | Microstrip (outer layers) preferred or Stripline (inner layers) |
| Microstrip Trace Width and Spacing | 5 mils x 5 mils. Microstrip is recommended only for pin escapes and terminations. |
| Trace Impedance | 45 ohms +/- 15% or 50 ohms +/- 15% Refer to Embedded Address/CMD topology |
| Microstrip Trace Spacing (edge to edge) | <ul style="list-style-type: none"> • 5 mils acceptable through pin field, break out regions and terminations • >12 mils within group • >20 mils from any other clock/DQ/DQS groups. |
| Overall length 80331 signal Ball to register input | 2" minimum - 10" maximum length matched within +/- 1.0" of target motherboard clock M_CK to PLL. |
| Series Termination | none |
| Parallel Termination | <ul style="list-style-type: none"> • 51 ohms, place the VTT terminations in the VTT island after TL1 by trace length of TL10 • or Split Termination of 100Ohms to 1.8V and 100 Ohms to Ground can be used • Place the VTT Terminations in VTT Island after TL1 by Trace Length of TL10 (Single VTT Termination) • Place Split terminations in respective Voltage rails island. • Refer to Embedded Address/CMD Topology and Table for Single VTT Termination or Split Termination |
| Routing Guideline 1 | Post register TL2-TL8 route as per JEDEC DDRII Registered DIMM T routing. |
| Routing Guideline 2 | 3 Vias or less for preregister, route as per T routing requirement for post register. |

Table 71. DDR II 400 Embedded Address/CMD Lengths

| Traces | Description | Layer | Minimum Length | Maximum Length | Trace Impedance | Spacing | Notes |
|--------|--------------------------------------|-----------------|----------------|----------------|--------------------|---------|-----------------------------------------------------------------------------------------------|
| TL0 | Breakout | Any | 0" | 0.5" | | 5 mils | 5 mils trace width OK for breakout. |
| TL1 | Lead-in | Microstrip | 2 " | 10" | 45 ohms or 50 ohms | 12 mils | <ul style="list-style-type: none"> 45 ohms +/- 15% or 50 ohms +/- 15% |
| TL2 | | Microstrip (MS) | 20 mils | 25 mils | Same as TL1 | 12 mils | TL2 to TL8 as per JEDEC DDRII Registered specification routed as T points |
| TL3 | | MS | 1500 mils | 1550 mils | Same as TL1 | 12 mils | |
| TL4 | | MS | 1850 | 1900 | Same as TL1 | 12 mils | |
| TL5 | | MS | 500 | 560 | Same as TL1 | 12 mils | |
| TL6 | | MS | 275 | 325 | Same as TL1 | 12 mils | |
| TL7 | | MS | 550 | 600 | Same as TL1 | 12 mils | |
| TL8 | | MS | 50 | 270 | Same as TL1 | 12 mils | |
| TL9 | Fan out | MS | 0" | 100 | | 5 mils | |
| TL10 | VTT Termination or split termination | MS | 150 | 500 | | 5 mils | To be placed in respective VTT power island. |

Figure 58. DDR II 400 Embedded Address/Control Topology

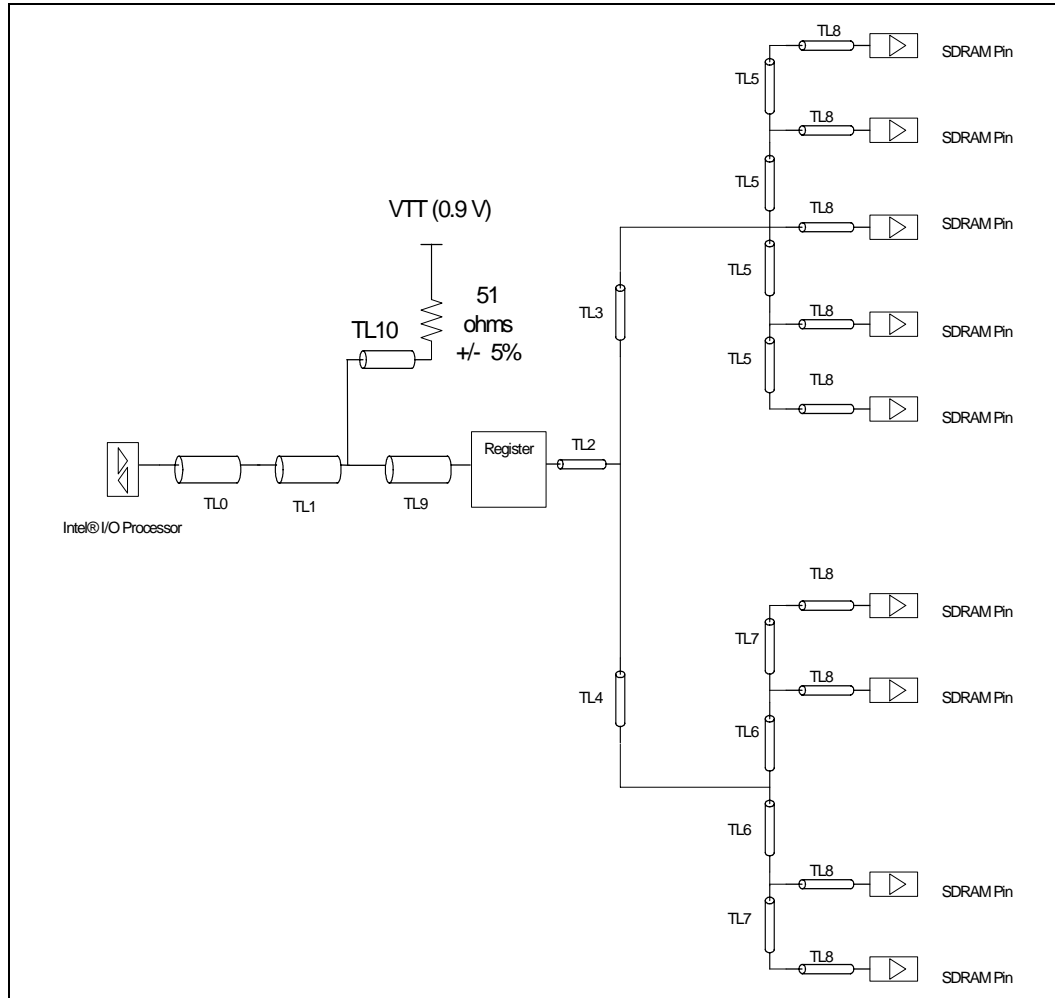
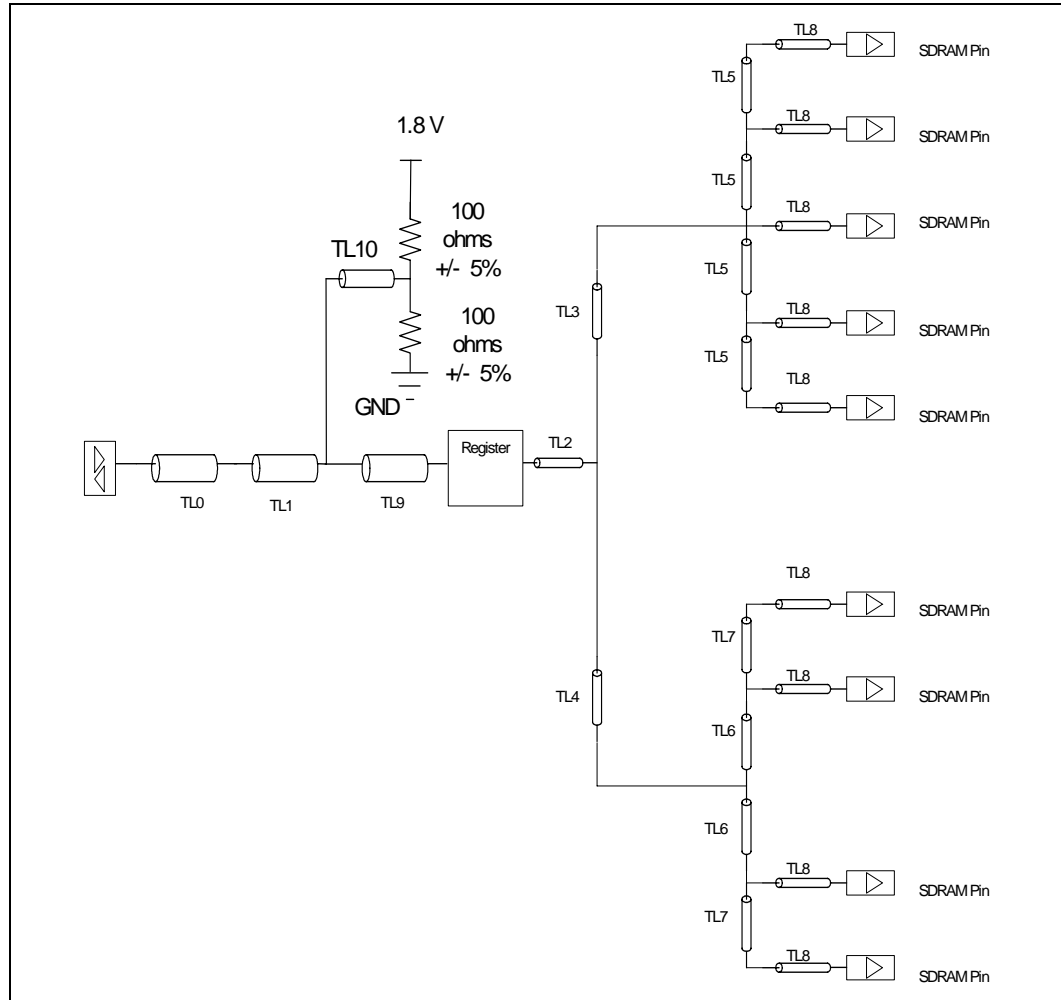

Figure 59. DDR II 400 Embedded Address/Control Topology With Split Termination



7.6 DDR Signal Termination

This section provides suggested guidelines for layout of the DDR termination resistors:

- Place a 1.25 V termination plane for DDR or a 0.9V termination plane for DDR II 400 on the top layer or one of the inner layers, just beyond the DIMM connector for DDR.
- The V_{TT} island must be at least 50 mils wide.
- Use this termination plane to terminate all DIMM signals, using the one termination resistor per signal.
- Decouple the V_{TT} plane using one 0.1 μ F decoupling capacitor per two termination resistors.
- Each decoupling capacitor must have at least two vias between the top layer ground fill and the internal ground plane.
- In addition, place one 10 μ F or larger (100 μ F suggested) Tantalum capacitor on each end of the termination island for bulk decoupling.
- Figure 60 provides an example of how to route the termination resistors.

Figure 60. Routing Termination Resistors (top view)

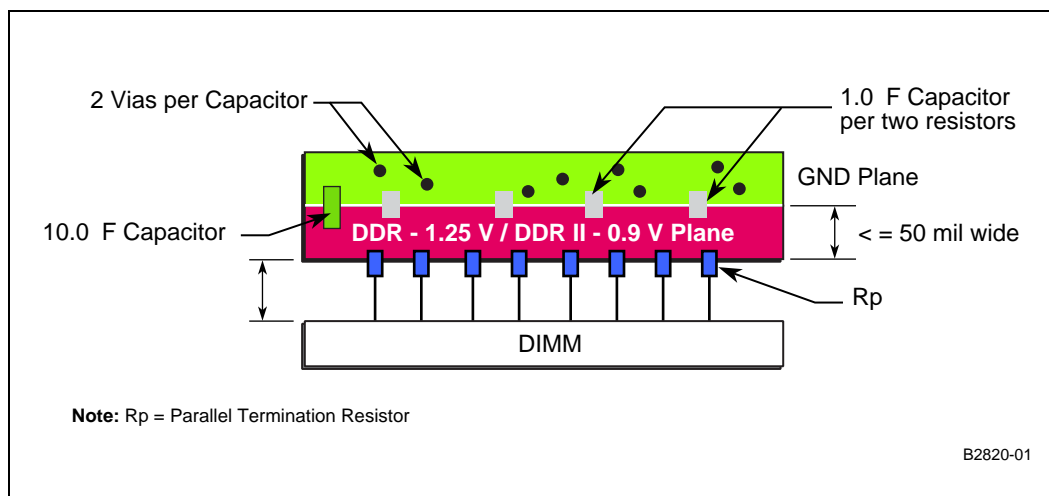

7.7 DDR Termination Voltage

The V_{TT} DDR termination voltage must track the V_{DDQ} and provide the termination voltage to the termination resistors. This tracking must be 50 percent of ($V_{DDQ} - V_{SSQ}$) over voltage, temperature, and noise. It must maintain less than 40 mV offset from V_{REF} over these conditions. This voltage must be low-impedance and source-significant current. The source and sink DC current for signal termination is at its absolute maximum current of 2.6 A-2.9 A for a 64/72-bit DIMM.

7.8 DDR V_{REF} Voltage

The Figure 61 shows the DDR V_{ref} voltage. The DDR V_{REF} is a low-current source (supplying input leakage and small transients). It must track 50 percent of ($V_{DDQ} - V_{SSQ}$) over voltage, temperature, and noise. Use a single source for V_{REF} to eliminate variation and tracking of multiple generators. Maintain 15-20 mils clearance around other nets. Use a distributed decoupling scheme. Use a simple resistor divider with 1% or better accuracy.

Note: The 100 ohm resistors can be replaced with 1K +/- 1% resistors to minimize leakage current during battery backup mode.

Figure 61. DDR V_{REF} Circuit

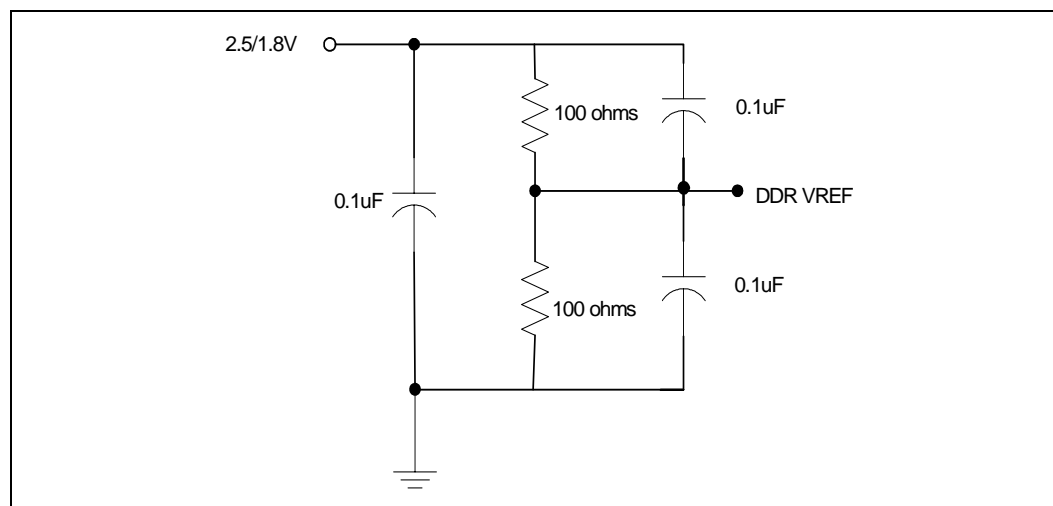



Peripheral Local Bus

8

The Peripheral Bus Interface Unit (PBI) is a data communication path to Flash memory components and peripherals of a 80331 hardware system. The PBI allows the processor to read and write data to these supported flash components and other peripherals. To perform these tasks at high bandwidth, the bus features a burst transfer capability which allows successive 8- or 16-bit data transfers.

The peripheral bus is controlled by the on-chip bus masters: the Intel XScale® core, the ATU, AAU and DMA units.

The address/data path is multiplexed for economy, and the bus width is programmable to 8-, and 16-bit widths. The PBI performs the necessary packing and unpacking of bytes to communicate properly across the 80331 Internal Bus.

The PBI unit includes two chip enables. The PBI chip enables activate the appropriate peripheral device when the address falls within one of the PBI's two programmable address ranges. Both address ranges incorporate functionality that optimizes an interface for Flash Memory devices.

8.1 Peripheral Bus Signals

Bus signals consist of two groups: address/data, and control/status.

8.1.1 Address/Data Signal Definitions

The address/data signal group consists of 26 lines. 16 of these signals multiplex within the processor to serve a dual purpose. During an address cycle (T_A), the processor drives $A[22:16]$ and $AD[15:0]$ with the address of the bus access. At all other times, the $AD[15:0]$ lines are defined to contain data. $A[2:0]$ are demultiplexed address pins providing incrementing byte addresses during burst cycles.

8.1.2 Control/Status Signal Definitions

The control/status signals control peripheral device enables and direction. All output control/status signals are three-state.

The PBI pulses **ALE** (address latch enable) active high for one clock during T_A to latch the multiplexed address on $AD[15:2]$ in external address latches.

A peripheral read may be either non-burst or burst. A non-burst read ends after one data transfer to a single location.

When the data bus is configured for 16 bits, demultiplexed address bits $A[2:1]$ are used to burst across up to four short-words. For an 8-bit data bus, demultiplexed address bits $A[1:0]$ are used to burst across up to four bytes.

Note: Burst write accesses to Flash Devices are not supported.

8.1.3 Bus Width

Each address range attributes are programmed in the PBI's boundary registers. The PBI allows an 8-, or 16-bit data bus width for each range. The PBI places 8- and 16-bit data on low-order data signals, simplifying the interface to narrow bus external devices. As shown in Figure 62, 8-bit data is placed on lines **AD[7:0]**; 16-bit data is placed on lines **AD[15:0]**.

Figure 62. Data Width and Low Order Address Lines

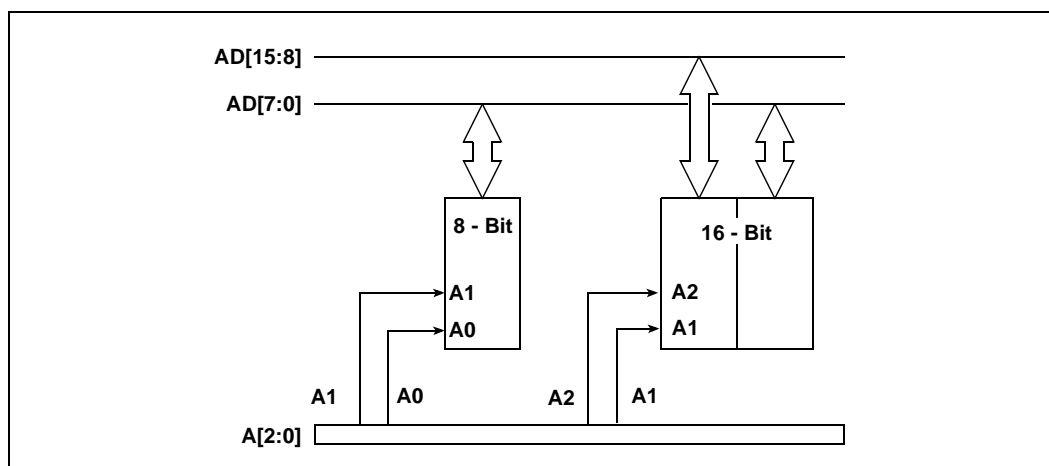

Flash memories need to be wired up in a manner consistent with the programmed bus width:

- 8-bit region: **A[1:0]** provide the demultiplexed byte address for a read burst.
- 16-bit region: **A[2:1]** provide the demultiplexed short-word address for a read burst.

Note: When using a 16 bit flash device mode **A0** is a “don’t care”.

During initialization, bus width is selected for each of the two address ranges in the Peripheral Base Address Registers (PBBAR0 - PBBAR1). In addition, the PBBAR0-PBBAR5 can be used to configure these ranges as Peripheral Windows and to set a Wait state profile.

The PBI drives determinate values on all address/data signals during T_W/T_D write operation states. For an 8-bit bus, the PBI continues to drive address on unused data signals **AD[15:8]**.

8.1.4 Flash Memory Support

PBI peripheral bus interface supports 8-, or 16- bit Flash devices.

The PBI provides programmable wait state functionality for peripheral memory windows.

Note: Potentially, programmable wait state functionality could be connected to any peripheral device that has a deterministic wait state profile. However, data valid and turn-around times need to fit within parameters provided by programmable wait state profiles to support Flash devices.

Any write transactions issued to a Flash address space window must always represent a single flash bus data cycle (**strb**, **strh**).

The peripheral chip enables, **PCE[1:0]#**, activate the appropriate Peripheral window when the address falls within one of the Peripheral address ranges.

Note: By default, bank 0 is enabled with the maximum number of Address-to-Data and Recovery Wait states. The width of the interface can be strapped for either 8-bit wide Flash or 16-bit wide flash. Thus, **PCE0#** is the Peripheral Bus chip enable to be used for booting purposes.

Figure 63 shows how two 8-bit Flash devices interface with 80331 through the PBI Interface.

Figure 63. Four MByte Flash Memory System¹

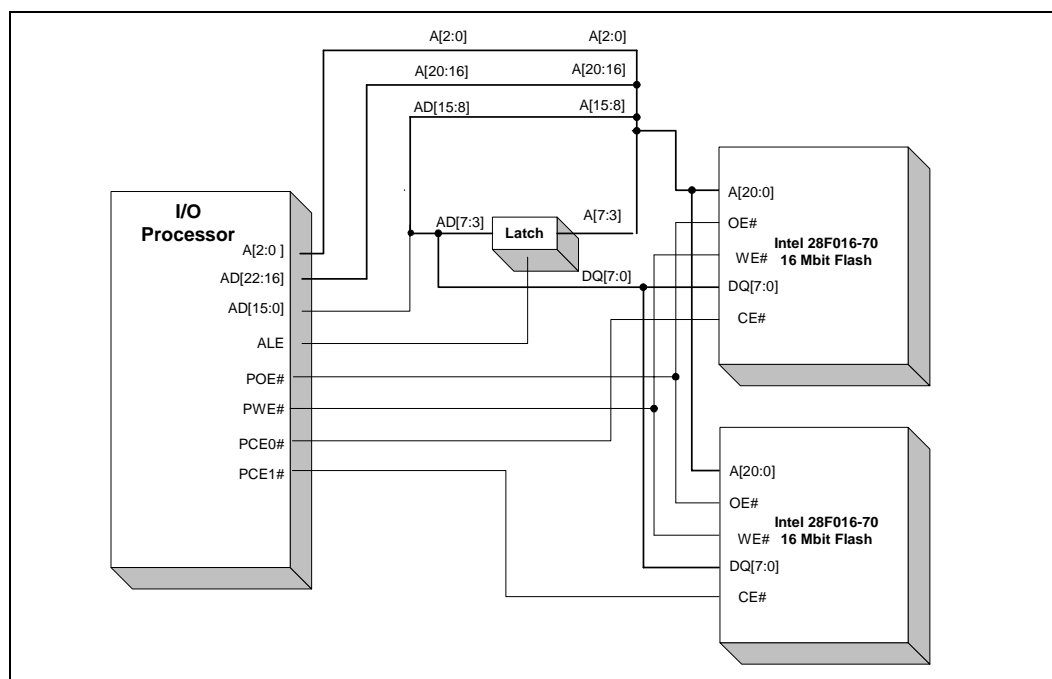

1. 16-bit wide flash devices requires two latches.

Refer to Table 72 for the programmable address-to data and recovery wait states. These numbers are based on a 66 MHz internal clock for the PBI interface.

Table 72. Flash Wait State Profile Programming¹

| Flash Speed | Address-to-Data Wait States | Recovery Wait States |
|-------------|-----------------------------|----------------------|
| <= 55 ns | 4 | 0 |
| <= 115 ns | 8 | 2 |
| <= 150 ns | 10 | 2 |

1. Each Wait State Represents 15 ns.

8.1.5 Layout Guidelines for the Peripheral Bus

This section provides basic layout guidelines for using the Peripheral Bus. Figures below provide the topology for simulation of clock, control and data lines.

Simulation Scope:

- Analysis consisted of an 8- or 16-bit address/data bus interfacing with one or two asynchronous flash devices operating at 66MHz.
- 50 ohm mother board and 60 ohm add-in card stackups were considered
- Lossy uncoupled transmission lines were used for the simulations
- Trace spacing were set 3X height of trace over reference plane to avoid crosstalk.
- The width of the bus (8/16 bits) and the number of flash devices yields six discrete topologies that were examined.
- Flash RC128J3A, CPLDs XC9500XL and Octal Latches 74LVC573A were used as loads in the SI analysis.

8.2 Topology Layout Guidelines

This section provides the topologies for routing the Address/Data bus for single load, latched single load and dual load latched topologies. Note that no length matching is required between the AD lines.

Figure 64. Peripheral Bus Unlatched Bidirectional Single Load Topology

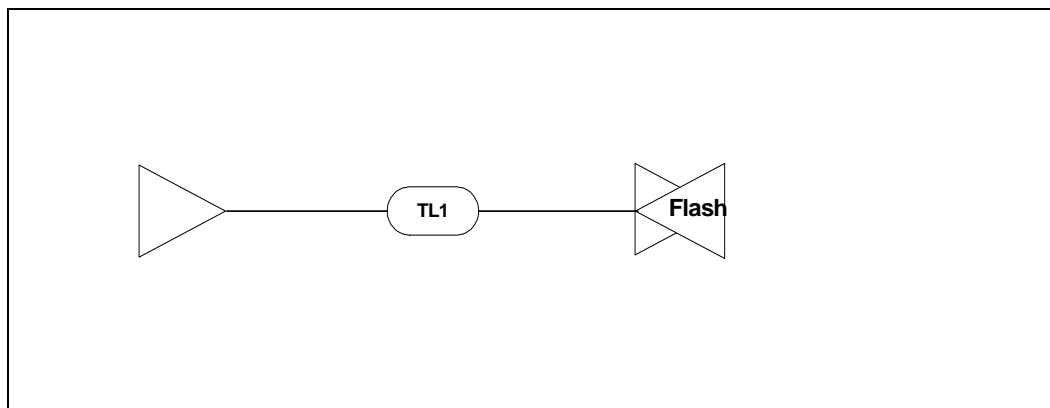

Table 73. Routing Guideline Bidirectional Single Load

| Parameter | Routing Guidelines |
|-----------------------------------------------------------|--------------------------------------------------------------------------------------------------------------------------------------------------------------|
| Reference Plane | Route over unbroken ground plane or power plane. If routing over power plane maintain this consistency throughout the topology. |
| Breakout | 5 mils on 5 mils spacing. Maximum length of breakout region is 500mils. |
| Routing | Microstrip or stripline or combination of microstrip and stripline. |
| Motherboard Impedance (for both microstrip and stripline) | 50 ohms +/- 15% |
| Add-in card Impedance (for both microstrip and stripline) | 60 ohms +/- 15% |
| Trace Spacing (center to center) | <ul style="list-style-type: none"> > 12 mils between all AD lines > 20 mils must be maintained from all other signals or vias. |
| Trace Length TL1 | 2.0" to 10.0" |
| Trace Length to strapping resistors | 0.5" to 3.0" from the last device on the bus. |
| Routing Recommendations | Number of vias for microstrip ≤ 2 |
| | Number of vias for stripline ≤ 4 |

Figure 65. Peripheral Bus Latched Bidirectional Single Load Topology

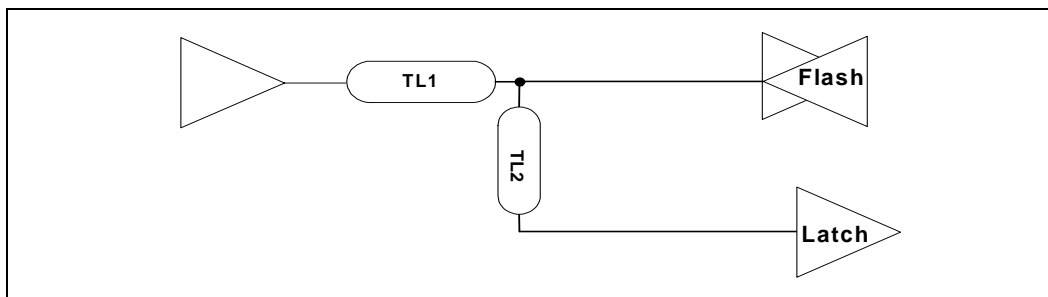

Table 74. Routing Guideline Latched Bidirectional Latch Single Load

| Parameter | Routing Guidelines |
|-----------------------------------------------------------|--------------------------------------------------------------------------------------------------------------------------------------------------------------|
| Reference Plane | Route over unbroken ground plane or power plane. If routing over power plane maintain this consistency throughout the topology. |
| Breakout | 5 mils on 5 mils spacing. Maximum length of breakout region is 500mils. |
| Routing | Microstrip or stripline or combination of microstrip and stripline. |
| Motherboard Impedance (for both microstrip and stripline) | 50 ohms +/- 15% |
| Add-in card Impedance (for both microstrip and stripline) | 60 ohms +/- 15% |
| Trace Spacing (center to center) | <ul style="list-style-type: none"> > 12 mils between all AD lines > 20 mils must be maintained from all other signals or vias. |
| Trace Length TL1 | 2.0" to 10.0" |
| Trace Length to TL2 | 0.5" to 2.0" |
| Trace Length to strapping resistors | 0.5" to 3.0" from the last device on the bus. |
| Routing Recommendations | Number of vias for microstrip \leq 2 |
| | Number of vias for stripline \leq 4 |
| | Route as daisy-chain only. |
| | Address latches for 16 bit implementations may be in any of the device locations for ease of routing. |

Figure 66. Peripheral Bus Latched Bidirectional Two Load Topology

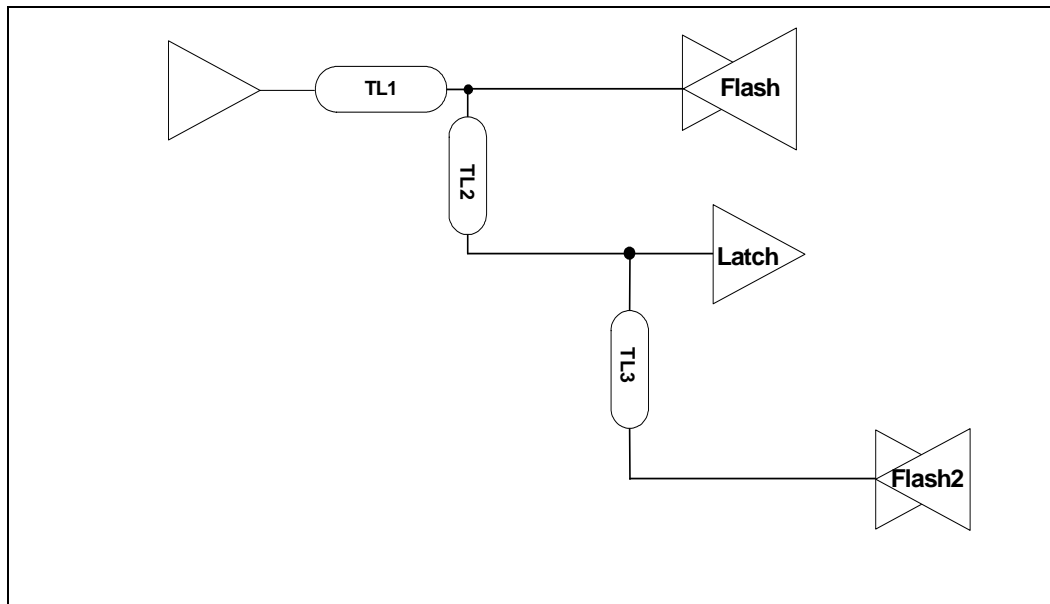

Table 75. Routing Guideline Latch Bidirectional Two Loads

| Parameter | Routing Guidelines |
|-----------------------------------------------------------|--------------------------------------------------------------------------------------------------------------------------------------------------------------|
| Reference Plane | Route over unbroken ground plane or power plane. If routing over power plane maintain this consistency throughout the topology. |
| Breakout | 5 mils on 5 mils spacing. Maximum length of breakout region is 500mils. |
| Routing | Microstrip or stripline minimize the layer changes. |
| Motherboard Impedance (for both microstrip and stripline) | 50 ohms +/- 15% |
| Add-in card Impedance (for both microstrip and stripline) | 60 ohms +/- 15% |
| Trace Spacing (center to center) | 16 mils (for microstrip 60 ohms or stripline 50/60 ohms) to 20 mils (for microstrip 50 ohms) |
| Trace Spacing (center to center) | <ul style="list-style-type: none"> > 12 mils between all AD lines > 20 mils must be maintained from all other signals or vias. |
| Trace Length TL1 | 2.0" to 10.0" |
| Trace Length TL2, TL3 | 0.5" to 2.0" |
| Trace Length to strapping resistors | 0.5" to 3.0" from the last device on the bus. |
| Routing Recommendations | Number of vias for microstrip ≤ 2 |
| | Number of vias for stripline ≤ 4 |
| | Route as daisy-chain only. |
| | Address latches for 16 bit implementations may be in any of the device locations for ease of routing. |

This Page Intentionally Left Blank

Power Delivery

9

There are several different voltage domains needed on the 80331. These include the following listed in Table 76:

Table 76. Intel® 80331 I/O Processor Bias Voltages

| Voltage Supply | Voltage |
|----------------------------|---------|
| PCI/Miscellaneous | 3.3V |
| DDR1 | 2.5V |
| DDR2 | 1.8V |
| IOP Core Voltage | 1.5V |
| Intel XScale® core Voltage | 1.35V |
| DDR1 Vref | 1.25V |
| DDR2 Vref | 0.9V |

9.1 Power Sequencing

The 80331 requires that the VCC33 voltage rail be powered up first and then the VCC15. Note that there are no sequence order requirements for the VCC25 or VCC18 rail. The power down sequence is the same in the reverse order.

- 1) VCC33 power up first
- 2) VCC15 power up second

The VCC33 greater than or equal to (or no less than 0.5V below) VCC15 (absolute voltage value) at all times during operations, including during system power-up and power-down. In other words, the following must always be true:

$$VCC33 \geq (VCC15 - 0.5V)$$

- This can be accomplished by placing a diode (with a voltage drop < 0.5V) between VCC15 and VCC33. an Anode is connected to VCC15 and a cathode is connected to VCC33.
- If a voltage regulator solution is used which shunts VCC15 to ground while VCC33 is powered, the maximum allowable time that VCC15 can be shunted to ground while VCC33 is fully powered is 20ms.
- The maximum allowed time between VCC33 and VCC15 ramping is 525ms. There is no minimum sequencing time requirement.

9.2 Power Failure

This section describes the power failure sequence and associated circuitry that is needed to prevent data loss during a power failure. While the host assumes all written data is stored on the non-volatile disk subsystem, the IOP must ensure that eventually all the data in the disk cache is actually stored onto disk. The power supply could fail to provide power to the I/O subsystem in the case of a power outage or a failed power supply. It is imperative that the cached data within the IOP's local memory is not lost. If power fails, the local memory subsystem must remain powered with a battery backup and some agent must continue to refresh at the appropriate interval specified by the memory component datasheet.

9.2.1 Theory of Operation

DDR SDRAM technology provides a simple way of enabling data preservation through the **self-refresh** command. This command is issued by the memory controller and the DDR SDRAM will refresh itself autonomously with internal logic and timers. The DDR SDRAM device will remain in self-refresh mode as long as:

1. The device continues to be powered.
2. **CKE** is held low until the memory controller is ready to control the DDR SDRAM once again.

Power to the DDR SDRAM subsystem is ensured with an adequate battery backup and a reliable method for switching between system power and battery power. The memory controller is responsible for deasserting **CKE[1:0]** when issuing the **self-refresh** command but while power gradually drops, **CKE[1:0]** **must** remain deasserted regardless of the state of V_{cc} powering the 80331.

9.2.2 Power Failure Sequence

Upon initial power-up, a power supply provides appropriate voltage to the system. The voltage level increases at a rate dependent on the type of power supply used and components in the system. In the specification, T_{fail} is defined as the time when **P_RST#** is asserted in response to the power rail going out of specification. T_{fail} is the minimum of:

- 500 ns from either power rail going out of specification (exceeding specified tolerances by more than 500 mV).
- 100 ns from the 5 V rail falling below the 3.3 V rail by more than 300 mV.

This proposal makes specific assumptions about the system behavior during a power failure. When the below assumptions are not guaranteed, it is the responsibility of the vendor to ensure them.

- **P_RST#** is asserted to 80331 when there is at least 2 μ s of reliable power remaining. This is required so that the memory controller can execute the power failure state machine in response to the assertion of **P_RST#**.

For storage applications, it is imperative that data cached within DDR memory system not be lost in a power failure condition. To prevent this from happening the local DDR memory needs to be saved with provisions for battery backup, to allow DDR data to be saved using the refresh mode at an appropriate interval until power is restored. The DDR has a self-refresh command that can be invoked as long as the device remains powered and **CKE** is held low. Power to DDR SDRAM is ensured with an automatic switch over to backup battery power when the system power is lost. Battery backup needs to maintain power on DDR voltages V_{DD} , V_{DDQ} and V_{REF} to prevent data loss. Refer to the *Intel® 80331 I/O Processor Developer's Manual*, for more information about this Power Failure Mode.

In order to trigger a power fail sequence while the IOP power is still valid operating range, a comparator circuit such as the one shown in Figure 67 is recommended.

Figure 67. Power Failure Comparator Circuit

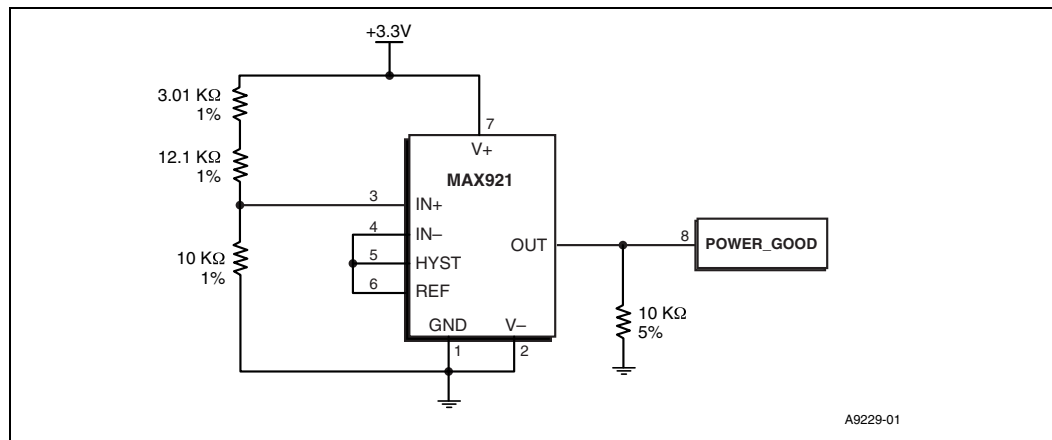

The comparator circuit shown in Figure 67 is used to trigger a power-fail sequence while the power to the IOP is still within valid operating conditions. The trip point of the comparator is set using the ratio of 0.4. This is set with the voltage divider values of the 10 K and the combined value 12.1 K and 3.01 K 1% resistors. This ratio provides a trip point value of 2.96 V. When the 3.3 V rail falls below the 2.96 V level, the PWGD signal is forced low. In the CRB, the **P_RST#** secondary side reset is tied to the **P_RST#** pin of the IOP. The **P_RST#** triggers the power-fail sequence.

9.2.3 Power Delay

The 80331 provides a dedicated input pin, **PWRDELAY** that will be used to distinguish between and initial power up and a power failure assertion of **PWRGD**. This signal should be pulled up with a 1.5K resistor.

9.3 Battery Backup

With a self-refresh command the DDR is able to store data. After a self-refresh command, the DDR refreshes itself autonomously with internal logic and timers. The DDR SDRAM remains in self-refresh mode as long as **CKE[1:0]** are low. CKE signals will stay low providing the DDR voltage is not removed from 80331. If 80331 is isolated from the DDR battery voltage it is recommended that the CKE circuit shown in [Figure 68](#) be implemented. The **CKE** latch circuitry in [Figure 68](#) is battery powered. It allows maintaining the **CKE[1:0]** signals low while the system power is off. The latches are cleared when the 80331 drives **CKE[1:0]** low with a self-refresh command and are reset when **PWRGD** is driven from low to high after system power is recovered. During normal operation, the **CKE** signals are controlled by the 80331. When the power is turned off, the battery powered latches pull the **CKE** signals low using the two transistors.

Note: It is recommended that the power planes for battery backup and the IOP power be isolated to avoid battery drain due to leakage when in battery backup mode. This can be implemented with a FET that isolates these planes during battery backup mode.

Figure 68. SCKE Circuit

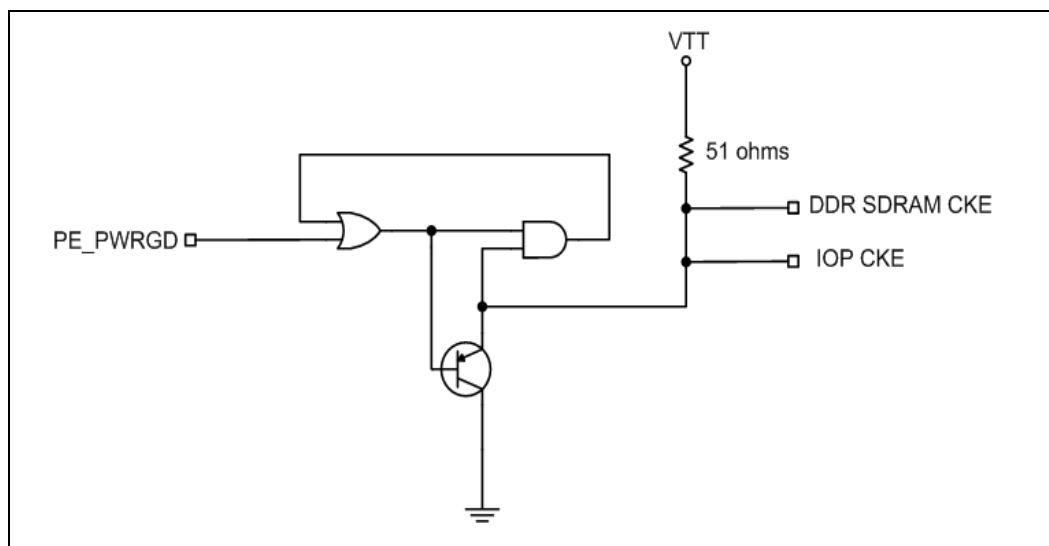

9.3.1 Non-Battery Backup Circuits

For applications not supporting battery back-up, this circuit not required. When so, follow these steps:

- Pull DDR **CKE** pins high and leave **CKE** signals on 80331 as 'no connects'. This keeps SDRAM from entering a pseudo, self-refresh mode, which can cause a lock-up condition on the SDRAM device.
- Pull the **PWRDELAY** pin low through a 1.5 K pull-down. Pulling it low has the effect of keeping the power fail state machine in reset, therefore not allowing the power fail sequence to ever occur.

This Page Intentionally Left Blank

Intel® IQ80331 Evaluation Platform Board

The Intel® IQ80331 Evaluation Platform Board (80331), also known as the evaluation board, is implemented as an add-in card.

This section provides an overview of the IQ80331 features and describes the circuits specific to the IQ80331.

Figure 69. Intel® IQ80331 Evaluation Platform Board CRB Block Diagram

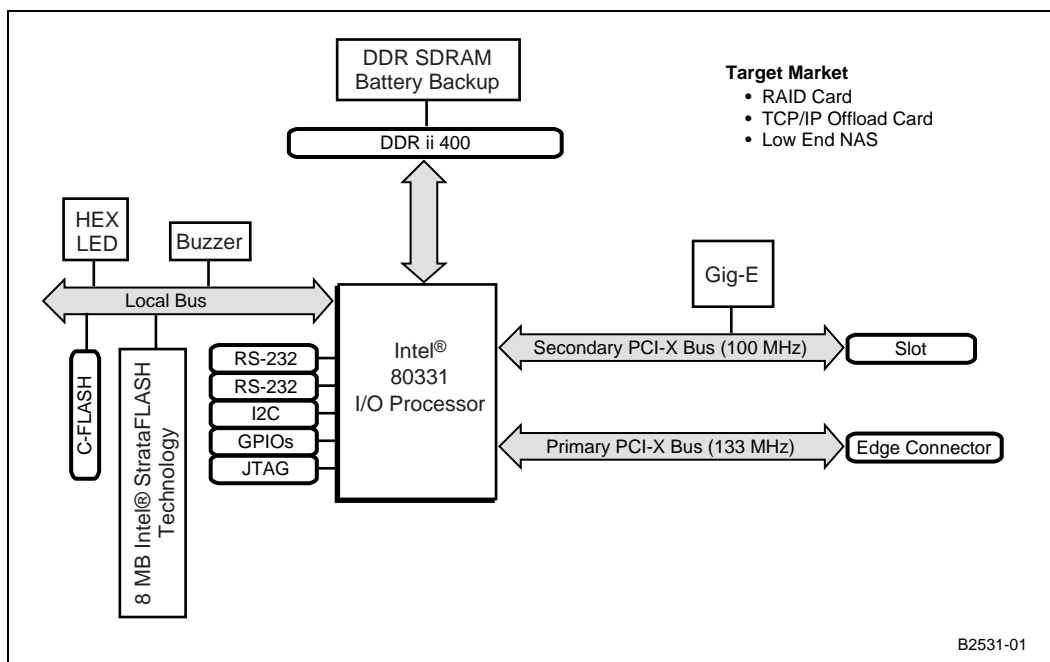
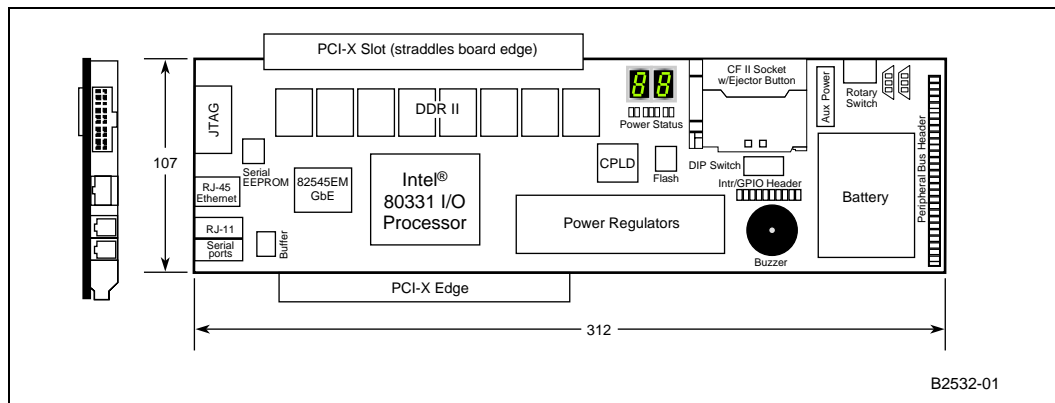

Table 77. Four Peaks Customer Reference Board Features

| Feature | Description |
|------------------------|------------------------------------------------------------------------------------------------------------------------------------------------------------------------------------------------------------------------------------------------------------------------------------------------------------------|
| Form Factor | Full-length PCI-X card (312mm x 107mm) |
| Processor | Integrated Intel® XScale™ core 500 MHz and 800MHz core frequencies supported |
| Memory | Double Data Rate II (DDRII) SDRAM 256 MB DDR II SDRAM soldered on the board Battery Back-up |
| | Flash Memory 8 MBytes Intel StrataFlash 16-bit interface |
| | Non-Volatile RAM (NVRAM) 2 KBytes serial I ² C EEPROM |
| Ethernet | Intel Gigabit Ethernet Controller 82545EM MAC PHY |
| I/O Connector | PCI-X (IOP Bus) – 64-bit card 3.3V slot connector - 100 MHz PCI-X Bus – 64-bit 3.3V edge connector - 133 MHz One RJ45 Ethernet port with integrated LEDs and magnetics on the bracket Dual RJ11 serial port connectors on the bracket Compact Flash Connector JTAG connector for the CPU and CPLD |
| Header | Interrupt & GPIO header Peripheral bus debug/expansion header 20-pin JTAG header for CPU and CPLD access 3 pin header for each I ² C bus |
| Logic Analyzer Probing | Provide access through standard connectors (i.e., PCI-X) |
| Misc. Functions | Temperature sensor |
| | Compact Flash |
| | Audible Alarm (Buzzer) |
| | Power On LED (Green) Indicators for each power plane |
| | CPLD <ul style="list-style-type: none"> Peripheral bus address latch and data buffers Misc. logic collection Misc. registers (Revision ID rotary switch, etc.) Address decode |

Figure 70. Intel® 80331 I/O Processor CRB Form Factor



JTAG Circuitry for Debug

11

Certain restrictions exist in order to use JTAG based debuggers with the Intel XScale[®] microarchitecture. This is primarily due to the Tap Controller reset requirements of the Intel XScale[®] microarchitecture and the reset requirements of specific JTAG debuggers. The following outlines these requirements along with suggestions for circuitry to alleviate potential problems

11.1 Requirements

The Intel[®] 80331 I/O processor (80331), like many others, requires that nTRST (Tap Reset) is asserted during power up. This is to ensure a fully initialized boundary scan chain. Failure to comply with this requirement may result in spurious behavior of the application.

The ARM* Multi-ICE* JTAG debugger requires that nTRST is always weakly pulled high. This requirement stems from the fact that the debugger can only assert nTRST (drive low). Both reset signals coming from the Multi-ICE™ (nTRST and nSRST) are open collector and must be weakly pulled high in order to avoid unintentional resets (System or TAP).

11.2 JTAG Signals / Header

Figure 71 is the pin definition (20-pin standard ARM connector) for JTAG.

Figure 71. JTAG Header Pin Out

| | | | |
|--------|----|----|---------|
| VTref | 1 | 2 | Vsupply |
| nTRST | 3 | 4 | GND |
| TDI | 5 | 6 | GND |
| TMS | 7 | 8 | GND |
| TCK | 9 | 10 | GND |
| RTCK | 11 | 12 | GND |
| TD0 | 13 | 14 | GND |
| nSRST | 15 | 16 | GND |
| DBGRQ | 17 | 18 | GND |
| DGBACK | 19 | 20 | GND |

A8982-01

The ARM Multi-ICE debugger along with the Macraigor Raven* and WindRiver Systems* visionPROBE / visionICE utilize this connector. The main difference to be noted is the specific implementation of nTRST for each debugger. The Macraigor Raven implementation actively drives nTRST (high and low). The WindRiver Systems* visionPROBE / visionICE can configure nTRST active or open collector (only drive low). ARM Multi-ICE is configured as open collector only.

11.3 System Requirements

In order to successfully invoke a debug session, the JTAG debug unit must be able to control nTRST and nSRST independently. The nTRST signal allows the debugger to get the TAP controller in a known state. The nSRST signal allows the debugger to control system/processor reset in order to download the debug handler via the JTAG interface.

Figure 72 and Figure 73 are used as examples without reflecting actual signal timings.

Figure 72. JTAG Signals at Powerup

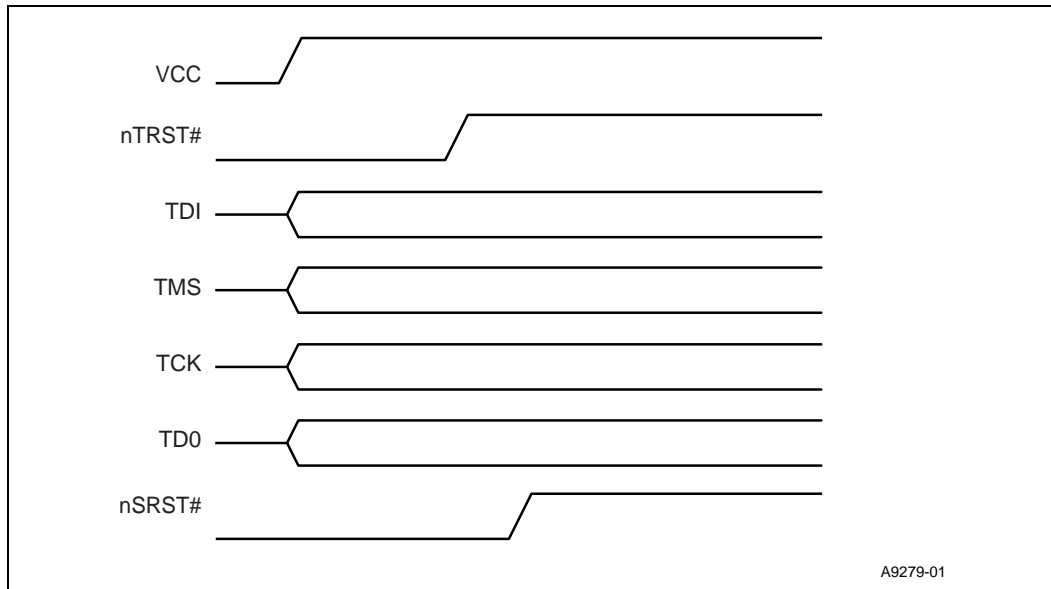
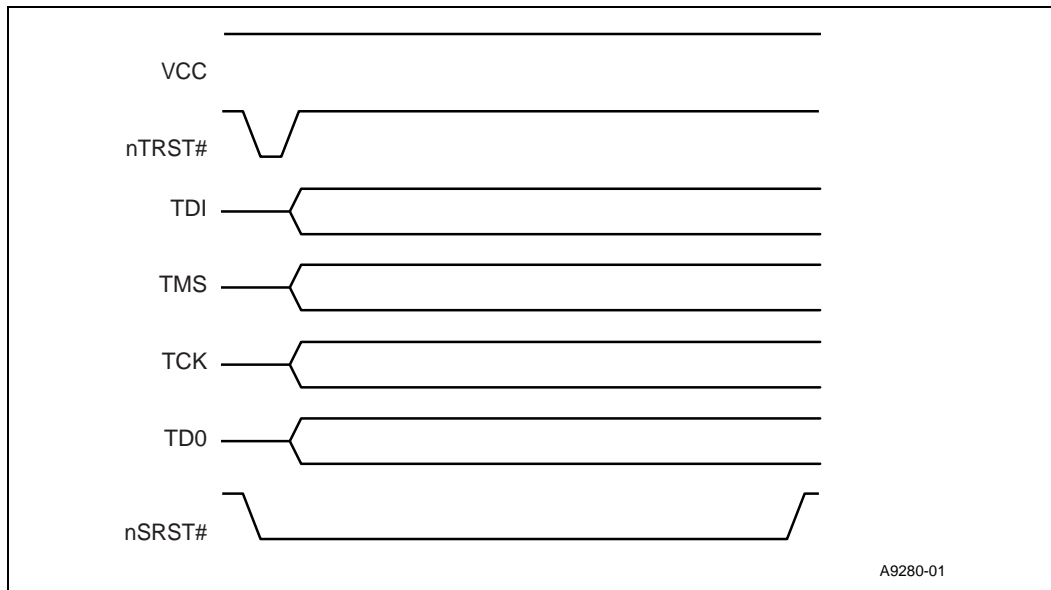

Figure 73. JTAG Signals at Debug Startup



11.4 JTAG Hardware Requirements

Due to the conflicting requirements of Multi-ICE* and the Intel XScale® microarchitecture, it is necessary to incorporate a circuit that can drive **TRST#** low at power up and weakly pull it high at all other times. The following section details the circuits required for the Macraigor Raven*, WindRiver Systems* visionPROBE* / visionICE*, and ARM* Multi-ICE*.

11.4.1 Macraigor Raven and WindRiver Systems visionPROBE / visionICE

Both the Macraigor Raven and WindRiver Systems visionPROBE / visionICE (when configured as active) do not require any special power-up circuitry. The requirement is that nTRST is weakly pulled down at the processor. It is suggested that the value of the pull-down resistor is 10 KΩ or greater. The value of this resistor needs to be confirmed with the JTAG debugger manufacturer to ensure optimal performance.

11.4.2 ARM Multi-ICE

The ARM Multi-ICE debugger requires special power-up circuitry due to the open collector implementation of the nTRST signal. This power-up circuit must ensure that nTRST is asserted (low) at power on and weakly pulled high thereafter. Refer to [Figure 74](#) for the example of the Power-Up Circuit for nTRST.

Figure 74. Example Power-Up Circuit for nTRST

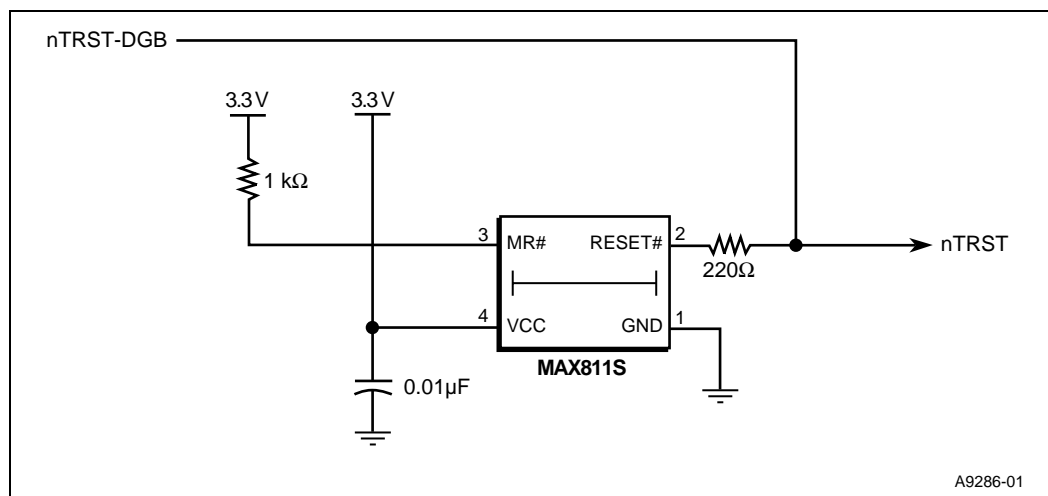

Debug Connectors and Logic Analyzer Connectivity 12

12.1 Probing PCI-X Signals

To ease the probing and debug of the PCI-X signals it is recommended to passively probe the PCI-X bus signals with a logic analyzer. This can be accomplished by placing six AMP* Mictor-38 connectors on the board or probing the bus with an interposer card such as the FuturePlus Systems* FS2007 that works with an Agilent Technologies* Logic Analyzer.

For ease of debugging the pin out of the AMP Mictor-38 connectors, the recommended pin-out matches the FuturePlus Systems* configuration setup, which allow ease of viewing the PCI signals on an Agilent Technologies* Logic Analyzer. Refer to the following test equipment that is used for this analysis:

- Two AMP 2-767004-2 surface mount connectors mounted on the target board and routed to the PCI-X Local bus.
- Two Agilent E5346A or E5351A High-Density Adapter Cables from FuturePlus System or Agilent Technologies.
- Four logic analyzer PODS.
- FS1104 Software from FuturePlus.

The equivalent for other analyzers can be substituted. A FuturePlus Systems configuration file with the FS1104 product that matches the pinout in [Table 78](#).

Table 78. Logic Analyzer Pod 1

| Mictor-38 #1 Pin Number Odd Pod | Logic Analyzer Channel Number | PCI-X Name |
|---------------------------------|-------------------------------|------------|
| 6 | CLKC/16 | CLK |
| 8 | 15 | C/BE4 |
| 10 | 14 | C/BE5 |
| 12 | 13 | C/BE6 |
| 14 | 12 | C/BE7 |
| 16 | 11 | ACK64 |
| 18 | 10 | REQ64 |
| 20 | 9 | UNUSED |
| 22 | 8 | PME |
| 24 | 7 | C/BEO |
| 26 | 6 | M66EN |
| 28 | 5 | C/BE1 |
| 30 | 4 | SERR |
| 32 | 3 | PAR |
| 34 | 2 | PERR |
| 36 | 1 | LOCK |
| 38 | 0 | STOP |

Table 79. Logic Analyzer Pod 2

| Mictor-38 #1 Pin Number Odd Pod | Logic Analyzer Channel Number | PCI-X Signal Name |
|---------------------------------|-------------------------------|-------------------|
| 5 | CLK/16 | FRAME |
| 7 | 15 | DEVSEL |
| 9 | 14 | TRDY |
| 11 | 13 | C/BE2 |
| 13 | 12 | C/BE3 |
| 15 | 11 | IDSEL |
| 17 | 10 | REQ |
| 19 | 9 | GNT |
| 21 | 8 | INTD |
| 23 | 7 | INTC |
| 25 | 6 | INTB |
| 27 | 5 | INTA |
| 29 | 4 | UNUSED |
| 31 | 3 | UNUSED |
| 33 | 2 | UNUSED |
| 35 | 1 | UNUSED |
| 37 | 0 | UNUSED |

Table 80. Logic Analyzer Pod 3

| Mictor-38 #2 Pin Number Odd Pod | Logic Analyzer Channel Number | PCI-X Signal Name |
|---------------------------------|-------------------------------|-------------------|
| 6 | CLK/16 | IRDY |
| 8 | 15 | AD15 |
| 10 | 14 | AD14 |
| 12 | 13 | AD13 |
| 14 | 12 | AD12 |
| 16 | 11 | AD11 |
| 18 | 10 | AD10 |
| 20 | 9 | AD09 |
| 22 | 8 | AD08 |
| 24 | 7 | AD07 |
| 26 | 6 | AD06 |
| 28 | 5 | AD05 |
| 30 | 4 | AD04 |
| 32 | 3 | AD03 |
| 34 | 2 | AD02 |
| 36 | 1 | AD01 |
| 38 | 0 | AD00 |

Table 81. Logic Analyzer Pod 4

| Mictor-38 #2 Pin Number Odd Pod | Logic Analyzer Channel Number | PCI-X Signal Name |
|---------------------------------|-------------------------------|-------------------|
| 5 | CLK/16 | UNUSED |
| 7 | 15 | AD31 |
| 9 | 14 | AD30 |
| 11 | 13 | AD29 |
| 13 | 12 | AD28 |
| 15 | 11 | AD27 |
| 17 | 10 | AD26 |
| 19 | 9 | AD25 |
| 21 | 8 | AD24 |
| 23 | 7 | AD23 |
| 25 | 6 | AD22 |
| 27 | 5 | AD21 |
| 29 | 4 | AD20 |
| 31 | 3 | AD19 |
| 33 | 2 | AD18 |
| 35 | 1 | AD17 |
| 37 | 0 | AD16 |

Table 82. Logic Analyzer Pod 5

| Mictor-38 #3 Pin Number Odd Pod | Logic Analyzer Channel Number | PCI-X Signal Name |
|---------------------------------|-------------------------------|-------------------|
| 6 | CLK/16 | PAR64 |
| 8 | 15 | AD47 |
| 10 | 14 | AD46 |
| 12 | 13 | AD45 |
| 14 | 12 | AD44 |
| 16 | 11 | AD43 |
| 18 | 10 | AD42 |
| 20 | 9 | AD41 |
| 22 | 8 | AD40 |
| 24 | 7 | AD39 |
| 26 | 6 | AD38 |
| 28 | 5 | AD37 |
| 30 | 4 | AD36 |
| 32 | 3 | AD35 |
| 34 | 2 | AD34 |
| 36 | 1 | AD33 |
| 38 | 0 | AD32 |

Table 83. Logic Analyzer Pod 6

| Mictor-38 Pin Number Even Pod | Logic Analyzer Channel Number | PCI-X Signal Name |
|-------------------------------|-------------------------------|-------------------|
| 5 | CLK/16 | Unused |
| 7 | 15 | AD63 |
| 9 | 14 | AD62 |
| 11 | 13 | AD60 |
| 13 | 12 | AD59 |
| 15 | 11 | AD58 |
| 17 | 10 | AD57 |
| 19 | 9 | AD56 |
| 21 | 8 | AD55 |
| 23 | 7 | AD54 |
| 25 | 6 | AD53 |
| 27 | 5 | AD52 |
| 29 | 4 | AD51 |
| 31 | 3 | AD50 |
| 33 | 2 | AD49 |
| 35 | 1 | AD48 |
| 37 | 0 | AD48 |

The recommended placement of the mictor connectors is at either end of the bus segment. The mictors are placed at the end of, as short a stub as possible, daisy chained off either end of the bus. When there is not enough room to place the mictors **0.5 inches** from the target, then an alternate method may be used. That is, to place the logic analyzer termination circuitry on the target and then extend the etch from the end of the termination circuitry over to the mictor connectors. The connection from the mictors to the logic analyzer must then be done with the **E5351A**. The **E5346A** contains the logic analyzer termination circuitry, the **E5351A** does not.

References

13

13.1 Related Documents

The following books and specifications may be helpful for designing with the Intel® 80331 I/O processor.

Table 84. Design References

| Design References |
|------------------------------------------------------------------------------------------------------------------------------------------------------------------------------|
| <i>Transmission Line Design Handbook</i> , Brian C. Wadell |
| <i>Microstrip Lines and Slotlines</i> , K. C. Gupta. Et al. |
| <i>PCI-X Addendum to the PCI Local Bus Specification</i> , Revision 1.0a |
| <i>PCI-X Electrical Subgroup Report, Version 1.0</i> |
| <i>Design, Modeling and Simulation Methodology for High Frequency PCI-X Subsystems</i> , Moises Cases, Nam Pham, Dan Neal www.pcisig.com |
| <i>PCI Local Bus Specification</i> , Revision 2.3 PCI Special Interest Group 1-800-433-5177 |
| <i>High-Speed Digital Design "A Handbook of Black Magic"</i> Howard W. Johnson, Martin Graham |
| <i>PCI Bus Power Management Interface Specification</i> , Revision 1.1 - PCI Special Interest Group |
| " <i>Terminating Differential Signals on PCBs</i> ", Steve Kaufer, Kelee Crisafulli, Printed Circuit Design, March 1999 |

Intel documentation is available from your local Intel Sales Representative or Intel Literature Sales.

To obtain Intel literature write to or call:

Intel Corporation
Literature Sales
P.O. Box 5937
Denver, CO 80217-9808
(1-800-548-4725) or visit the Intel website at <http://www.intel.com>

Table 85. Intel Related Documentation

| Document Title | Order # |
|---------------------------|---------|
| Intel® Packaging Databook | 240800 |



13.2 Electronic Information

Table 86. Electronic Information

| | |
|------------------------------------------|---------------------------------------------------------|
| The Intel World-Wide Web (WWW) Location: | http://www.intel.com |
| Customer Support (US and Canada): | 800-628-8686 |

