



Intel[®] Pentium[®] 4 Processor on 90 nm Process for Embedded Applications

Thermal Design Guide

November 2004

INFORMATION IN THIS DOCUMENT IS PROVIDED IN CONNECTION WITH INTEL® PRODUCTS. NO LICENSE, EXPRESS OR IMPLIED, BY ESTOPPEL OR OTHERWISE, TO ANY INTELLECTUAL PROPERTY RIGHTS IS GRANTED BY THIS DOCUMENT. EXCEPT AS PROVIDED IN INTEL'S TERMS AND CONDITIONS OF SALE FOR SUCH PRODUCTS, INTEL ASSUMES NO LIABILITY WHATSOEVER, AND INTEL DISCLAIMS ANY EXPRESS OR IMPLIED WARRANTY, RELATING TO SALE AND/OR USE OF INTEL PRODUCTS INCLUDING LIABILITY OR WARRANTIES RELATING TO FITNESS FOR A PARTICULAR PURPOSE, MERCHANTABILITY, OR INFRINGEMENT OF ANY PATENT, COPYRIGHT OR OTHER INTELLECTUAL PROPERTY RIGHT. Intel products are not intended for use in medical, life saving, life sustaining applications.

Intel may make changes to specifications and product descriptions at any time, without notice.

Designers must not rely on the absence or characteristics of any features or instructions marked "reserved" or "undefined." Intel reserves these for future definition and shall have no responsibility whatsoever for conflicts or incompatibilities arising from future changes to them.

The Intel® Pentium® 4 Processor on 90 nm Process for Embedded Applications may contain design defects or errors known as errata which may cause the product to deviate from published specifications. Current characterized errata are available on request.

Contact your local Intel sales office or your distributor to obtain the latest specifications and before placing your product order.

Copies of documents which have an order number and are referenced in this document, or other Intel literature, may be obtained by calling 1-800-548-4725, or by visiting Intel's website at <http://www.intel.com>.

AlertVIEW, AnyPoint, AppChoice, BoardWatch, BunnyPeople, CablePort, Celeron, Chips, CT Connect, CT Media, Dialogic, DM3, EtherExpress, ETOX, FlashFile, i386, i486, i960, iCOMP, InstantIP, Intel, Intel logo, Intel386, Intel486, Intel740, IntelDX2, IntelDX4, IntelSX2, Intel Create & Share, Intel GigaBlade, Intel InBusiness, Intel Inside, Intel Inside logo, Intel NetBurst, Intel NetMerge, Intel NetStructure, Intel Play, Intel Play logo, Intel SingleDriver, Intel SpeedStep, Intel StrataFlash, Intel TeamStation, Intel Xeon, Intel XScale, IPLink, Itanium, LANDesk, LanRover, MCS, MMX, MMX logo, Optimizer logo, OverDrive, Paragon, PC Dads, PC Parents, PDCharm, Pentium, Pentium II Xeon, Pentium III Xeon, Performance at Your Command, RemoteExpress, Shiva, SmartDie, Solutions960, Sound Mark, StorageExpress, The Computer Inside., The Journey Inside, TokenExpress, Trillium, VoiceBrick, Vtune, and Xircom are trademarks or registered trademarks of Intel Corporation or its subsidiaries in the United States and other countries.

*Other names and brands may be claimed as the property of others.

Copyright © Intel Corporation 2004. All rights reserved.

Contents

1.0	Introduction	5
1.1	Importance of Thermal Management.....	5
1.2	Document Goals.....	5
1.3	Document Scope.....	6
1.4	Related Documents.....	6
1.5	Definitions of Terms.....	6
2.0	Design Guidelines	9
2.1	Mechanical Guidelines.....	9
2.1.1	Processor Package.....	9
2.1.2	Motherboard Volumetric Constraint Requirements.....	12
2.1.3	Heatsink Attach.....	18
2.1.3.1	Retention Mechanism-ATX Form Factor.....	18
2.1.3.2	Heatsink Attach Clip.....	19
2.1.3.3	Additional Requirements for Solutions Using Reference ATX Heatsink and Reference Clip.....	19
2.1.4	Retention Mechanism-1U and 2U Form Factor.....	20
3.0	Characterizing Cooling Performance Requirements	23
3.1	Example of Cooling Performance.....	24
3.2	Looking at the Whole Thermal Solution.....	25
4.0	Thermal Design Guidelines	27
4.1	Processor Case Temperature.....	27
4.2	Processor Power and Thermal Specification.....	28
4.3	Thermal Solution Requirements.....	28
4.4	Recommended Thermal Solutions.....	30
4.4.1	Desktop/ATX Form Factor.....	30
4.4.2	1U Reference Thermal Solution.....	30
4.4.3	2U Reference Thermal Solution.....	31
4.5	Interface to Package Requirements.....	34
4.6	Thermal Interface Material Requirements.....	34
4.7	Package and Socket Load Specifications.....	35
5.0	Thermal Metrology for the Intel® Pentium® 4 Processor on 90 nm Process for Embedded Applications Processor	37
6.0	Thermal Test Vehicle Information	39
7.0	Thermal Monitor	41
8.0	Vendor Data	43

Figures

1	FC-mPGA4 Package Mechanical Drawing (Sheet 1 of 2).....	10
2	FC-mPGA4 Package Mechanical Drawing (Sheet 2 of 2).....	11
3	Motherboard Volumetric Constraint Footprint Definition and Height Restrictions—ATX Form Factor (Sheet 1 of 2).....	13
4	Motherboard Volumetric Constraint Footprint Definition and Height Restrictions—ATX Form Factor (Sheet 2 of 2).....	14
5	Volumetric Constraint for ATX/Desktop Form Factor Enabling Components.....	15
6	1U and 2U Reference Thermal Solution Primary Side PCB Volumetric Constraints	16
7	1U and 2U Reference Thermal Solution Secondary Side PCB Volumetric Constraints.....	17
8	Heatsink, Fan, and Shroud Assembly Volumetric Constraint, ATX Form Factor	20
9	Processor Thermal Characterization Parameter Relationships.....	24
10	Processor IHS Temperature Measurement Location	27
11	Thermal Resistance Values for Various Operating Temperatures	29
12	1U Thermal Solution Z-Height Constraints.....	31
13	2U Thermal Solution Z-Height Constraints.....	32
14	2U Reference Thermal Solution: Exploded View	33
15	Retention Mechanism 1.....	46
16	Retention Mechanism 2.....	47
17	1U Reference Thermal Solution Heatsink	48
18	2U Reference Thermal Solution Heatsink	49

Tables

1	Related Documents	6
2	Definitions of Terms.....	6
3	Processor Thermal Specifications	29
4	Recommended Thermal Solutions	30
5	Package Static and Dynamic Load Specifications	35
6	Vendor Contact Information.....	43

Revision History

Date	Revision	Description
November 2004	002	Updates for new processor SKU.
February 2004	001	Initial public release of this document.

1.0 Introduction

This document describes thermal design guidelines for the Intel® Pentium® 4 Processor on 90 nm Process for Embedded Applications in the Flip-Chip Pin Grid Array (FC-mPGA4) package that interfaces with the motherboard through a mPGA478B socket. The Intel® Pentium® 4 Processor on 90 nm Process is the latest processor in the Pentium 4 family. Detailed mechanical and thermal specifications for these processors may be found in the processor datasheet.

The information provided in this document is for reference only and additional validation must be performed prior to implementing the designs into final production. The intent of this document is to assist OEMs with the development of thermal solutions for their individual designs. The final heatsink solution, including the heatsink, attachment method, and Thermal Interface Material (TIM) must comply with the mechanical design, environmental, and reliability requirements delineated in the Intel® Pentium® 4 Processor on 90 nm Process *Datasheet*. It is the responsibility of each OEM to validate the thermal solution design with their specific applications.

1.1 Importance of Thermal Management

The objective of thermal management is to ensure that the temperatures of all components in a system are maintained within their functional temperature range. Within this temperature range, a component, and in particular its electrical circuits, is expected to meet its specified performance requirements. Operation outside the functional temperature range may degrade system performance, cause logic errors or cause component and/or system damage. Temperatures exceeding the maximum operating limit of a component may result in irreversible changes in the operating characteristics of this component.

In a system environment, the processor temperature is a function of both system and component thermal characteristics. The system-level thermal constraints consist of the local ambient air temperature and airflow over the processor as well as the physical constraints at and above the processor. The processor temperature depends in particular on the component power dissipation, the processor package thermal characteristics, and the processor thermal solution.

All of these parameters are aggravated by the continued push of technology to increase processor performance levels (higher operating speeds, GHz) and packaging density (more transistors). As operating frequencies increase and packaging size decreases, the power density increases while the thermal solution space and airflow typically become more constrained or remain the same within the system. The result is an increased importance on system design to ensure that the thermal design requirements are met for each component, including the processor, in the system.

1.2 Document Goals

The goal of this document is to describe the thermal characteristics of the Intel® Pentium® 4 Processor on 90 nm Process and provide guidelines for meeting the thermal requirements imposed on single-processor systems. The thermal solutions presented in this document are designed for embedded computing applications including ATX, 2U, and 1U server form factors.

1.3 Document Scope

This document discusses the thermal management techniques for the Intel® Pentium® 4 Processor on 90 nm Process, specifically in embedded computing applications. The physical dimensions and power numbers used in this document are for reference only. Refer to the processor's datasheet for the product dimensions, thermal power dissipation, and maximum case temperature. In case of conflict, the information in the datasheet supercedes any data in this document.

1.4 Related Documents

Table 1. Related Documents

Document Title	Reference Number
<i>Intel® Pentium 4 Processor on 90 nm Process Datasheet</i>	300561
<i>Intel® Pentium® 4 Processor on 90 nm Process Thermal and Mechanical Design Guidelines</i>	300564
<i>Intel® Pentium® 4 Processor 478-pin Socket (mPGA478) Design Guidelines</i>	249890

1.5 Definitions of Terms

Table 2. Definitions of Terms (Sheet 1 of 2)

Term	Definition
Bypass/no-bypass	Bypass is the area between a heatsink and any object that may act to form a duct. For this example it may be expressed as a dimension away from the outside dimension of the fins to the nearest surface.
CFM	Cubic Feet per Minute
HT	Hyper-threading; hyper-threading technology allows a single, physical processor to function as two logical processors.
LFM	Airflow velocity in Linear Feet per Minute
m478B Socket	The surface mount Zero Insertion Force (ZIF) socket designed to accept the Intel® Pentium® 4 Processor on 90 nm Process.
P_{Max}	The maximum processor power (theoretical maximum power).
$T_{Ambient-External}$	The measured ambient temperature at the OEM-defined external system location.
$T_{Ambient-Max}$	The target worst case local ambient temperature. To determine this, place the system in a maximum external temperature environment, and measure the ambient temperature surrounding the processor. Under these conditions, $T_{LA} = T_{Ambient-Max}$.
$T_{Ambient-OEM}$	The target worst-case ambient temperature at a given external system location as defined by the Original Equipment Manufacturer (OEM).
T_C	The measured case temperature of the processor.
T_{CMax}	The maximum case temperature of the processor, as specified in the processor datasheet.

Table 2. Definitions of Terms (Sheet 2 of 2)

Term	Definition
T_{LA} ($T_{Local-Ambient}$)	The measured ambient temperature locally surrounding the processor. The ambient temperature shall be measured just upstream of a passive heatsink, or at the fan inlet for an active heatsink.
Thermal Design Power (TDP)	A design point for the processor. OEMs must design thermal solutions that meet or exceed TDP and T-case specifications as specified by the processor's datasheet.
Thermal Interface Material (TIM)	The thermally conductive compound between the heatsink and processor case. This material fills the air gaps and voids, and enhances the spreading of the heat from the case to the heatsink.
U	A unit of measure used to define server rack spacing height. 1U is equal to 1.75 inches, 2U equals 3.50 inches, etc.
Ψ_{CA}	Case-to-Ambient thermal characterization parameter Ψ . A measure of thermal solution performance using total package power. Defined as $(T_C - T_A) / \text{Total package power}$. Note: Heat source must be specified for Ψ measurements
Ψ_{CS}	Case-to-Sink thermal characterization parameter. A measure of the thermal interface material performance using total package power. Defined as $(T_C - T_S) / \text{Total Package Power}$. Also referred to as Ψ_{TIM} . Note: Heat source must be specified for Ψ measurements.
Ψ_{SA}	Sink-to-Ambient thermal characterization parameter. A measure of heatsink thermal performance based on total package power. Defined as $(T_S - T_A) / \text{Total Package Power}$. Note: Heat source must be specified for Ψ measurements.

This page intentionally left blank.

2.0 Design Guidelines

The thermal solutions presented in this document are designed to fit within the maximum component height allowed by certain embedded form factor specifications, including ATX, 2U, and 1U server form factors. The thermal solutions may be valid for other form factors; however, individual applications must be modeled, prototyped, and verified.

In some cases, prototype parts have been fabricated for verification tests.

Note: The thermal verification information described in this document is not adequate for statistical purposes. The intent of testing was only to verify that the thermal components were performing within reasonable expectations, based on computer modeling and component specifications.

2.1 Mechanical Guidelines

2.1.1 Processor Package

The Intel® Pentium® 4 Processor on 90 nm Process is packaged in a Flip-Chip Pin Grid Array (FC-mPGA4) package technology. Refer to the processor datasheet for detailed mechanical specifications of the FC-mPGA4 package. For reference, the FC-mPGA4 package is shown in [Figure 1](#) and [Figure 2](#).

The package includes an Integrated Heat Spreader (IHS). The IHS spreads non-uniform heat from the die to the top of the IHS, out of which the heat flux is more uniform and on a larger surface area. This allows more efficient heat transfer out of the package to an attached cooling device.

It is incorrect to assume that processor power is dissipated uniformly on the IHS. In particular, when validating a thermal solution, an Intel® Pentium® 4 Processor on 90 nm Process Thermal Test Vehicle (TTV) should be used and a correlation to real parts applied to the results.

The IHS is designed to be the interface for mounting a heatsink. Further details are found in the processor datasheet.

The processor connects to the motherboard through a ZIF surface-mount socket. The socket is described in the *Intel® Pentium® 4 Processor, 478-Pin Socket (mPGA478B) Design Guidelines*.

To facilitate customer assembly and ensure proper alignment and cooling performance, the heatsink base must be designed for symmetrical assembly. Refer to [Section 2.1.3.3, “Additional Requirements for Solutions Using Reference ATX Heatsink and Reference Clip”](#) on page 19 for further information on the interface to the motherboard.

It is not recommended to use any portion of the interposer as a mechanical reference or load-bearing surface in either static or dynamic compressive load conditions.

Figure 1. FC-mPGA4 Package Mechanical Drawing (Sheet 1 of 2)

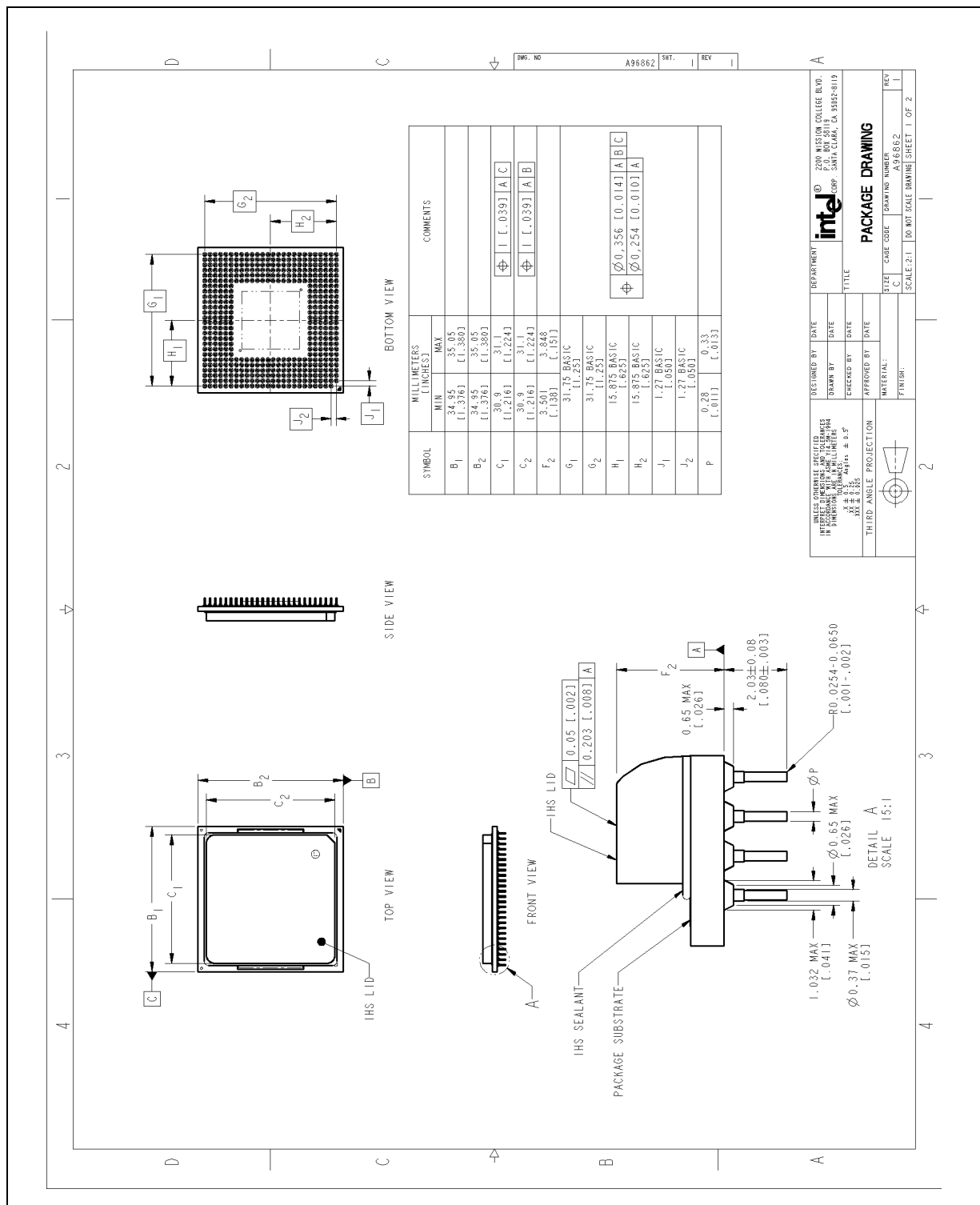
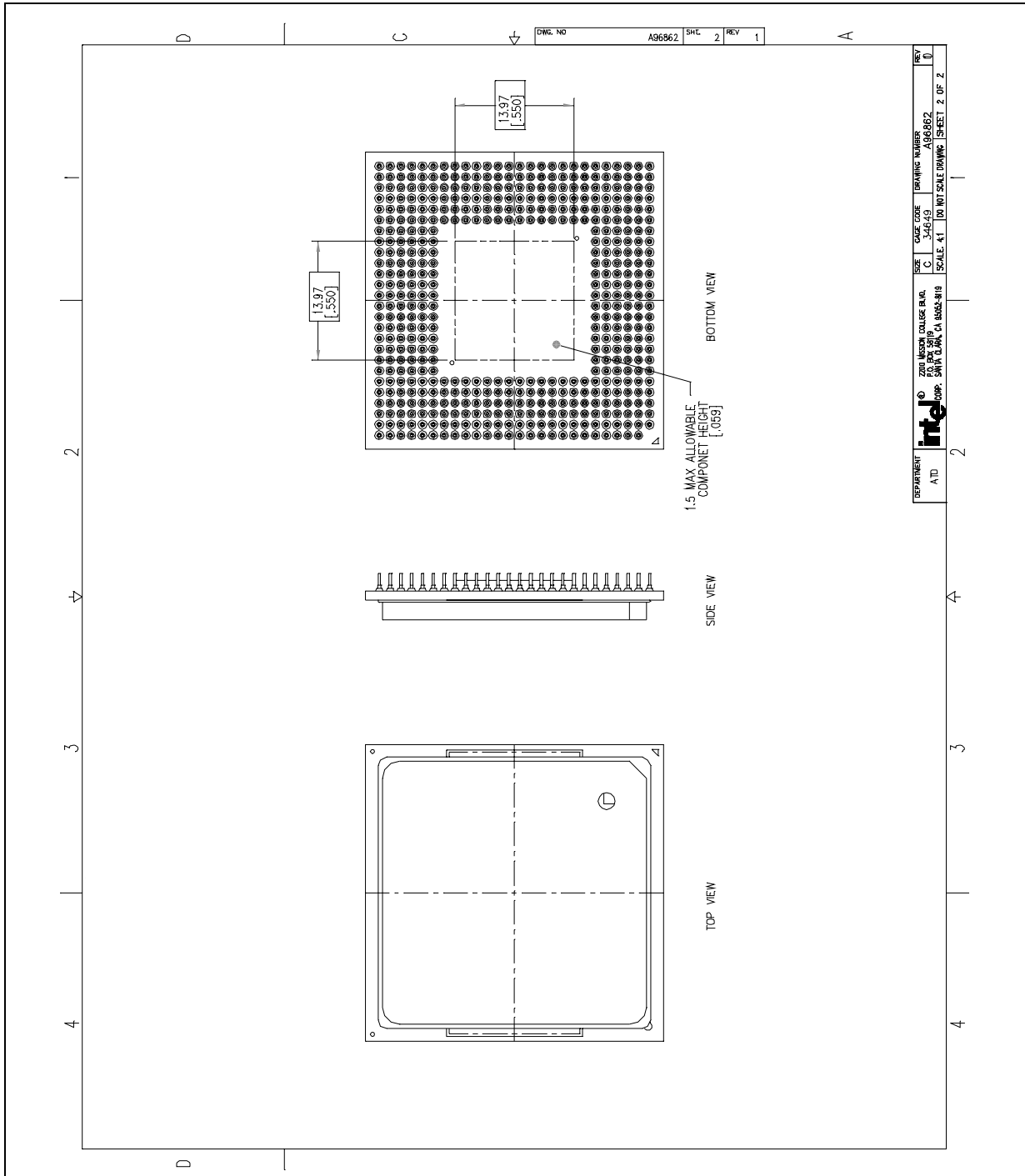

Figure 2. FC-mPGA4 Package Mechanical Drawing (Sheet 2 of 2)



2.1.2 Motherboard Volumetric Constraint Requirements

The volumetric constraint zone reserved for the processor package, heatsink, and heatsink attachment method for the baseboard is shown in [Figure 3](#), [Figure 4](#) and [Figure 5](#). These are the typical volumetric constraint zones for the FC-mPGA4 package and mPGA478B socket in the ATX form factor. [Figure 6](#) and [Figure 7](#) show the primary and secondary side volumetric constraint for the 1U and 2U reference thermal solutions.

Figure 3. Motherboard Volumetric Constraint Footprint Definition and Height Restrictions—ATX Form Factor (Sheet 1 of 2)

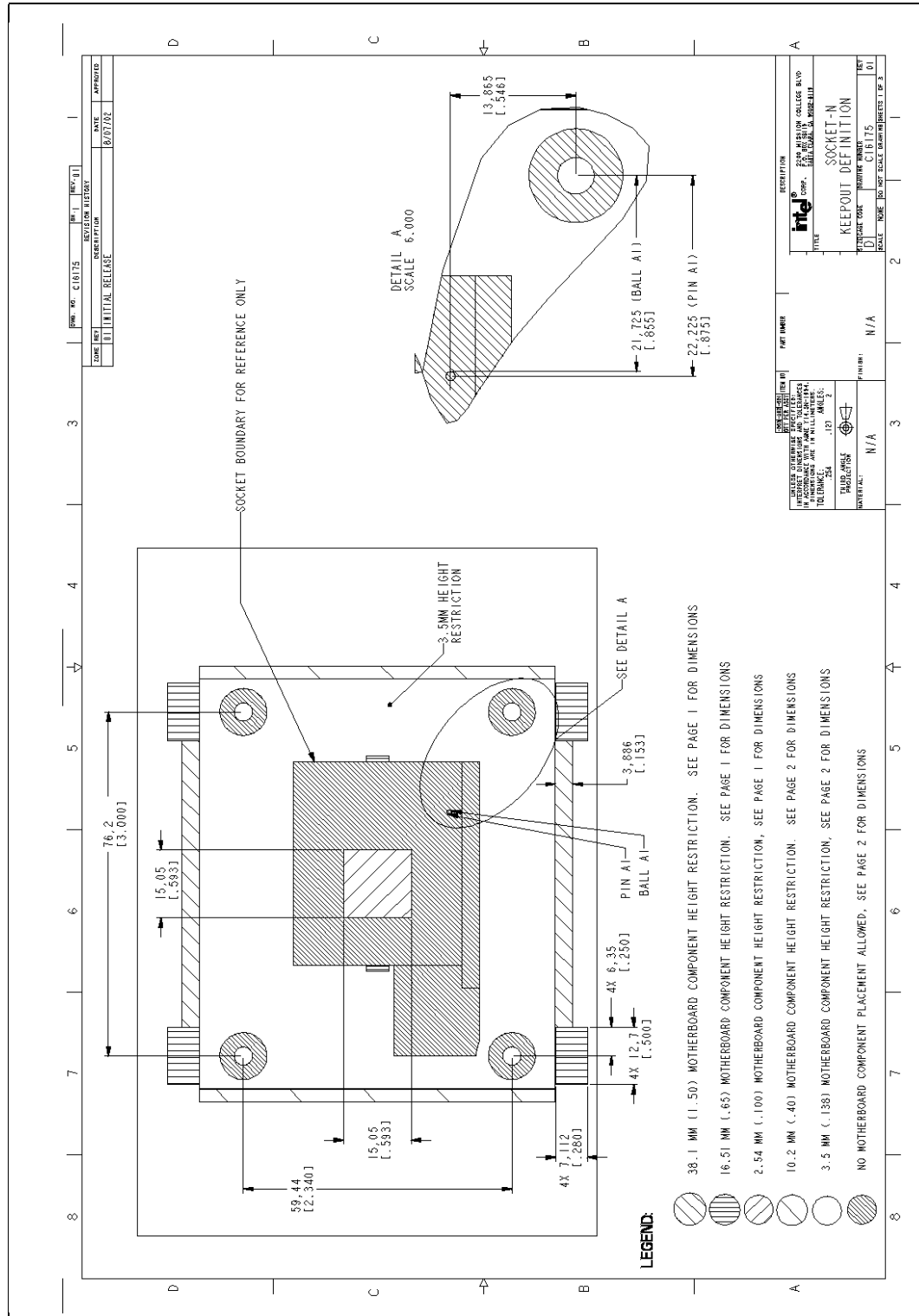

Figure 5. Volumetric Constraint for ATX/Desktop Form Factor Enabling Components

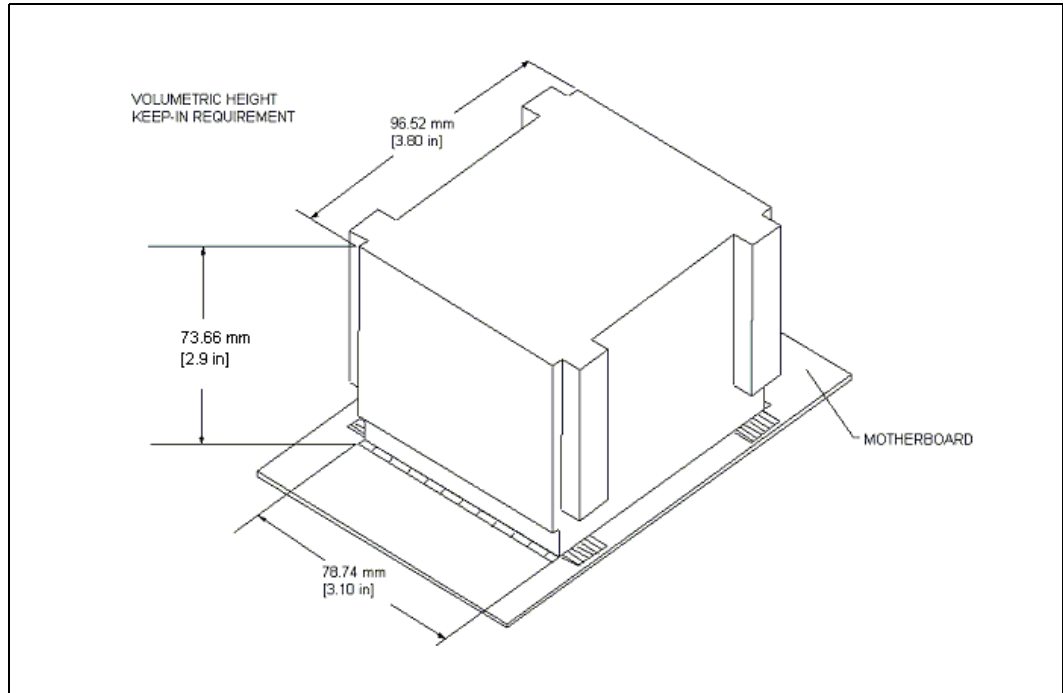

Figure 6. 1U and 2U Reference Thermal Solution Primary Side PCB Volumetric Constraints

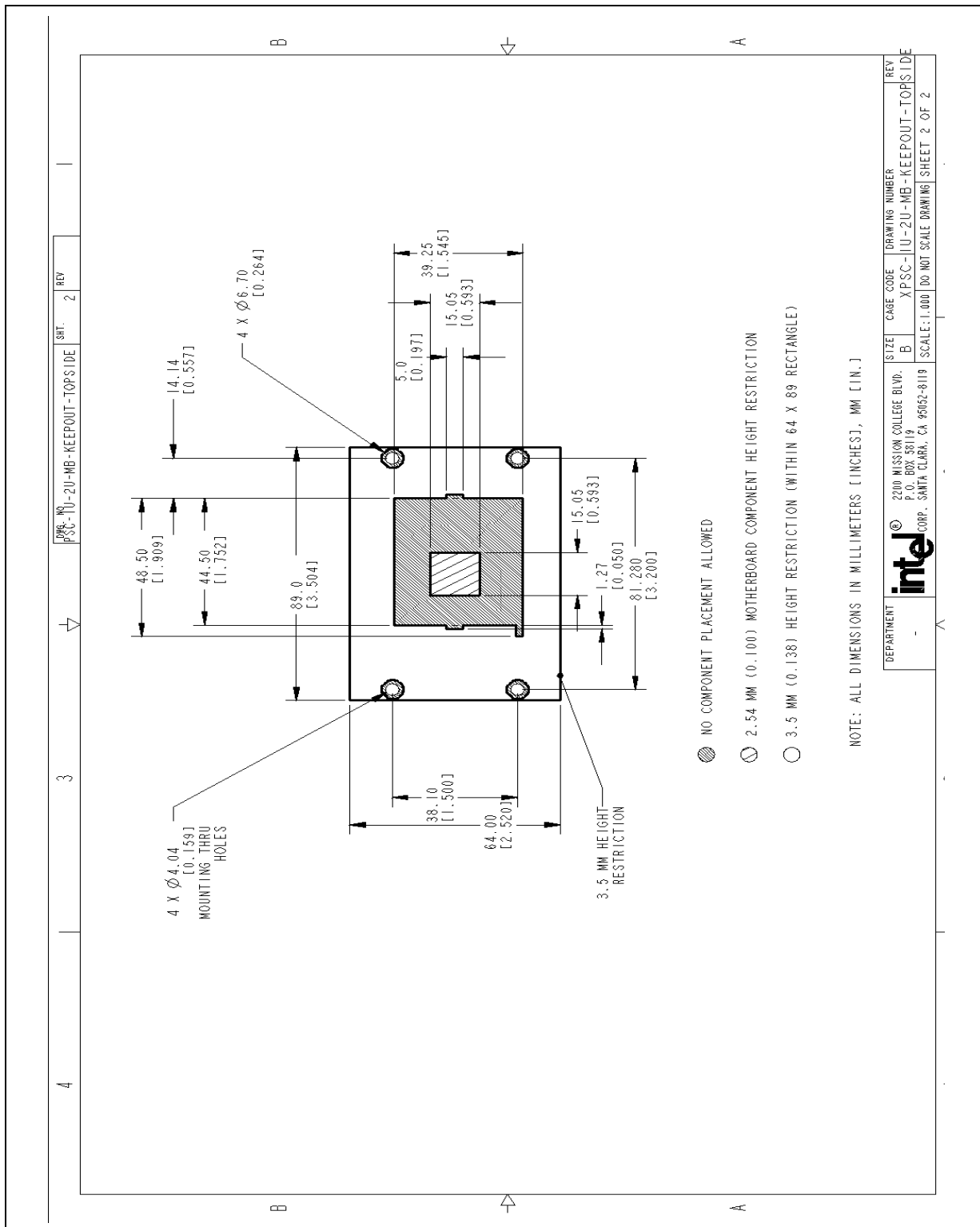
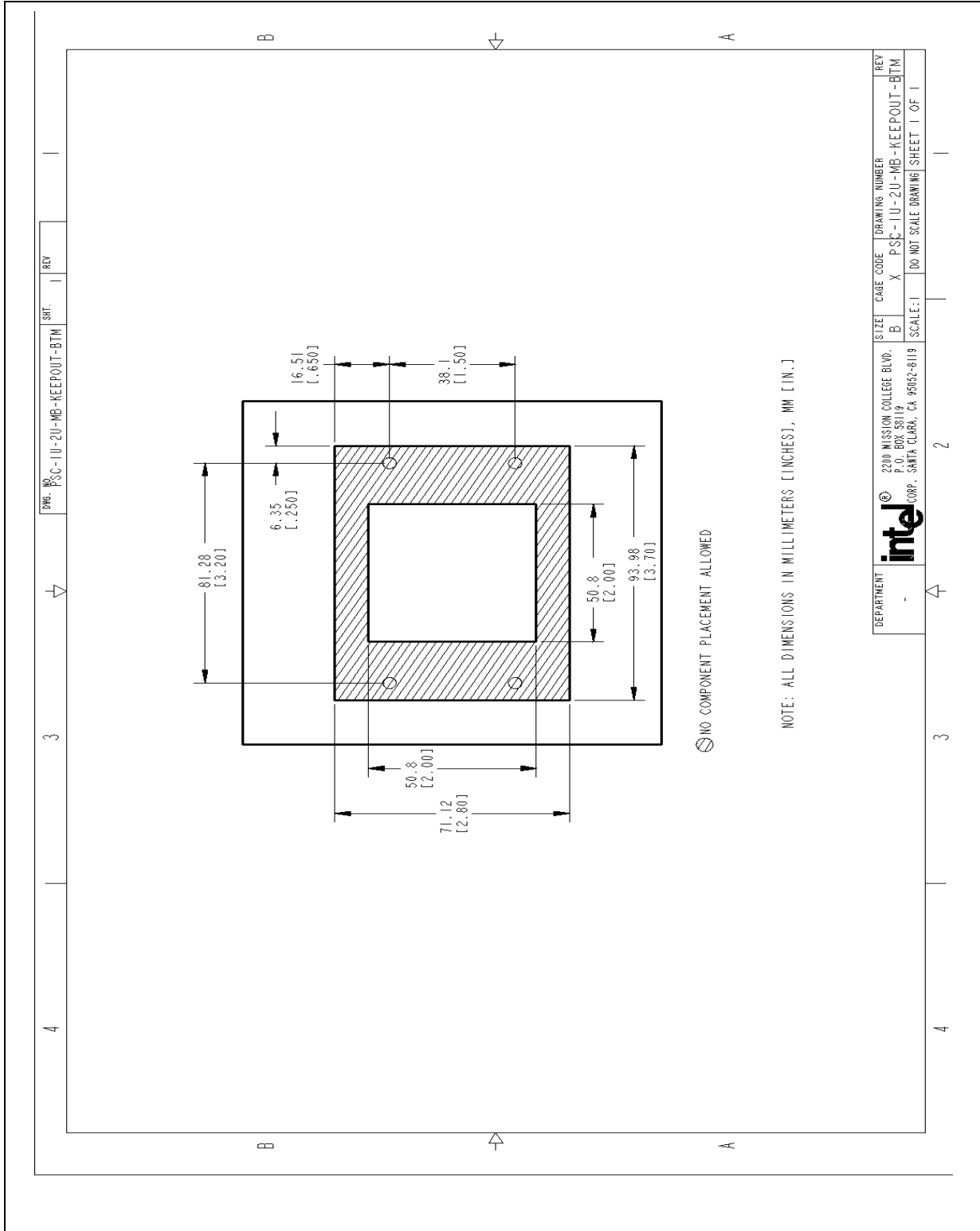

Figure 7. 1U and 2U Reference Thermal Solution Secondary Side PCB Volumetric Constraints



2.1.3 Heatsink Attach

There are no features on the mPGA478 socket to directly attach a heatsink; a heatsink attach mechanism must be designed to support the heatsink. The attach mechanism has two main roles:

- To ensure thermal performance to the TIM applied between the IHS and heatsink.
- To ensure system electrical, thermal, and structural integrity under shock and vibration events.

TIMs based on phase change materials are sensitive to applied pressure; the higher the pressure, the better the initial performance of the TIM. TIMs such as thermal greases are less sensitive to applied pressure.

The mechanical requirements of the attach mechanism depend on the weight of the heatsink and the level of shock and vibration that the system must support. The overall structural design of the motherboard and the system must be considered when designing the heatsink attachment mechanism. The design must provide a means for protecting the mPGA478 socket solder joints and prevent package pullout from the socket.

The most widely used form of attach mechanism is a Retention Mechanism (RM) and attach clips that secure the heatsink to the motherboard. The following sections contain more specific guidelines for designing an attach mechanism.

2.1.3.1 Retention Mechanism-ATX Form Factor

The thermal solution must be compatible with the Intel reference retention mechanism. Refer to [Figure 15](#) and [Figure 16](#) in [Appendix A, “Mechanical Drawings,”](#) for the mechanical drawing of the reference retention mechanism. The Intel reference retention mechanism is available for the Intel® Pentium® 4 Processor on 90 nm Process in the FC-mPGA4 package and is also recommended for the Intel® Pentium® 4 Processor on 90 nm Process heatsink.

Ask your Intel representative for model information in electronic format (IGES and DXF).

If another type of retention mechanism is developed, it must comply with the following guidelines:

- No tools required for assembly or installation to/removal from the motherboard.
- Symmetrical design allowing installation in either orientation.
- Installation force on the motherboard lower than 15 lbf.
- Motherboard interface compliant with motherboard volumetric constraints, as defined in [Figure 3](#) through [Figure 5](#). This includes:
 - Hole pattern information
 - Hole size
 - Board thickness: 0.062 inches (design specific).

2.1.3.2 Heatsink Attach Clip

2.1.3.2.1 Heatsink Attach Clip Usage

A heatsink attach clip holds the heatsink in place under dynamic loading and applies force to the heatsink base. It serves to:

- Maintain desired pressure on the TIM for thermal performance.
- Ensure that the package does not disengage from the socket during mechanical shock and vibration events (also known as package pullout).
- Protect solder joints from surface mount component damage during mechanical shock events if no other motherboard stiffening device is used.

The heatsink clip is latched to the retention tab features at each corner of the retention mechanism (see reference retention mechanism tab features in [Appendix A, “Mechanical Drawings”](#)).

2.1.3.2.2 Clip Structural Considerations

The heatsink attach clip must be able to support the mass of its corresponding heatsink during mechanical stress testing. The clip must remain engaged with the retention mechanism tab features and continue to provide adequate force to the heatsink base after mechanical stress testing for the thermal interface material to perform as expected. Maximum load is constrained by the package load capability, described in [Section 4.7, “Package and Socket Load Specifications” on page 35](#).

The clip must be designed in a way that makes it easy and ergonomic to engage with the retention mechanism tabs without the use of special tools. The force required to install the clip (during clip engagement to the retention mechanism tabs) shall not exceed 15 lbf. Clips that require more than 15 lbf to install may require a tool to make installation possible ergonomically.

2.1.3.2.3 Additional Clip Mechanical Design Guidelines

The heatsink clip must be designed in a way that minimizes contact with the motherboard surface during clip attachment to the retention mechanism tab features; the clip must not scratch the motherboard. All clip surfaces must be free of sharp edges to prevent injury to any system component or to the person performing the installation.

2.1.3.3 Additional Requirements for Solutions Using Reference ATX Heatsink and Reference Clip

This section defines the mechanical requirements for the interface between a processor heatsink/fan/shroud assembly and the reference retention mechanism. These requirements are intended to support interface control in the design of a custom thermal solution.

Requirement 1: Heatsink/fan/shroud assembly must stay within the volumetric keep-in defined in [Section 2.1.2, “Motherboard Volumetric Constraint Requirements” on page 12](#) and attach to the Intel reference retention mechanism defined in [Figure 15](#).

- *Guideline:* Rectangular heatsink base dimensions and tolerances:
 - X-dimension = 2.70 ± 0.010 inch
 - Y-dimension = 3.28 ± 0.010 inch
 - Z-dimension: Inset in bottom surface of heatsink base in each of four corners shall hold a z-dimension of 0.073 ± 0.010 inch

These dimensions are recommended to limit heatsink movement (rocking and sliding) during lateral shock (x and y directions).

Requirement 2: Maximum mass and center of gravity (CG)

- The maximum combined mass of the heatsink/fan/shroud assembly is 450 grams.
- The combined center of gravity of the heatsink/fan/shroud assembly must be no greater than 0.85 inches above the motherboard.

Figure 8 shows the heatsink, fan, and shroud assembly volumetric keep-in for the ATX form factor.

Figure 8. Heatsink, Fan, and Shroud Assembly Volumetric Constraint, ATX Form Factor

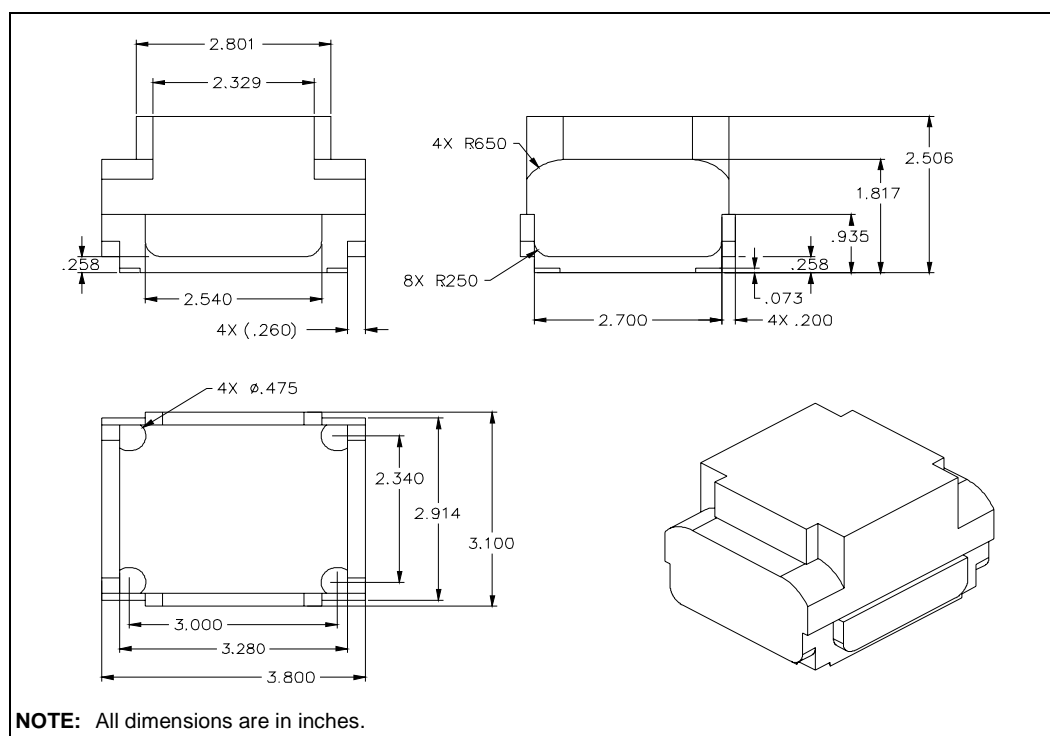

2.1.4 Retention Mechanism-1U and 2U Form Factor

The reference thermal solutions enabled by Intel for the 1U and 2U form factor are not attached to the processor with the use of the standard reference retention mechanism and clip due to form factor constraints. These reference design thermal solutions are attached to the processor using a spring loaded fastener and a backplate. The PCB primary and secondary side keep-out recommendations for these solutions are shown in Figure 6 and Figure 7 in Section 2.1.2, “Motherboard Volumetric Constraint Requirements” on page 12. Information on the fastener may be obtained from your Intel field sales representative.

If another method of attaching the thermal solution to the processor is desired, it must comply with package and socket loading specification as delineated in Section 4.7, “Package and Socket Load Specifications” on page 35.

In addition, the thermal solution must apply sufficient pressure on the IHS to:

- Maintain desired pressure on the TIM for thermal performance.
- Ensure that the package does not disengage from the socket during mechanical shock and vibration events (also known as package pullout).
- Protect solder joints from surface mount component damage during mechanical shock events if no other motherboard stiffening device is used.

This page intentionally left blank.

3.0 Characterizing Cooling Performance Requirements

The idea of a “thermal characterization parameter,” Ψ (psi) is a convenient way to characterize the performance needed for the thermal solution and to compare thermal solutions in identical situations (heating source, local ambient conditions). A thermal characterization parameter is convenient in that it is calculated using total package power, whereas actual thermal resistance, θ (theta), is calculated using actual power dissipated between two points. Measuring actual power dissipated into the heatsink is difficult, since some of the power is dissipated via heat transfer into the socket and board. Be aware, however, of the limitations of lumped parameters such as Ψ when it comes to a real design. Heat transfer is a three-dimensional phenomenon that can rarely be accurately and easily modeled by lump values.

The case-to-local ambient thermal characterization parameter value (Ψ_{CA}) is used as a measure of the thermal performance of the overall thermal solution that is attached to the processor package. It is defined by [Equation 1](#) and measured in units of °C/W:

Equation 1. Case-to-Local Ambient Thermal Characterization Parameter Value (1)

$$\Psi_{CA} = (T_C - T_A) / P_D$$

Where:

Ψ_{CA} = Case-to-local ambient thermal characterization parameter (°C/W)

T_C = Processor case temperature (°C)

T_A = Local ambient temperature (T_{LA}) in chassis at processor (°C)

P_D = Processor total power distribution (W). Assumes all power dissipates through the IHS

The case-to-local ambient thermal characterization parameter of the processor, Ψ_{CA} , is composed of Ψ_{CS} , the thermal interface material thermal characterization parameter, and of Ψ_{SA} , the sink-to-local ambient thermal characterization parameter in [Equation 2](#):

Equation 2. Case-to-Local Ambient Thermal Characterization Parameter Value (2)

$$\Psi_{CA} = \Psi_{CS} + \Psi_{SA}$$

Where:

Ψ_{CS} = Thermal characterization parameter of the thermal interface material (°C/W)

Ψ_{SA} = Thermal characterization parameter from heatsink-to-local ambient (°C/W)

Ψ_{CS} is strongly dependent on the thermal conductivity and thickness of the TIM between the heatsink and IHS

Ψ_{SA} is a measure of the thermal characterization parameter from the bottom of the heatsink to the local ambient air. Ψ_{SA} is dependent on the heatsink material, thermal conductivity, and geometry. It is also strongly dependent on the air velocity through the fins of the heatsink.

Figure 9 illustrates the combination of the different thermal characterization parameters.

Figure 9. Processor Thermal Characterization Parameter Relationships

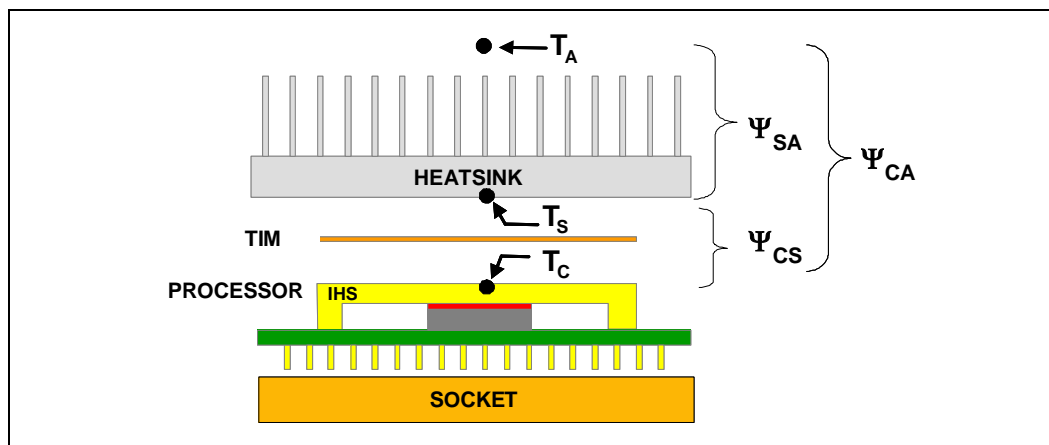

3.1 Example of Cooling Performance

The cooling performance, Ψ_{CA} , is defined using the principle of thermal characterization parameter described above:

- Define a target case temperature $T_{CM_{max}}$ and corresponding Thermal Design Power (TDP) at a target frequency, F, given in the *Intel® Pentium® 4 Processor on 90 nm Process Datasheet*.
- Define a target local ambient temperature at the processor, T_A .

Since the processor thermal specifications ($T_{CM_{max}}$ and TDP) may vary with the processor frequency, it is important to identify the worst case (lowest Ψ_{CA}) for a targeted chassis (characterized by T_A) to establish a design strategy such that a given heatsink can cover a given range of processor frequencies.

The following example illustrates how one might determine the appropriate performance targets. The example power and temperature numbers used here are not related to any Intel processor thermal specifications and are for illustrative purposes only.

Assume the processor TDP is 89 W and the case temperature specification is 69° C for a given frequency. Assume as well that the system airflow has been designed such that the local processor ambient temperature is 42° C. The following could be calculated using [Equation 1](#) from above for the given frequency:

$$\Psi_{CA} = (T_C - T_A) / TDP = (69 - 42) / 89 = 0.303^\circ C/W$$

To determine the required heatsink performance, a heatsink solution provider would need to determine Ψ_{CS} performance for the selected TIM and mechanical load configuration. If the heatsink solution were designed to work with a TIM material performing at $\Psi_{CS} \leq 0.1^\circ C/W$, solving for [Equation 2](#) from above, the performance of the heatsink would be:

$$\Psi_{SA} = \Psi_{CA} - \Psi_{CS} = 0.303 - 0.1 = 0.203^\circ C/W$$

If the local processor ambient temperature is assumed to be 40° C, the same calculation may be performed to determine the new case-to-ambient thermal resistance:

$$\Psi_{CA} = (T_C - T_A) / TDP = (69 - 40) / 89 = 0.326^\circ \text{ C/W}$$

It is evident from the above calculations that a reduction in the local processor ambient temperature has a significant positive effect on the case-to-ambient thermal resistance requirement.

3.2 Looking at the Whole Thermal Solution

The heat generated by components within the chassis must be removed to provide an adequate operating environment for both the processor and other system components. Moving air through the chassis brings in air from the external ambient environment and transports the heat generated by the processor and other system components out of the system. The number, size and relative position of fans and vents have a decisive impact on the chassis thermal performance, and therefore on the ambient temperature around the processor. The size and type (passive or active) of the thermal cooling device and the amount of system airflow are related and may be traded off against each other to meet specific system design constraints. Additional constraints are board layout, spacing, component placement, and structural considerations that limit the thermal solution size. For more information, refer to the *Performance ATX Desktop System Thermal Design Suggestions* or *Performance microATX Desktop System Thermal Design Suggestions* available at <http://www.formfactors.org/>. For more information on server standards, visit the Server System Infrastructure web site at <http://www.ssiforum.org/>.

In addition to passive heatsinks, fan heatsinks and system fans, other solutions exist for cooling integrated circuit devices. For example, ducted blowers, heat pipes and liquid cooling are all capable of dissipating additional heat. Due to their varying attributes, each of these solutions may be appropriate for a particular system implementation.

To develop a reliable, cost-effective thermal solution, thermal characterization and simulation shall be carried out at the entire system level, accounting for the thermal requirements of each component. In addition, acoustic noise constraints may limit the size, number, placement, and types of fans that may be used in a particular design.

To ease the burden on cooling solutions, the Intel Thermal Monitor feature and associated logic have been integrated into the silicon of the Intel® Pentium® 4 Processor on 90 nm Process. By taking advantage of the Intel Thermal Monitor, system designers may reduce cooling system cost while maintaining processor reliability and performance goals. For more information about the Intel Thermal Monitor, refer to the *Intel® Pentium® 4 Processor on 90 nm Process Datasheet*.



This page intentionally left blank.

4.0 Thermal Design Guidelines

This section presents thermal solution design guidelines for the Intel® Pentium® 4 Processor on 90 nm Process in the 478-pin package in three different form factors: desktop/ATX, 2U, and 1U server. The required performance of the thermal solution is dependent on many parameters, including the processor’s thermal design power (TDP), maximum case temperature ($T_{C\ MAX}$), operating ambient temperature, and system airflow. The guidelines and recommendations presented in this section are based on specific parameters. It is the responsibility of each product design team to verify that thermal solutions are suitable for their specific use.

The thermal metrology for the Intel® Pentium® 4 Processor on 90 nm Process must be followed to evaluate the thermal performance of proposed cooling solutions. To develop a reliable thermal solution, all of the appropriate variables must be considered. Thermal simulations and characterizations must be carried out with all system parameters accounted for. The solutions presented in this document must be validated as specified in their final intended system.

4.1 Processor Case Temperature

The case temperature is defined as the temperature measured at the center of the top surface of the IHS. For illustration, the measurement location for a 35 mm x 35 mm FC-mPGA4 package is shown in Figure 10. In case of conflict, the dimensions of the processor package in the datasheet supercede the information in this document.

Techniques for measuring the case temperature are detailed the *Intel® Pentium® 4 Processor on 90 nm Process Thermal and Mechanical Design Guidelines*.

Figure 10. Processor IHS Temperature Measurement Location

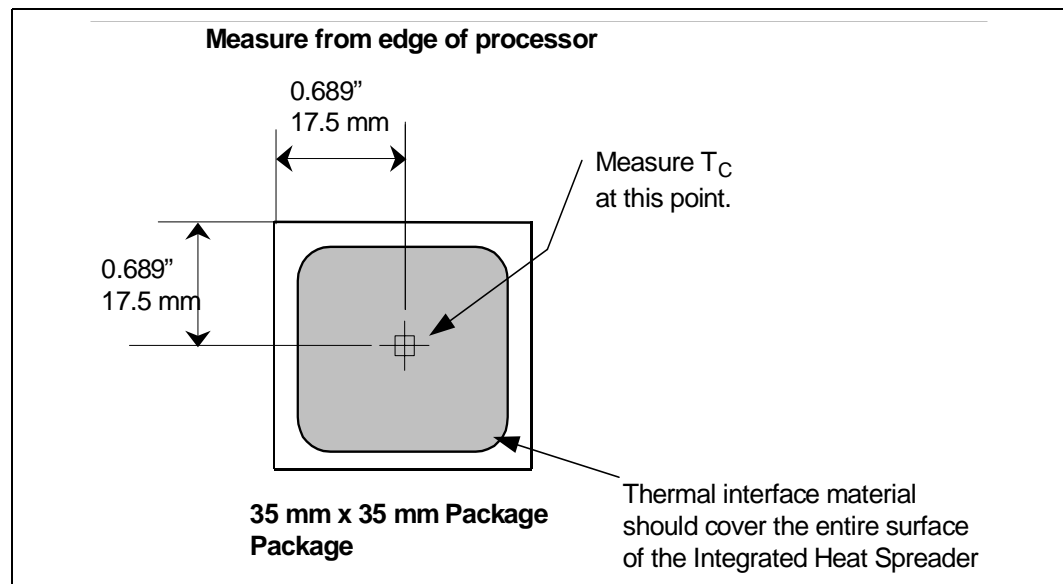

4.2 Processor Power and Thermal Specification

The Intel® Pentium® 4 Processor on 90 nm Process introduces a new methodology for determining processor case temperature based on the power dissipation of the processor. This new methodology is called the Thermal Profile and it defines the T_C requirements based on the power dissipation of the processor. The Thermal Design Power (TDP) and T_C requirements can be seen in the Thermal Profile located in the *Intel® Pentium® 4 Processor on 90 nm Process Datasheet*. The thermal profile for the Intel® Pentium® 4 Processor on 90 nm Process is based on the Intel desktop reference thermal solution which will operate up to a maximum local ambient temperature (T_{LA}) of 38°C. If a system integrator would like to design a thermal solution at a higher ambient temperature, they must meet the T_C specifications as outlined by the Intel® Pentium® 4 Processor on 90 nm Process thermal profile in the *Intel® Pentium® 4 Processor on 90 nm Process Datasheet* up to a T_{LA} of 43.3°C.

To allow for the optimal operation and long-term reliability of Intel processor-based systems, the system/processor thermal solution should be designed such that the processor remains within the minimum and maximum case temperature (T_C) specifications when operating at or below the Thermal Design Power (TDP) value listed in the *Intel® Pentium® 4 Processor on 90 nm Process Datasheet* thermal profile. Thermal solutions not designed to provide this level of thermal capability may affect the long-term reliability of the processor and system and may also increase the risk of activating the Thermal Control Circuit (TCC).

One intention of the thermal profile is to support acoustic noise reduction through fan speed control. Selection of the appropriate fan speed will be based on the temperature reported by the processor's Thermal Diode. If the diode temperature is greater than or equal to $T_{control}$, then the processor case temperature must remain at or below the temperature as specified by the thermal profile in the processor datasheet. If the diode temperature is less than $T_{control}$ then the case temperature is permitted to exceed the thermal profile, but the diode temperature must remain at or below $T_{control}$. Systems that implement fan speed control must be designed to take this into account. Systems that do not alter the fan speed only need to guarantee the case temperature meets the thermal profile specifications. For more information on $T_{control}$ and the thermal profile, refer to the *Intel® Pentium® 4 Processor on 90 nm Process Datasheet* and the *Intel® Pentium® 4 Processor on 90 nm Process Thermal and Mechanical Design Guidelines*.

4.3 Thermal Solution Requirements

The thermal performance required for the heatsink is determined by calculating the case-to-ambient thermal resistance, Ψ_{CA} . This is a basic thermal engineering parameter that may be used to evaluate and compare different thermal solutions. For this particular processor an example of how Ψ_{CA} is calculated for the 3.0 GHz processor is shown in [Equation 3](#).

Equation 3. Case-to-Ambient Thermal Resistance

$$\Psi_{CA} = \frac{T_{c\ max} \text{ } ^\circ\text{C} - T_{LA} \text{ } ^\circ\text{C}}{TDP(W)} = \frac{69^\circ\text{C} - 38^\circ\text{C}}{89\text{W}} = 0.348 \frac{^\circ\text{C}}{\text{W}}$$

In this calculation, $T_{C\ max}$ and TDP are constant, while Ψ_{CA} may vary according to the local ambient temperature (T_{LA}). [Table 3](#) shows an example of required thermal resistances for the thermal solution at various local ambient temperatures. The table uses the TDP from the *Intel® Pentium® 4 Processor on 90 nm Process Datasheet* and the $T_{C\ max}$ based on the thermal profile at TDP.

These numbers are subject to change, and in case of conflict the *Intel® Pentium® 4 Processor on 90 nm Process Datasheet* supersedes the TDP and $T_{C\ max}$ specifications in this document.

Table 3. Processor Thermal Specifications

Intel® Pentium® 4 Processor on 90 nm Process for Embedded Applications			Required Thermal Resistance, Ψ_{CA} of Thermal Solution at $T_A =$		
Frequency (GHz)	TDP (W)	Tcase max	43.3	40	35
3.0	89	69.11	0.290	0.327	0.383
3.4	89	69.11	0.290	0.327	0.383

NOTE: The Ψ_{CA} performance given above refers to sea level conditions and does not take into account altitude effects such as different air density and overall heat capacity. This often leads to some degradation in thermal solution performance compared to what is obtained at sea level, with lower fan performance and higher surface temperatures. Companies designing products that must function reliably at high altitude, typically 1,500 m (5,000 ft.) or more, must adapt the thermal performance targets accordingly. The system designer needs to account for the altitude effects in the overall system thermal design to ensure that the requirement for the processor is met at the targeted altitude.

Figure 11 further illustrates the required thermal performance for the Intel® Pentium® 4 Processor on 90 nm Process at 3.0 GHz at different operating ambient temperatures. The thermal solution chosen to cool the processor must have a case-to-ambient thermal resistance less than the values shown for the given local ambient temperature.

Figure 11. Thermal Resistance Values for Various Operating Temperatures

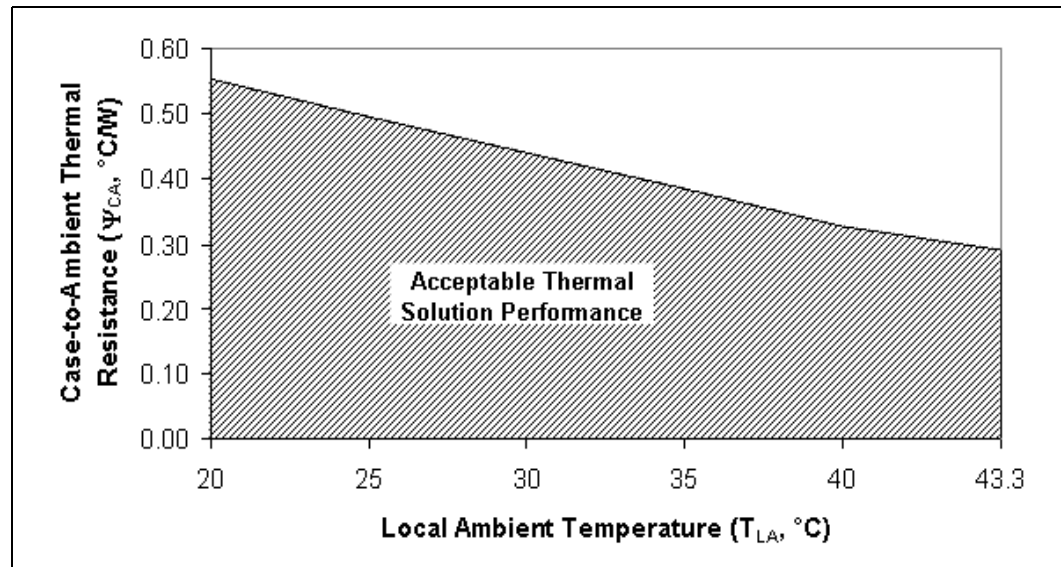

4.4 Recommended Thermal Solutions

4.4.1 Desktop/ATX Form Factor

The Intel Embedded IA division (EID) is enabling the following active thermal solutions for the Intel® Pentium® 4 Processor on 90 nm Process in the ATX form factor. Table 4 lists these solutions along with suppliers

Table 4. Recommended Thermal Solutions

Heatsink Manufacturer	Intel Part Number
Sanyo-Denki	C33218

This is the standard thermal solution enabled by Intel’s Reseller’s Products Group. For more information, refer to the *Intel® Pentium® 4 Processor on 90 nm Process Thermal and Mechanical Design Guidelines*.

4.4.2 1U Reference Thermal Solution

Intel has designed a reference thermal solution for the Intel® Pentium® 4 Processor on 90 nm Process processor in the 1U form factor. This solution uses dense fin heat sink technology combined with high speed airflow devices. This thermal solution has a relatively high pressure drop and requires an airflow source that can provide the necessary amount of airflow to meet the component and system thermal performance targets. The performance for this heatsink when used in combination with a high speed blower and Shin-Etsu* G751 thermal grease, has shown a $\Psi_{CA} = 0.33^{\circ} \text{C/W}$ at 15.5 CFM and 0.60 in_{water}. However, the final intended thermal solution including, heatsink, TIM and attach mechanism must be validated by system integrators. In addition to the high speed airflow source, this heatsink requires 100 percent of the airflow to be ducted through the fins in order to prevent heatsink bypass. A mechanical drawing of the enabled thermal solution can be seen in Figure 17 of the appendix.

The primary and secondary side volumetric constraints for the 1U thermal solution can be seen in Section 2.1.2, “Motherboard Volumetric Constraint Requirements” on page 12. This thermal solution is attached to the processor package with the use of spring loaded fasteners attached to a backplate on the bottom side of PCB.

Developers who want to design thermal solutions for the Intel® Pentium® 4 Processor on 90 nm Process in the 1U server form factor need to ensure that it meets the thermal requirement stated in Section 4.3, “Thermal Solution Requirements” on page 28. They must also adhere to the standard mechanical volumetric constraints as stated in Section 2.1.2, “Motherboard Volumetric Constraint Requirements” on page 12.

Figure 12 illustrates the z-height constraints of the 1U form factor. This mechanical stackup is based on the Server System Infrastructure Specifications. These specifications may be viewed at <http://www.ssiforum.org>.

Figure 12. 1U Thermal Solution Z-Height Constraints

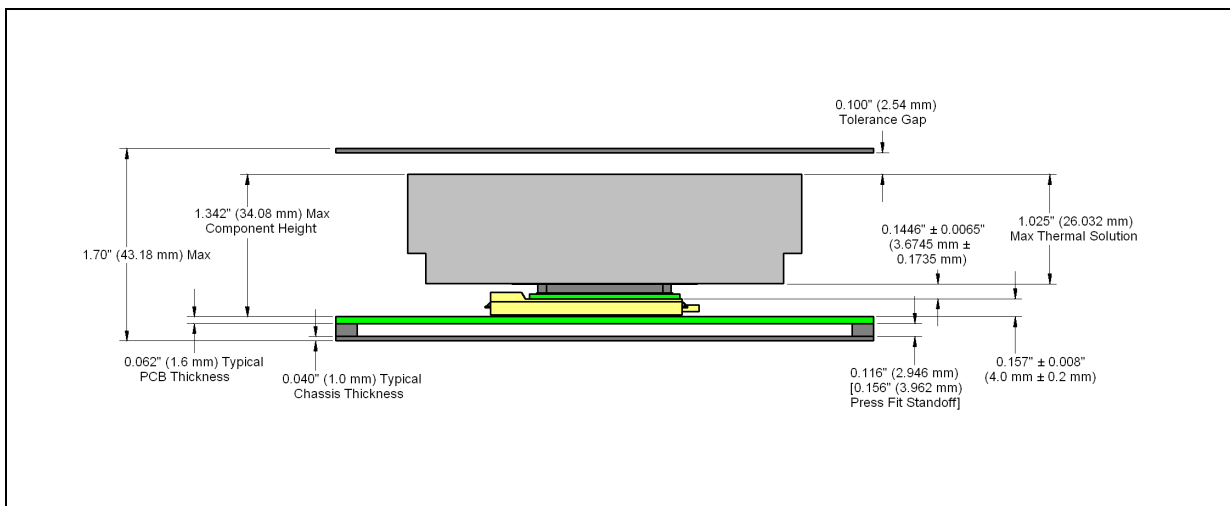

4.4.3 2U Reference Thermal Solution

Intel has designed a reference thermal solution for the Intel® Pentium® 4 Processor on 90 nm Process for Embedded Applications in the 2U form factor. This solution uses dense fin heat sink technology combined with high speed airflow devices. This thermal solution has a relatively high pressure drop and requires an airflow source that can provide the necessary amount of airflow to meet the component and system thermal performance targets. The performance for this heatsink when used in combination with a high speed fan and Shin-Etsu* G751 thermal grease, has shown a $\Psi_{CA} = .315^{\circ} \text{C/W}$ at 34 CFM and 0.357 in_{water}. However, the final intended thermal solution including, heatsink, TIM and attach mechanism must be validated by system integrators. In addition to the high speed airflow source, this heatsink requires 100% of the airflow to be ducted through the fins in order to prevent heatsink bypass. A mechanical drawing of the enabled thermal solution can be seen in Figure 18.

The primary and secondary side volumetric constraints for the 2U thermal solution can be seen in Section 2.1.2, “Motherboard Volumetric Constraint Requirements” on page 12. This thermal solution is attached to the processor package with the use of spring loaded fasteners attached to a backplate on the bottom side of PCB. The entire 2U assembly including backplate, PCB, Processor, heatsink and fasteners can be seen in Figure 13. The same retention mechanism is used for both the 1U and 2U solutions.

Figure 13 illustrates z-height constraints of the 2U form factor. This mechanical stackup is based on the Server System Infrastructure Specifications. These specifications may be viewed at <http://www.ssiforum.org>.

Figure 13. 2U Thermal Solution Z-Height Constraints

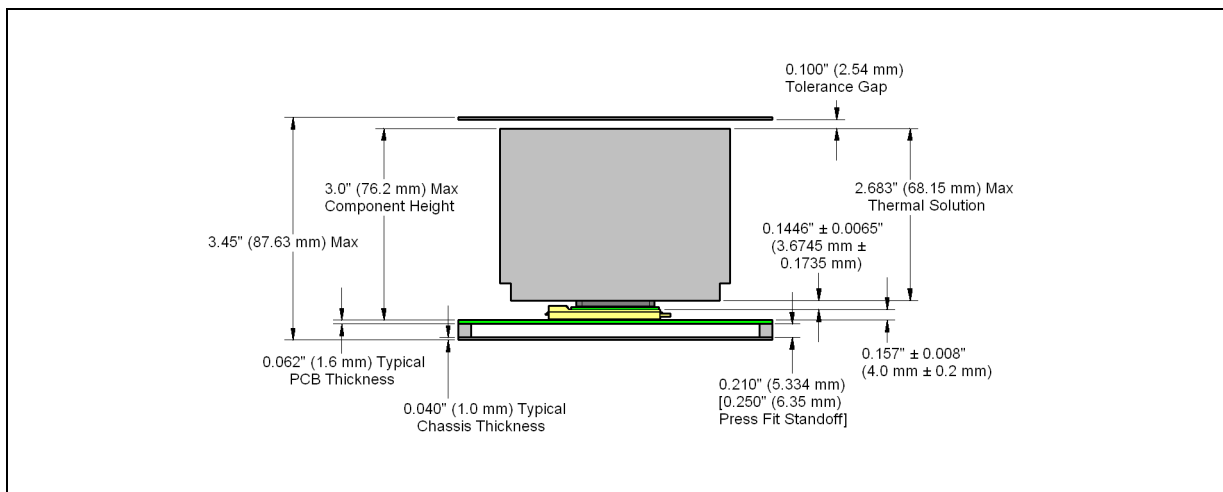
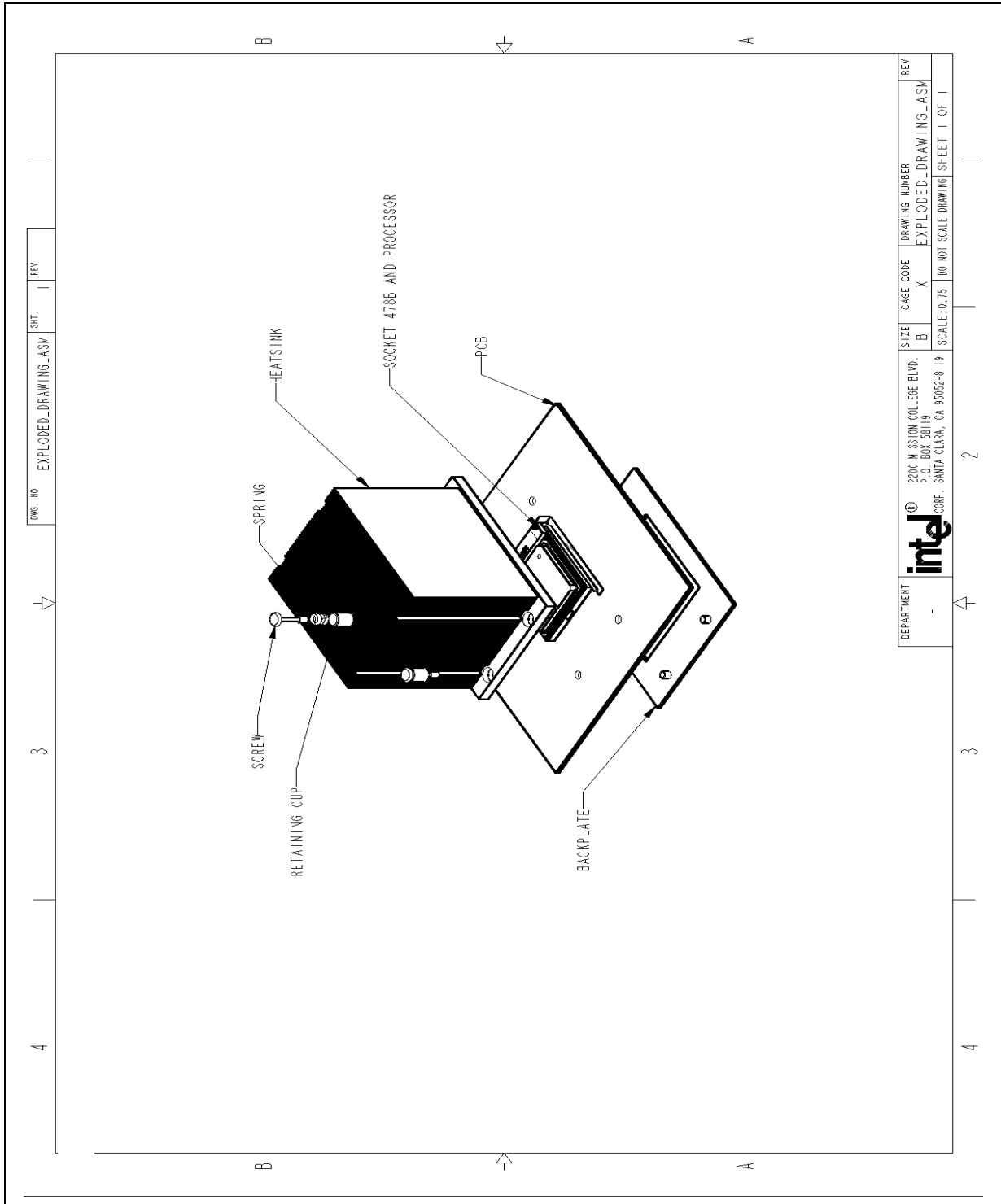

Figure 14 illustrates an exploded view of the 2U reference thermal solution.

Figure 14. 2U Reference Thermal Solution: Exploded View



4.5 Interface to Package Requirements

The Intel[®] Pentium[®] 4 Processor on 90 nm Process is packaged in a Flip-Chip Pin Grid Array (FC-mPGA4) package technology. Refer to the *Intel[®] Pentium[®] 4 Processor on 90 nm Process Datasheet* for detailed mechanical specifications of the 478-pin package.

The package includes an integrated heat spreader (IHS). The IHS spreads non-uniform heat from the die to the top of the IHS, out of which the heat flux is more uniform and on a larger surface area. This allows more efficient heat transfer out of the package to an attached cooling device.

Note: Do not assume that the processor power is dissipated uniformly on the IHS. In particular, when validating a thermal solution, an Intel[®] Pentium[®] 4 Processor on 90 nm Process thermal test vehicle shall be used, and a correlation to real parts applied to the results. Refer to the *Intel[®] Pentium[®] 4 Processor on 90 nm Process Thermal and Mechanical Design Guidelines*.

The IHS is designed to be the interface for mounting a heatsink. Details may be found in the *Intel[®] Pentium[®] 4 Processor on 90 nm Process Datasheet*.

The processor connects to the motherboard through a ZIF surface mount socket. The socket is described in the *Intel[®] Pentium[®] 4 Processor, 478-Pin Socket (mPGA478B) Design Guidelines*.

To facilitate customer assembly and ensure proper alignment and cooling performance, the heatsink base must be designed for symmetrical assembly. Refer to [Section 2.1.3.3, “Additional Requirements for Solutions Using Reference ATX Heatsink and Reference Clip”](#) on page 19 for further information on the interface to the motherboard.

It is not recommended to use any portion of the interposer as a mechanical reference or load-bearing surface in either static or dynamic compressive load conditions.

4.6 Thermal Interface Material Requirements

All thermal interface materials must be sized and positioned on the heatsink base in a way that ensures that the entire processor IHS area is covered. It is important to compensate for heatsink-to-processor attachment positional alignment when selecting the proper thermal interface material size.

Note: When a pre-applied thermal interface material is specified, it may have a protective application tape. This tape must be removed prior to heatsink attachment.

As overall performance of the processor cooling solution becomes more and more demanding, TIM performance contribution must be carefully studied. In selecting the TIM, consider the following (not an extended list):

- Compatibility with high volume manufacturing and assembly for installation.
- Minimal adhesion of the TIM that may create a strong bond between the heatsink and the package, creating the following impacts:
 - Potential package pullout from the actuated socket when removing the heatsink from the processor for rework and servicing.
 - Increased risk of package pullout from socket during shock and vibration events.
- Load needed on the heatsink/processor/socket assembly to ensure TIM performance (refer to [Section 4.7](#) for package load specifications).

4.7 Package and Socket Load Specifications

Refer to the *Intel® Pentium® 4 Processor on 90 nm Process Datasheet* for additional information.

Table 5. Package Static and Dynamic Load Specifications

Parameter	Minimum	Maximum	Notes
Static	89 N [20 lbf]	445 N [100 lbf]	1, 2, 3
Dynamic		890 N [200 lbf]	1, 3, 4
Transient		667 N [150 lbf]	1, 3, 5

NOTES:

1. These specifications apply to uniform compressive loading in a direction normal to the processor IHS.
2. This is the maximum force that can be applied by a heatsink retention clip. The clip must also provide the minimum specified load on the processor package.
3. These specifications are based on limited testing for design characterization. Loading limits are for the package only and do not include limits of the processor socket.
4. Dynamic loading is defined as an 11 ms duration average load superimposed on the static load requirement.
5. Transient loading is defined as a 2 second duration peak load superimposed on the static load requirement, representative of loads experienced in the package during heatsink installation.

These load limits shall not be exceeded during heatsink installation, removal, mechanical stress testing, or standard shipping conditions. For example, when a compressive static load is necessary to ensure thermal performance of the thermal interface material between the heatsink base and the IHS, this compressive static load shall not exceed 100 lbf.

The heatsink mass may also add additional dynamic compressive load to the package during a shock. Amplification factors due to the impact force during shock have to be taken into account in dynamic load calculations. The total combination of dynamic and static compressive load shall not exceed 200 lbf during a vertical shock. For example, with a 1 lbf heatsink, an acceleration of 50 g during an 11 ms shock results approximately in a 100 lbf dynamic load on the processor package. If, in addition, a 100 lbf static load is applied on the heatsink for thermal performance of the thermal interface material and/or for mechanical reasons, the processor/heatsink assembly received a total load of 200 lbf for the package.

This page intentionally left blank.



5.0 Thermal Metrology for the Intel® Pentium® 4 Processor on 90 nm Process for Embedded Applications Processor

The thermal metrology for the Intel® Pentium® 4 Processor on 90 nm Process is outlined in the *Intel® Pentium® 4 Processor on 90 nm Process Thermal and Mechanical Design Guidelines*. Refer to this document when performing validation on thermal solutions for the Intel® Pentium® 4 Processor on 90 nm Process.



This page intentionally left blank.

6.0 Thermal Test Vehicle Information

The Intel® Pentium® 4 Processor on 90 nm Process Thermal Test Vehicle (TTV) is a FC-mPGA4 package assembled with a thermal test die. The cooling capability of a specific system thermal solution may be assessed using the thermal tool in a system environment. The TTV is designed for use in platforms targeted for the Intel® Pentium® 4 Processor on 90 nm Process.

For more information on the TTV and user's guide, see the *Intel® Pentium® 4 Processor on 90 nm Process Thermal and Mechanical Design Guidelines*.



This page intentionally left blank.

7.0 Thermal Monitor

An on-die thermal management feature called the Intel Thermal Monitor is available on the Intel® Pentium® 4 Processor on 90 nm Process. It provides a thermal management approach to support continued increases in processor frequency and performance. Using a highly accurate on-die temperature sensing circuit and a fast-acting Temperature Control Circuit (TCC), the processor may rapidly initiate thermal management control. The Intel Thermal Monitor may reduce cooling solution cost by allowing designs to target TDP instead of maximum power without impacting processor reliability or performance. For more information on the Intel Thermal Monitor, refer to the *Intel® Pentium® 4 Processor on 90 nm Process Thermal and Mechanical Design Guidelines* and the *Intel® Pentium® 4 Processor on 90 nm Process Datasheet*.

This page intentionally left blank.

8.0 Vendor Data

Table 6. Vendor Contact Information

Component	Supplier	Contact	Phone	email
478-pin Socket	Foxconn	Julia Jiang	408-919-6178	juliaj@foxconn.com
	Tyco/AMP Incorporated	Ralph Spayd	717-592-7653	respayd@tycoelectronics.com
ATX/Desktop Heat Sinks	Sanyo-Denki	Haruhiko (Harry) Kawasumi	301-783-5430	haruhiko@sanyo-denki.com
1U and 2U Heatsinks, Reference No. EID-PSC-CUCU-001-1U and EID-PSC-CUAL-001-2U	CoolerMaster	Wendy Lin	909-673-9880 ext 102	wendy@coolermaster.com
	Foxconn	Jack Chen	714-626-1233	jack.chen@foxconn.com
Thermal Interface Materials	Shin-Etsu Micro Si, Inc.		480-893-8898	www.microsi.com
CPU Retention Mechanism	Foxconn	Julia Jiang	408-919-6178	juliaj@foxconn.com
	Nextron	Johnson Lee	886-2-8691-8238 ext. 248	Johns@nextron.com.tw
	Wieson	Rick Lin	886-2-2647-1896	rick@wieson.com
	CCI	Monica Chih	886-2-2995-2666 ext 8	monica_chih@ccic.com.tw
Heat Sink Attach Clip	Foxconn	Julia Jiang	408-919-6178	juliaj@foxconn.com
	TecStar Manufacturing	Christine Withers	262-255-5790	christine.withers@mgstech.com

This page intentionally left blank.

Appendix A Mechanical Drawings

Note: Mechanical drawings are found on the following pages.

Figure 15. Retention Mechanism 1

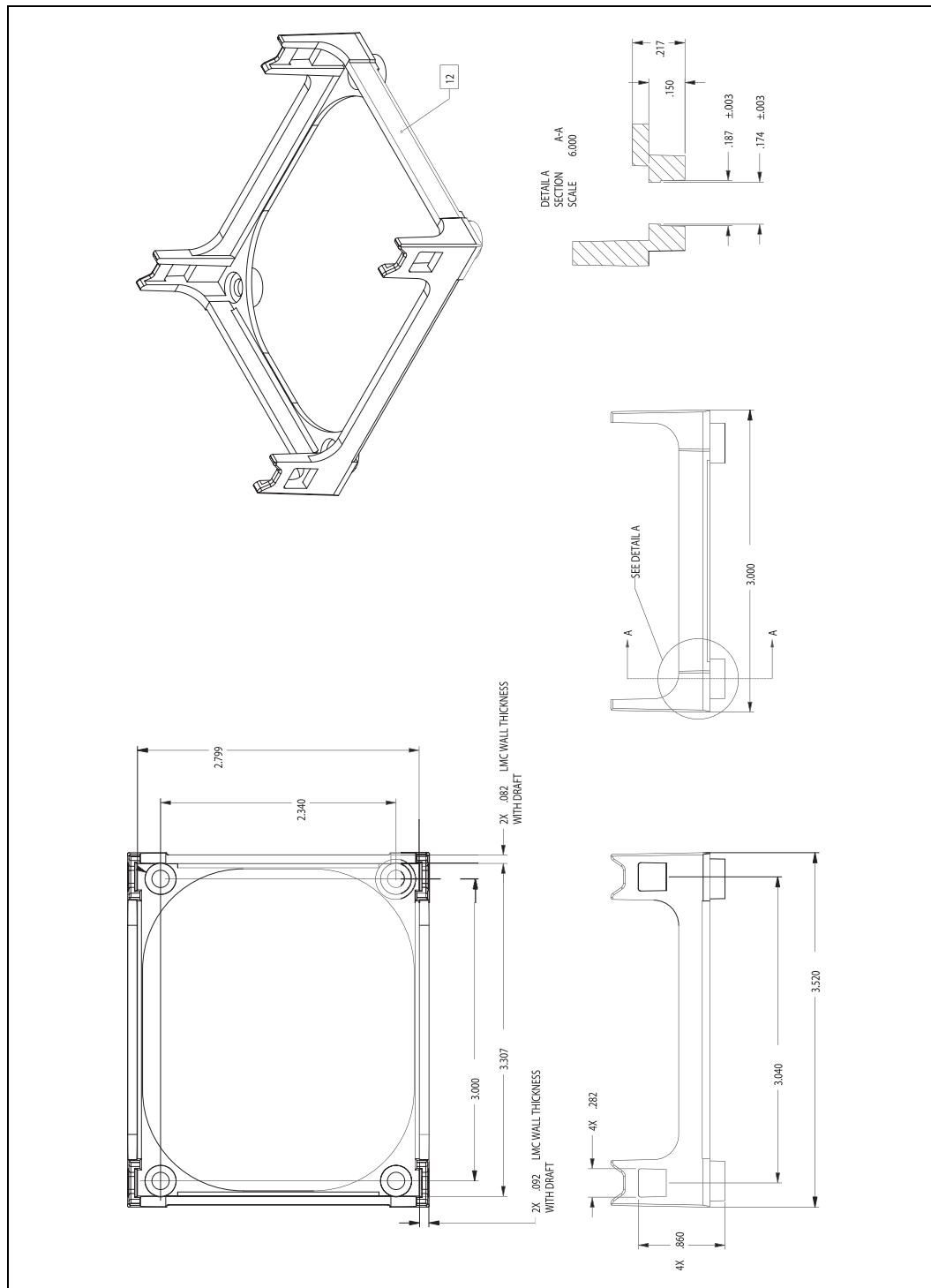

Figure 16. Retention Mechanism 2

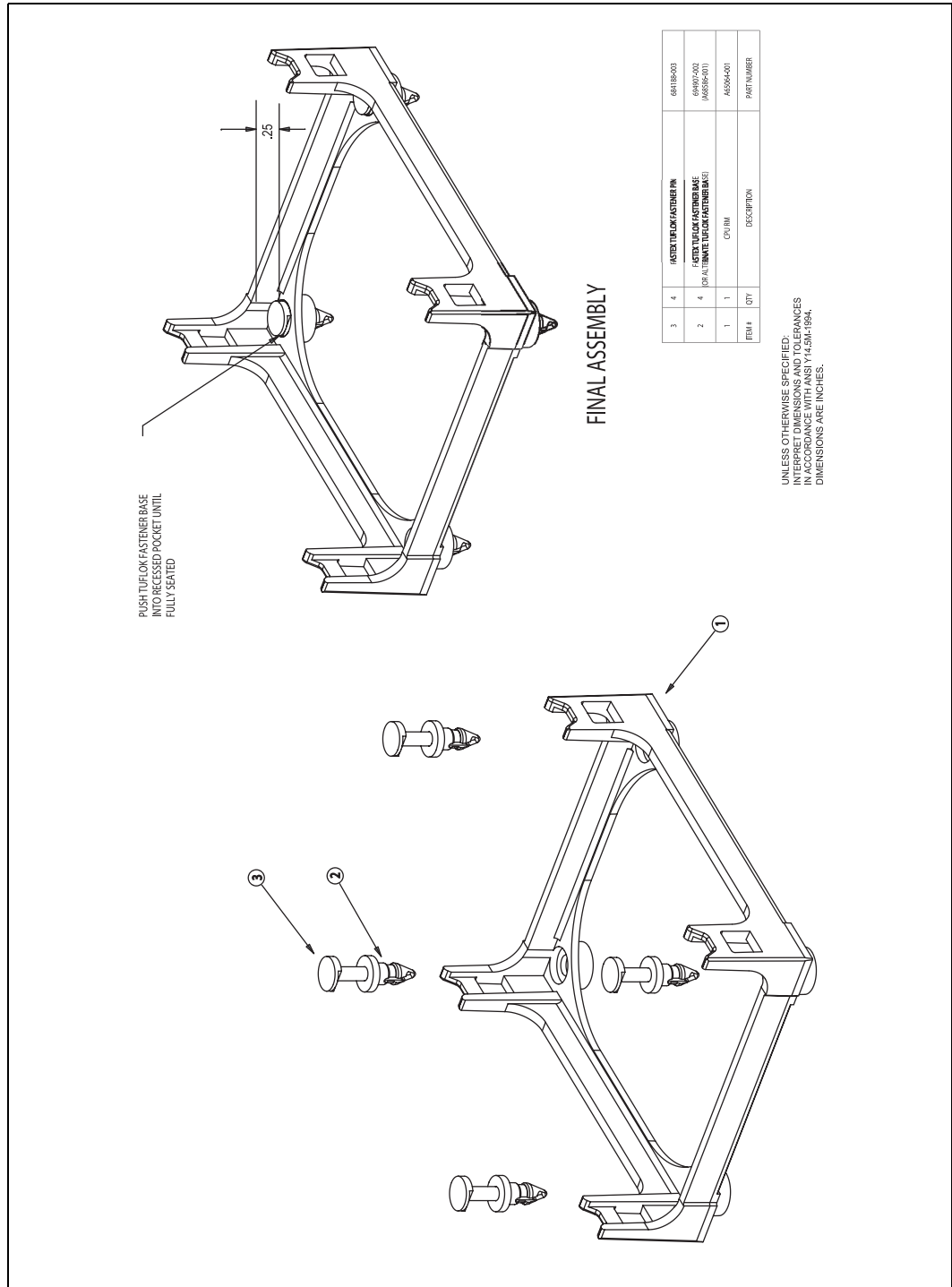

Figure 17. 1U Reference Thermal Solution Heatsink

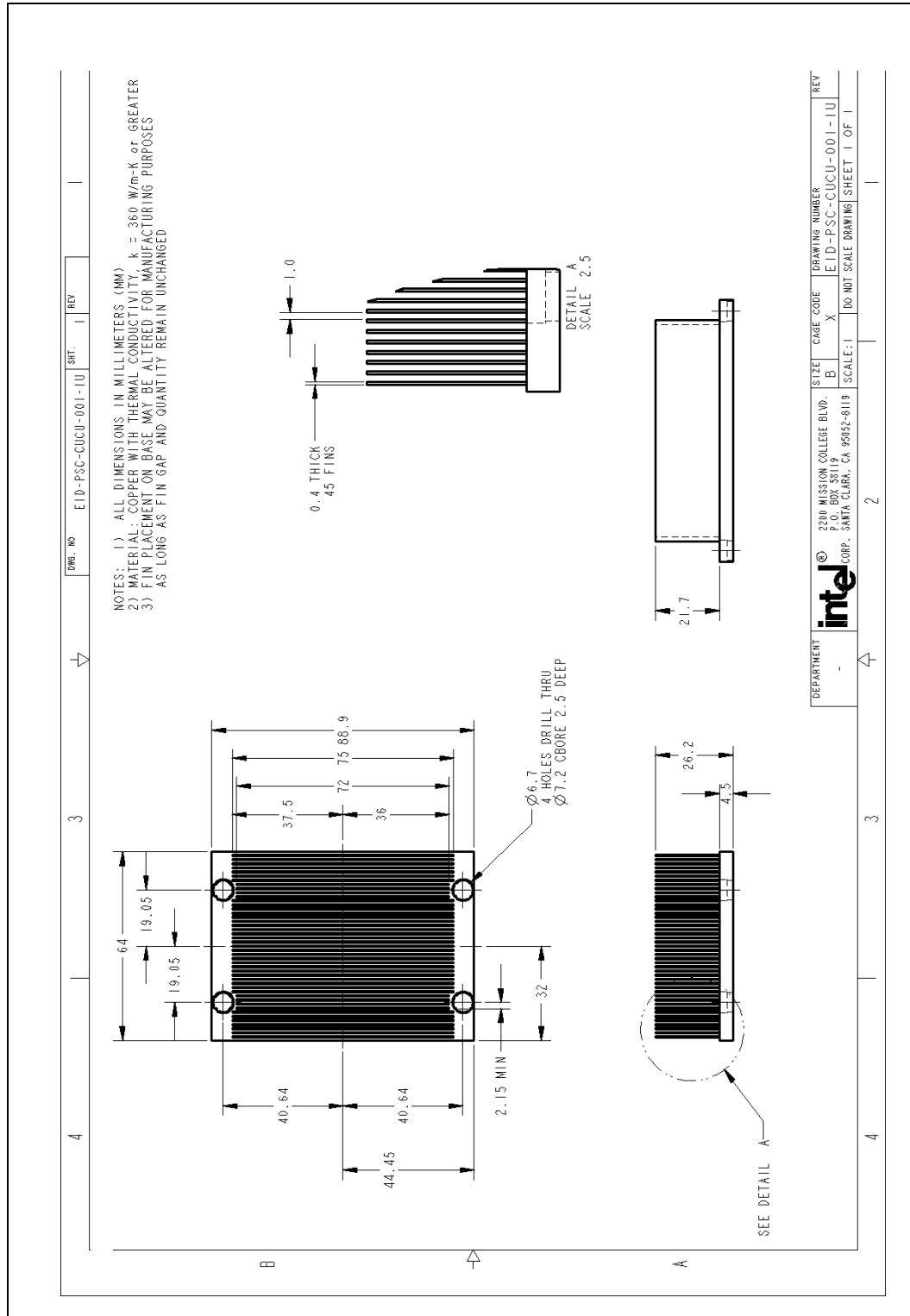
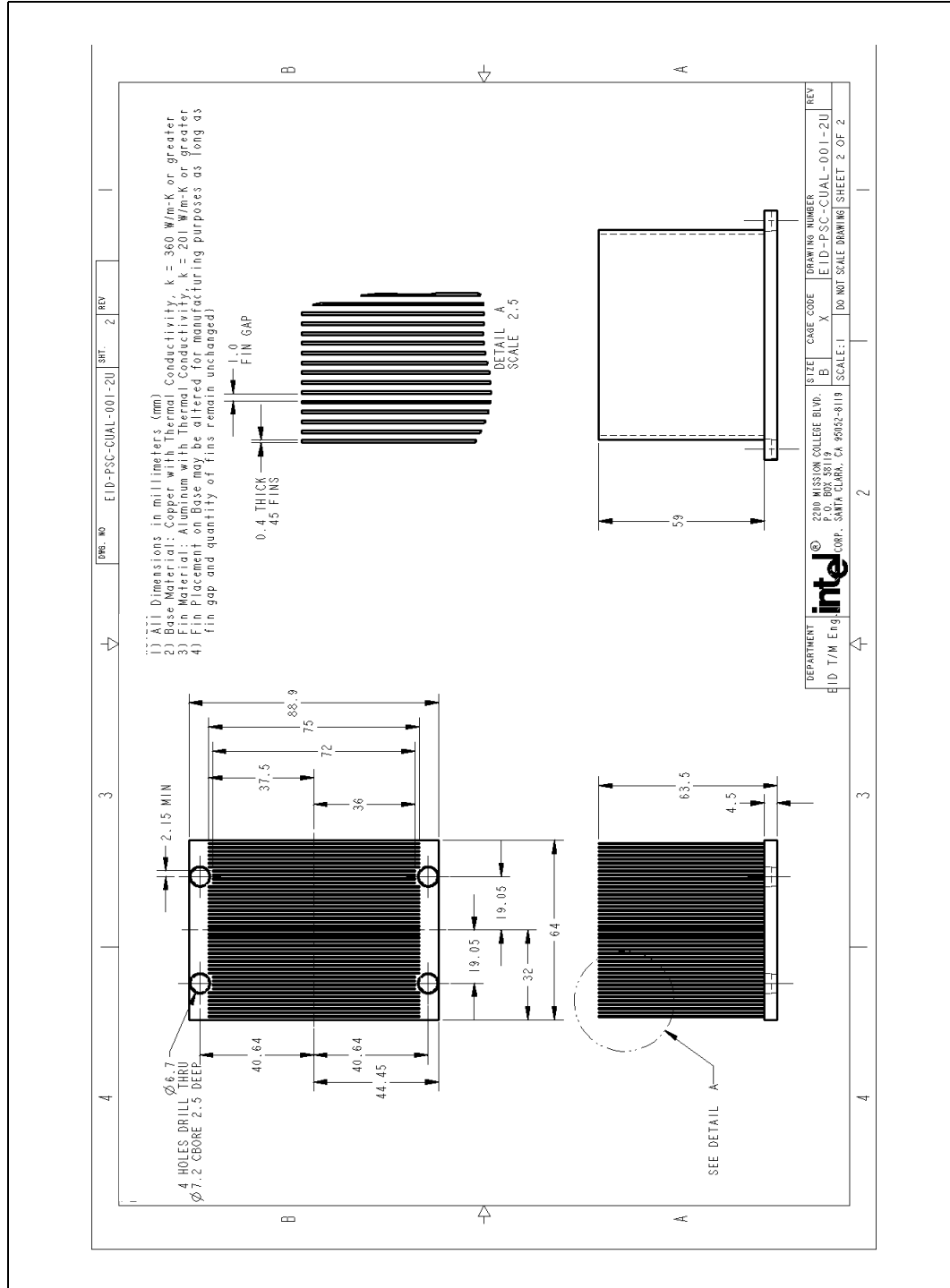

Figure 18. 2U Reference Thermal Solution Heatsink



This page intentionally left blank.