

Intel® IXDPG425 Network Gateway Reference Platform

A Voice/Wireless Gateway Reference Design

Product Overview

The Intel® IXDPG425 Network Gateway Reference Platform provides an easy to use platform with complete schematics, bill of materials (BOM) and PCB design source files to provide a significant improvement in time to market for developers of leading edge gateway products.

The Intel® IXDPG425 Reference Platform demonstrates the scalability of the Intel® IXP425 network processor as a solution for a wide range of applications from wireless residential gateways to security solutions providing VPN termination, to a complete Voice over IP (VoIP) solution for the small office.

Product Highlights

The Intel IXDPG425 Network Gateway Reference Platform accelerates time-to-market by providing the user with a complete hardware solution combined with the availability of turnkey applications or development environments.

- Complete schematic source files and PCB Gerbers to assist in design customization (Available from your local Intel Sales Representative)
- Complete VoIP gateway implementation for voice and data CPE applications

- On board Intel IXP425 533 MHz network processor
- Compact 6"x9" design
- 32 MB SDRAM (pad-out for up to 128 MB)
- 16 MB Socketed FLASH memory (pad-out for up to 32 MB)
- Available demonstration applications—For the latest third-part applications, go to <http://developer.intel.com/design/network/products/npfamily/ixdpg425.htm>

Key Interfaces

- Voice: 4 FXS ports (RJ11) for analog phone connections
- 1 PSTN failover port (RJ11)
- LAN: Switched Ethernet 4–10/100 Ports
- WAN: 1–10/100 Ethernet port for broadband connectivity
- WAN: UTOPIA-2 mezzanine connection for use with xDSL
- mPCI—2 available slots (32 bit/33 MHz)
- 1 RS-232 Interface
- USB 2.0: 2 host ports (EHCI) using NEC* solution
- USB 1.1: 1 device port
- 9 Status LEDs
- JTAG
- Power: Input: 100–250v, 50/60 Hz, 0.8A Output: 12vdc, 2.5A

Figure 1. Intel® IXDPG425 Network Gateway Reference Platform

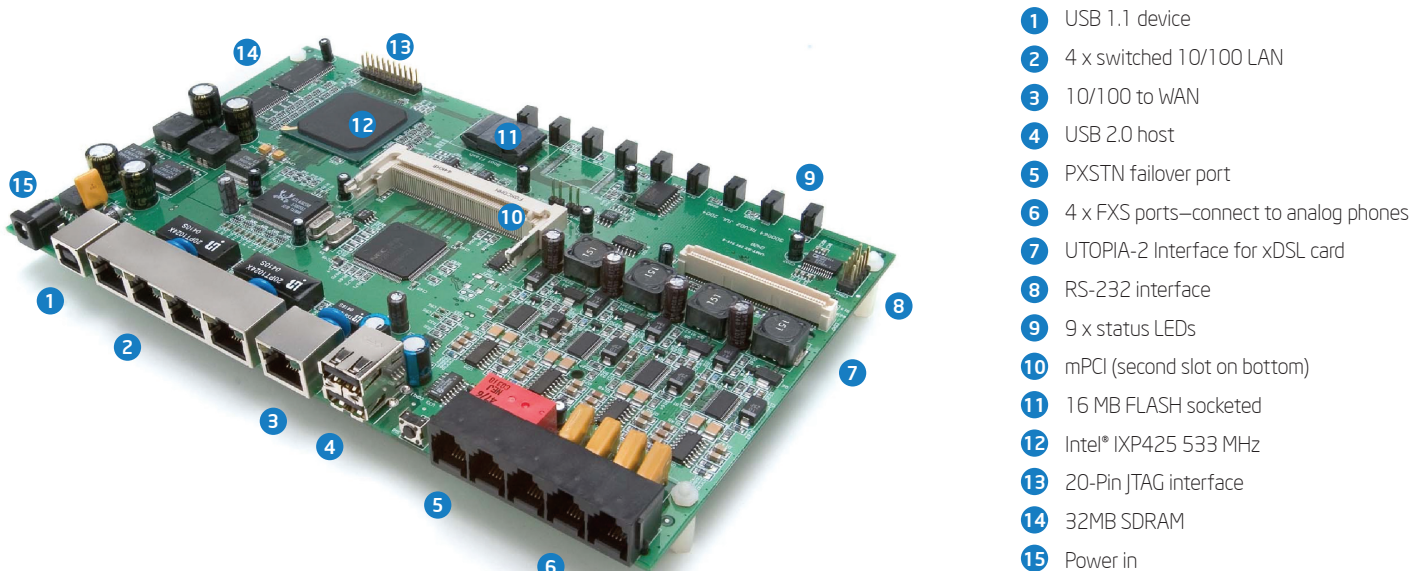

- 1 USB 1.1 device
- 2 4 x switched 10/100 LAN
- 3 10/100 to WAN
- 4 USB 2.0 host
- 5 PSTN failover port
- 6 4 x FXS ports—connect to analog phones
- 7 UTOPIA-2 Interface for xDSL card
- 8 RS-232 interface
- 9 9 x status LEDs
- 10 mPCI (second slot on bottom)
- 11 16 MB FLASH socketed
- 12 Intel® IXP425 533 MHz
- 13 20-Pin JTAG interface
- 14 32MB SDRAM
- 15 Power in

Supported Software

The Intel® IXDPG425 Reference Platform provides hardware building blocks coupled with third-party software solutions to create a complete reference design for various targeted market segments. Demonstration applications for WLAN Access Points, VoIP Gateway, Network Attached Storage, Print Server, and VPN Security are available for use on the IXDPG425. For the latest list of applications, go to <http://developer.intel.com/design/network/products/npfamily/ixdpg425.htm>

Voice Features

- Analog telephone interface
- 4 FXS ports
- 1 PSTN failover port
- Software codecs via third-party applications that utilize Intel® IXP400 DSP software

Intel® IXDPG425 Reference Platform Includes:

- 1 IXDPG425 Baseboard
- 2 Ethernet cables
- 1 USB cable
- 1 Cat 3 cable with male RJ11 connectors
- 1 Brick power supply
- 1 Installed flash chip with bootloader code
- 1 10-pin to DB9 conversion cable

Ordering Information

- Contact your local Intel sales representative to order

Figure 2. Block Diagram for the Intel® IXDPG425 Network Gateway Reference Platform

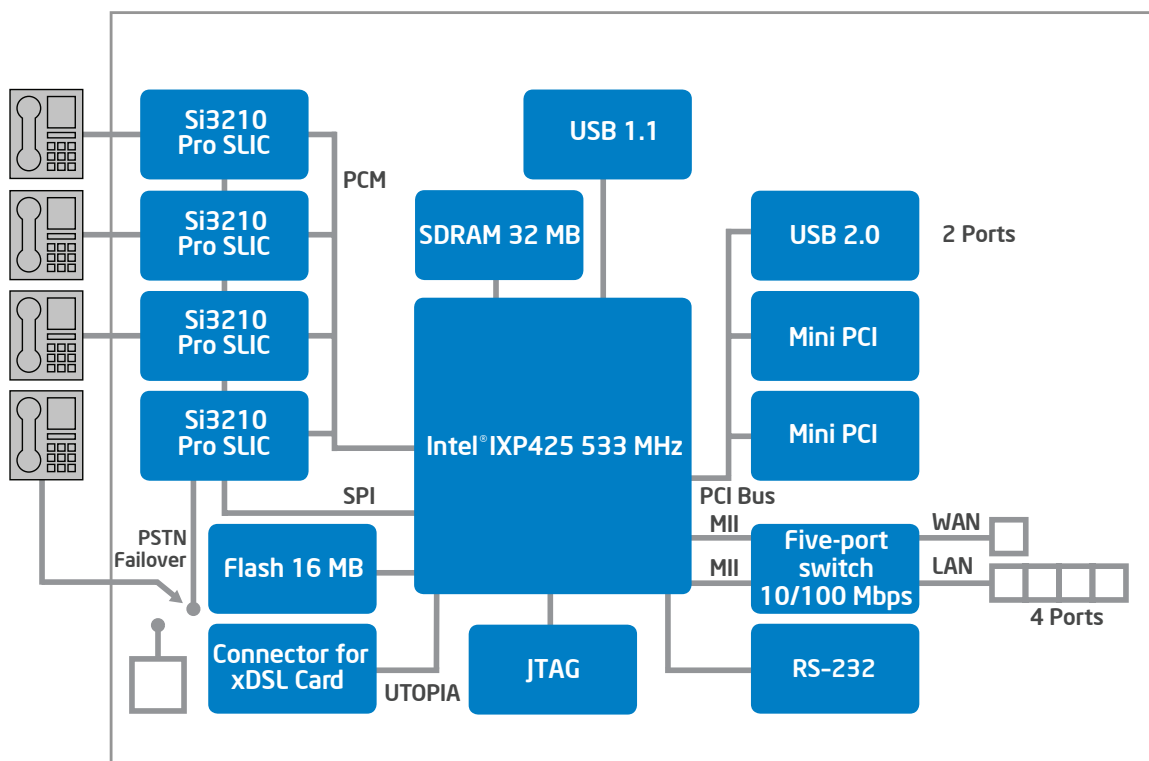

INFORMATION IN THIS DOCUMENT IS PROVIDED IN CONNECTION WITH INTEL® PRODUCTS. EXCEPT AS PROVIDED IN INTEL'S TERMS AND CONDITIONS OF SALE FOR SUCH PRODUCTS, INTEL ASSUMES NO LIABILITY WHATSOEVER, AND INTEL DISCLAIMS ANY EXPRESS OR IMPLIED WARRANTY RELATING TO SALE AND/OR USE OF INTEL PRODUCTS, INCLUDING LIABILITY OR WARRANTIES RELATING TO FITNESS FOR A PARTICULAR PURPOSE, MERCHANTABILITY, OR INFRINGEMENT OF ANY PATENT, COPYRIGHT, OR OTHER INTELLECTUAL PROPERTY RIGHT. INTEL MAY MAKE CHANGES TO SPECIFICATIONS, PRODUCT DESCRIPTIONS, AND PLANS AT ANY TIME, WITHOUT NOTICE.

Intel Corporation may have patents or pending patent applications, trademarks, copyrights, or other intellectual property rights that relate to the presented subject matter. The furnishing of documents and other materials and information does not provide any license, express or implied, by estoppel or otherwise, to any such patents, trademarks, copyrights, or other intellectual property rights. Intel products are not intended for use in medical, life saving, life sustaining, critical control or safety systems, or in nuclear facility applications. The Intel® IXP425 network processor may contain design defects or errors known as errata, which may cause the product to deviate from published specifications. Current characterized errata are available upon request.

Intel, the Intel logo, Leap ahead, the Leap ahead. logo, and Intel XScale are trademarks or registered trademarks of Intel Corporation or its subsidiaries in the United States and other countries.

*Other names and brands may be claimed as the property of others.

Copyright © 2007 Intel Corporation. All rights reserved.

0407/KSC/QUA/PDF

♻️ Please Recycle

305303-002US

