

Intel® Desktop Board D915PGN/D915PSY/ D915PCY/D915PCM Product Guide

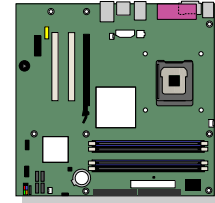
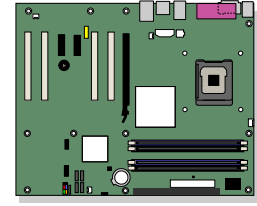

Order Number: C64156-001

Revision History

Revision	Revision History	Date
-001	First release of the Intel® Desktop Board D915PGN/D915PSY/D915PCY/D915PCM Product Guide.	June 2004

If an FCC declaration of conformity marking is present on the board, the following statement applies:

FCC Declaration of Conformity

This device complies with Part 15 of the FCC Rules. Operation is subject to the following two conditions: (1) this device may not cause harmful interference, and (2) this device must accept any interference received, including interference that may cause undesired operation.

For questions related to the EMC performance of this product, contact:

Intel Corporation, 5200 N.E. Elam Young Parkway, Hillsboro, OR 97124
1-800-628-8686

This equipment has been tested and found to comply with the limits for a Class B digital device, pursuant to Part 15 of the FCC Rules. These limits are designed to provide reasonable protection against harmful interference in a residential installation. This equipment generates, uses, and can radiate radio frequency energy and, if not installed and used in accordance with the instructions, may cause harmful interference to radio communications. However, there is no guarantee that interference will not occur in a particular installation. If this equipment does cause harmful interference to radio or television reception, which can be determined by turning the equipment off and on, the user is encouraged to try to correct the interference by one or more of the following measures:

- Reorient or relocate the receiving antenna.
- Increase the separation between the equipment and the receiver.
- Connect the equipment to an outlet on a circuit other than the one to which the receiver is connected.
- Consult the dealer or an experienced radio/TV technician for help.

Any changes or modifications to the equipment not expressly approved by Intel Corporation could void the user's authority to operate the equipment.

Canadian Department of Communications Compliance Statement

This digital apparatus does not exceed the Class B limits for radio noise emissions from digital apparatus set out in the Radio Interference Regulations of the Canadian Department of Communications.

Le présent appareil numérique n'émet pas de bruits radioélectriques dépassant les limites applicables aux appareils numériques de la classe B prescrites dans le Règlement sur le brouillage radioélectrique édicté par le ministère des Communications du Canada.

Disclaimer

Information in this document is provided in connection with Intel® products. No license, express or implied, by estoppel or otherwise, to any intellectual property rights is granted by this document. Except as provided in Intel's Terms and Conditions of Sale for such products, Intel assumes no liability whatsoever, and Intel disclaims any express or implied warranty, relating to sale and/or use of Intel products including liability or warranties relating to fitness for a particular purpose, merchantability, or infringement of any patent, copyright or other intellectual property right. Intel products are not intended for use in medical, life saving, or life sustaining applications. Intel may make changes to specifications and product descriptions at any time, without notice.

Desktop Board D915PGN/D915PSY/D915PCY/D915PCM may contain design defects or errors known as errata which may cause the product to deviate from published specifications. Current characterized errata are available on request.

Contact your local Intel sales office or your distributor to obtain the latest specifications and before placing your product order.

Copies of documents which have an ordering number and are referenced in this document, or other Intel literature, may be obtained from Intel Corporation by going to the World Wide Web site at: <http://www.intel.com/> or by calling 1-800-548-4725.

Intel, Pentium, and Celeron are registered trademarks of Intel Corporation or its subsidiaries in the United States and other countries.

* Other names and brands may be claimed as the property of others.

Copyright © 2004, Intel Corporation. All rights reserved.

Preface

This Product Guide gives information about board layout, component installation, BIOS update, and regulatory requirements for Intel® Desktop Board D915PGN/D915PSY/D915PCY/D915PCM.

Intended Audience

The Product Guide is intended for technically qualified personnel. It is not intended for general audiences.

Information Layout

The chapters in this Product Guide are arranged as follows:

- [1 Desktop Board Features](#): a summary of product features
- [2 Installing and Replacing Desktop Board Components](#): instructions on how to install the desktop board and other hardware components
- [3 BIOS](#): instructions on how to update the BIOS
- [4 Desktop Board Resources](#): information about connectors and desktop board resources
- [A Error Messages and Indicators](#): information about BIOS error messages and beep codes
- [B Regulatory Compliance](#): safety and EMC regulations, product certification

Conventions

The following conventions are used in this manual:



WARNING

Warnings indicate conditions that, if not observed, can cause personal injury.



CAUTION

Cautions warn the user about how to prevent damage to hardware or loss of data.



NOTE

Notes call attention to important information.

Terminology

The table below gives descriptions to some common terms used in the product guide.

Term	Description
GB	Gigabyte (1,073,741,824 bytes)
GHz	Gigahertz (one billion hertz)
KB	Kilobyte (1024 bytes)
MB	Megabyte (1,048,576 bytes)
Mbit	Megabit (1,048,576 bits)
MHz	Megahertz (one million hertz)

Box Contents

- Intel Desktop Board
- I/O shield
- One IDE cable
- Two Serial ATA cables
- One diskette drive cable
- Quick Reference Guide
- Configuration and battery caution statement label
- Intel® Express Installer CD-ROM

Contents

1 Desktop Board Features

Manufacturing Options	11
Supported Operating Systems	11
Desktop Board Components	12
Processor	16
Main Memory	17
Intel® 915P Express Chipset	18
Audio Subsystem	18
Input/Output (I/O) Controller	19
LAN Subsystem (Optional)	19
LAN Subsystem Software	20
RJ-45 LAN Connector LEDs	20
Hi-Speed USB 2.0 Support	20
Enhanced IDE Interface	20
Serial ATA	21
Expandability	21
BIOS	21
Serial ATA and IDE Auto Configuration	21
PCI and PCI Express Auto Configuration	21
Security Passwords	22
Chassis Intrusion	22
Power Management Features	22
ACPI	22
Power Connectors	22
Fan Connectors	23
Fan Speed Control (Intel® Precision Cooling Technology)	23
Suspend to RAM (Instantly Available PC Technology)	23
Resume on Ring	24
Wake from USB	24
Wake from PS/2 Keyboard/Mouse	25
PME# Wakeup Support	25
Speaker	25
Battery	25
Real-Time Clock	25

2 Installing and Replacing Desktop Board Components

Before You Begin	27
Installation Precautions	28
Installation Instructions	28
Ensure Electromagnetic Compatibility (EMC) Compliance	28
Chassis and Component Certifications	29
Prevent Power Supply Overload	29
Place Battery Marking	29
Use Only for Intended Applications	30

Installing the I/O Shield	30
Installing and Removing the Desktop Board	31
Installing and Removing a Processor	32
Installing a Processor	32
Installing the Processor Fan Heat Sink	34
Connecting the Processor Fan Heat Sink Cable	35
Removing the Processor	35
Installing and Removing Memory	36
Installing DIMMs	38
Removing DIMMs	40
Installing and Removing a PCI Express x16 Card	40
Installing a PCI Express Card	40
Removing the PCI Express Card	41
Connecting the IDE Cable	42
Connecting the Serial ATA Cable	43
Connecting Internal Headers	44
Installing a Front Panel Audio Solution	45
Connecting USB 2.0 Headers	46
Connecting the Front Panel Header	46
Setting Up the Flexible 6-Channel Audio with Jack Re-tasking	47
Connecting Fan and Power Cables	48
Connecting Fan Cables	48
Connecting Power Cables	49
Connecting 2x10 Power Supply Cables	49
Connecting 2x12 Power Supply Cables	50
Add-In Card and Peripheral Interface Connectors	51
Setting the BIOS Configuration Jumper Block	52
Clearing Passwords	53
Back Panel Connectors	54
Replacing the Battery	55
3 BIOS	
Updating the BIOS with the Intel® Express BIOS Update Utility	59
Updating the BIOS with the Iflash Memory Update Utility	59
Obtaining the BIOS Update File	59
Updating the BIOS	60
Recovering the BIOS	60
4 Desktop Board Resources	
Memory Map	63
DMA Channels	63
Interrupts	64
A Error Messages and Indicators	
BIOS Beep Codes	65
BIOS Error Messages	66

B Regulatory Compliance

Safety Regulations	69
European Union Declaration of Conformity Statement	69
Product Ecology Statements	70
EMC Regulations	71
Product Certification Markings (Board Level)	72

Figures

1. Desktop Boards D915PGN and D915PCY Components.....	12
2. Intel Desktop Boards D915PSY and D915PCM Components.....	14
3. Location of Standby Power Indicator.....	24
4. Installing the I/O Shield	30
5. Desktop Board D915PGN and D915PCY Mounting Screw Hole Locations.....	31
6. Lift Socket Lever	32
7. Lift the Load Plate and Don't Touch the Socket Contacts	32
8. Remove the Protective Cover	33
9. Remove the Processor from the Protective Cover	33
10. Install Processor	34
11. Close the Load Plate	34
12. Connecting the Processor Fan Heat Sink Cable to the Processor Fan Connector	35
13. Dual Configuration Example 1	36
14. Dual Configuration Example 2	37
15. Dual Configuration Example 3	37
16. Matching the Correct DIMM	38
17. Installing a DIMM.....	39
18. Removing the PCI Express x16 Card.....	41
19. Connecting the IDE Cable	42
20. Connecting the Serial ATA Cable	43
21. Internal Headers	44
22. Back Panel Audio Connectors for Flexible 6-Channel Audio System	47
23. Location of Fan Headers.....	48
24. Connecting 2x10 Power Supply Cables	49
25. Connecting 2x12 Power Supply Cables	50
26. Location of the PCI Bus Add-in Card and Peripheral Interface Connectors for Desktop Boards D915PGN and D915PCY.....	51
27. Location of the BIOS Configuration Jumper Block	52
28. Back Panel Connectors	54
29. Removing the Battery	58

Tables

1. Feature Summary	9
2. Manufacturing Option.....	11
3. Desktop Boards D915PGN and D915PCY Components.....	13
4. Desktop Boards D915PSY and D915PCM Components.....	15
5. Desktop Board D915PGN/D915PSY Memory Configurations	17
6. Desktop Board D915PCY/D915PCM Memory Configurations.....	17
7. RJ-45 10/100 Ethernet LAN Connector LEDs	20
8. Front Panel Audio Header Signal Names.....	45

9. USB 2.0 Header Signal Names.....	46
10. Front Panel Header Signal Names.....	46
11. Jumper Settings for the BIOS Setup Program Modes	52
12. System Memory Map.....	63
13. DMA Channels.....	63
14. Interrupts	64
15. Beep Codes.....	65
16. BIOS Error Messages.....	66
17. Safety Regulations.....	69
18. EMC Regulations.....	71
19. Product Certification Markings	72

1 Desktop Board Features

This chapter briefly describes the main features of Intel® Desktop Board D915PGN/D915PSY/D915PCY/D915PCM. Table 1 summarizes the major features of the desktop board.

Table 1. Feature Summary

Processor	Support for an Intel® Pentium® 4 processor in the LGA775 package
Main Memory	<p>Desktop boards D915PGN and D915PSY:</p> <ul style="list-style-type: none"> • Four 184-pin, 2.5 V SDRAM Dual Inline Memory Module (DIMM) sockets • 400/333 MHz single or dual channel DDR SDRAM interface • Designed to support up to 4 GB of system memory <p>Desktop boards D915PCY and D915PCM:</p> <ul style="list-style-type: none"> • Four 240-pin, 1.8 V SDRAM Dual Inline Memory Module (DIMM) sockets • 533/400 MHz single or dual channel DDR2 SDRAM interface • Designed to support up to 4 GB of system memory <p>NOTE: System resources (such as PCI and PCI Express*) require physical memory address locations that reduce available memory addresses above 3 GB. This may result in less than 4 GB of memory being available to the operating system and applications. For the latest list of tested memory, refer to the Intel World Wide Web site at: http://support.intel.com/support/motherboards/desktop/</p>
Chipset	<p>Intel® 915P Express Chipset consisting of:</p> <ul style="list-style-type: none"> • Intel® 82915P Memory Controller Hub (MCH) with Direct Media Interface • Intel® 82801FB I/O Controller Hub (ICH6) • Firmware Hub (FWH)
Audio	<ul style="list-style-type: none"> • Intel 915P Express Chipset • Intel® High Definition Audio • Realtek codec
Expansion Capabilities	<p>Desktop boards D915PGN and D915PCY:</p> <ul style="list-style-type: none"> • Four PCI bus add-in card connectors (SMBus routed to PCI bus 2) • One x16 PCI Express connector and two x1 PCI Express connectors <p>Desktop boards D915PSY and D915PCM:</p> <ul style="list-style-type: none"> • Two PCI bus add-in card connectors (SMBus routed to PCI bus 2) • One x16 PCI Express connector and one x1 PCI Express connector

continued

Table 1. Feature Summary (continued)

<p><u>Peripheral Interfaces</u></p>	<ul style="list-style-type: none"> • Up to eight USB 2.0 ports <ul style="list-style-type: none"> — Four ports routed to the back panel — Four ports routed to two USB headers • Four Serial ATA (SATA) channels, via the ICH6, one device per channel • One IDE interface with ATA-66/100 supporting up to two devices • One diskette drive interface • One parallel port • One serial port • PS/2* keyboard and mouse ports
<p><u>BIOS</u></p>	<ul style="list-style-type: none"> • Intel/AMI BIOS • 4 Mbit symmetrical flash memory • Support for SMBIOS • Intel® Rapid BIOS Boot • Intel® Express BIOS Update
<p><u>Power Management</u></p>	<ul style="list-style-type: none"> • Support for Advanced Configuration and Power Interface (ACPI) • Suspend to RAM (STR) • Wake on USB, PCI, PCI Express, PS/2, LAN, and front panel
<p><u>Hardware Management</u></p>	<p>Hardware monitor with:</p> <ul style="list-style-type: none"> • Four fan sensing inputs used to monitor fan activity • Remote diode temperature sensing • Intel® Precision Cooling Technology fan speed control that automatically adjusts processor fan speeds based on processor temperature and chassis fan speeds based on system temperature • Voltage sensing to detect out of range values

Related Links

For more information about Intel Desktop Board D915PGN/D915PSY/D915PCY/D915PCM, including the Technical Product Specification (TPS), BIOS updates, and device drivers, go to:

<http://support.intel.com/support/motherboards/desktop/>

Manufacturing Options

Table 2 shows the manufacturing option for Desktop Board D915PGN/D915PSY/D915PCY/D915PCM.

Table 2. Manufacturing Option

Option	Description
LAN	Intel® 82562EZ 10/100 Mbit/sec Platform LAN Connect (PLC) device with RJ-45 connector

Supported Operating Systems

The desktop board supports the following operating systems:

- Microsoft Windows* 2000
- Microsoft Windows XP

Desktop Board Components

Figure 1 shows the approximate location of the major components on Desktop Board D915PGN and D915PCY.

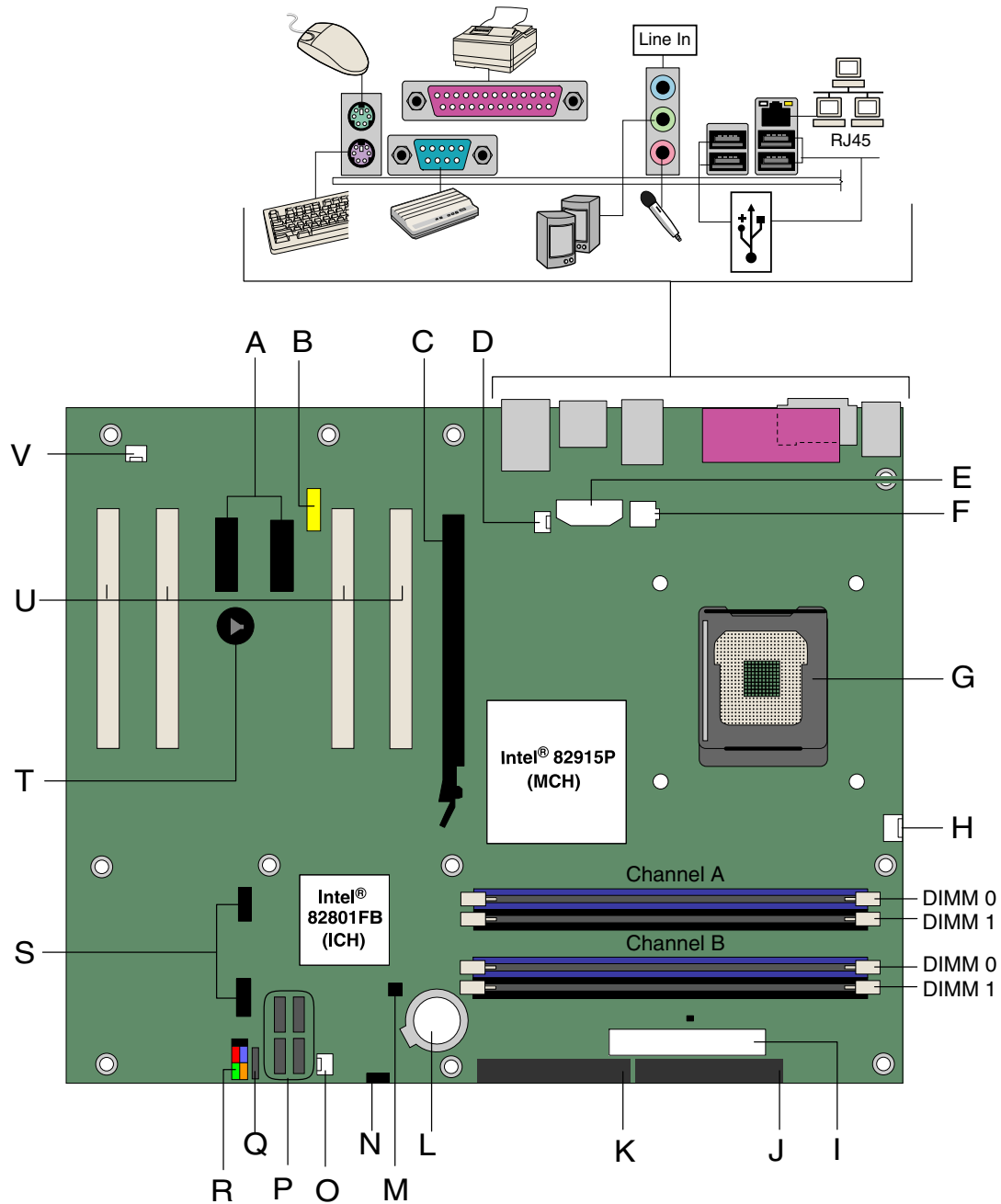

OM16846

Figure 1. Desktop Boards D915PGN and D915PCY Components

Table 3. Desktop Boards D915PGN and D915PCY Components

Label	Description
A	PCI Express x1 connectors
B	Front panel audio header
C	PCI Express x16 connector
D	Rear chassis fan header 1 (fan speed control)
E	Alternate power connector (1x4)
F	12 V processor core voltage connector (2x2)
G	Processor socket
H	Processor fan header (4-pin, controlled)
I	Main power connector (2x12)
J	Diskette drive connector
K	Primary IDE connector
L	Battery
M	Chassis intrusion header
N	BIOS configuration jumper
O	Front chassis fan header (fan speed control)
P	Serial ATA connectors
Q	Power LED header
R	Front panel header
S	USB 2.0 headers
T	Speaker
U	PCI bus add-in card connectors
V	Rear chassis fan header 2 (always on)

Figure 2 shows the approximate location of the major components on Desktop Boards D915PSY and D915PCM.

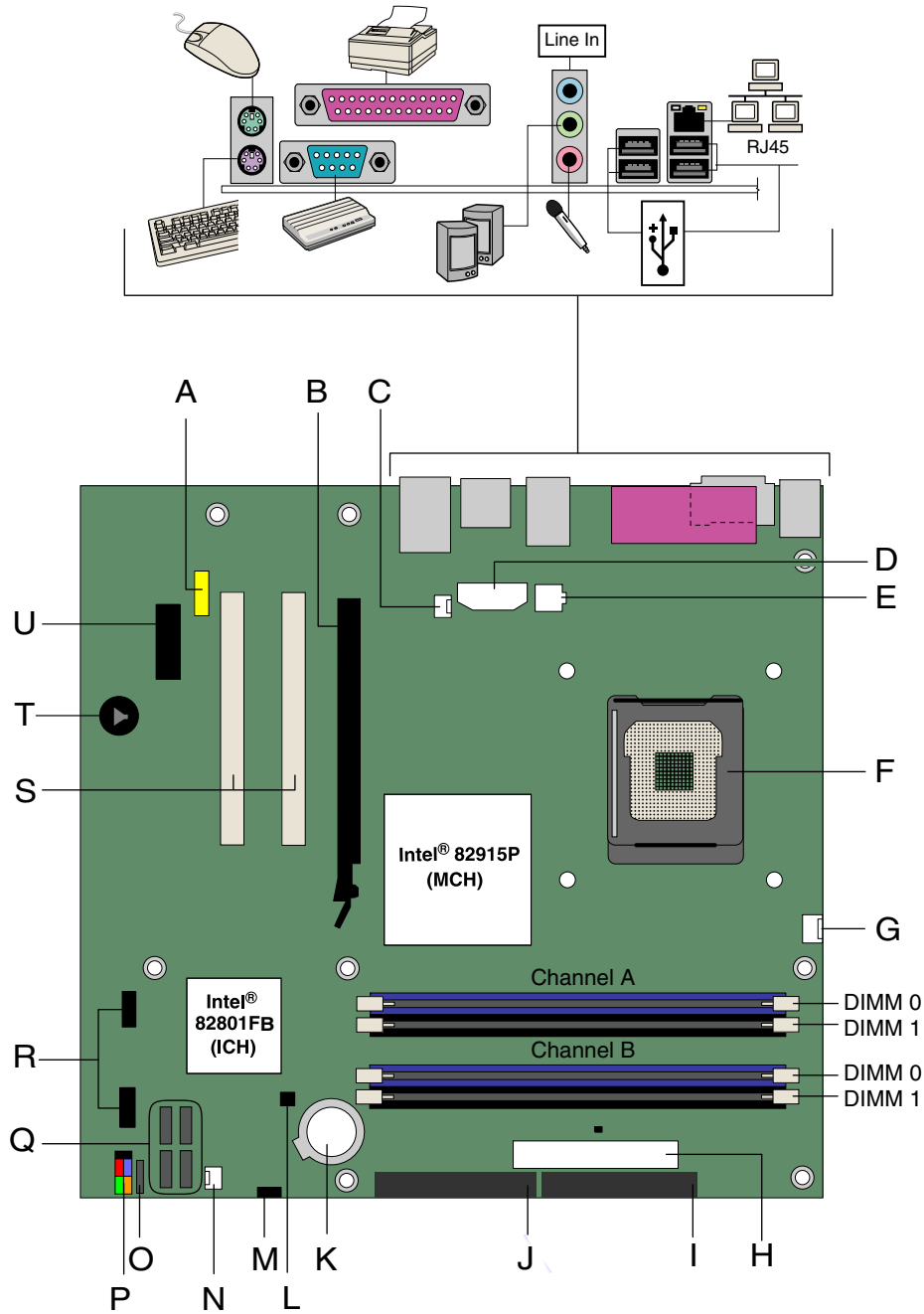

OM16848

Figure 2. Intel Desktop Boards D915PSY and D915PCM Components

Table 4. Desktop Boards D915PSY and D915PCM Components

Label	Description
A	Front panel audio header
B	PCI Express x16 connector
C	Rear chassis fan header (fan speed control)
D	Alternate power connector (1x4)
E	12 V processor core voltage connector (2x2)
F	Processor socket
G	Processor fan header (4-pin, controlled)
H	Main power connector (2x12)
I	Diskette drive connector
J	Primary IDE connector
K	Battery
L	Chassis intrusion header
M	BIOS configuration jumper
N	Front chassis fan header (fan speed control)
O	Power LED header
P	Front panel header
Q	Serial ATA connectors
R	USB 2.0 headers
S	PCI bus add-in card connectors
T	Speaker
U	PCI Express x1 connector

Related Links

Go to the following links for more information about:

- Intel Desktop Board D915PGN/D915PSY/D915PCY/D915PCM <http://www.intel.com/design/motherbd>
<http://support.intel.com/support/motherboards/desktop>
- Supported processors <http://support.intel.com/support/motherboards/desktop>
- Audio software and utilities <http://www.intel.com/design/motherbd>
- LAN software and drivers <http://www.intel.com/design/motherbd>

Processor



CAUTION

Failure to use an ATX12V power supply, or not connecting the 12 V (2x2) processor core voltage power supply connector to Desktop Board D915PGN/D915PSY/D915PCY/D915PCM may result in damage to the desktop board and/or power supply.

Desktop Boards D915PGN, D915PSY, D915PCY, and D915PCM support a single Intel Pentium 4 processor in the LGA775 package. Processors are not included with the desktop board and must be purchased separately.

The processor connects to the Intel desktop board through the LGA775 socket.

The supported processors list for Desktop Boards D915PGN, D915PSY, D915PCY, and D915PCM is located on the web at:

<http://support.intel.com/support/motherboards/desktop/>

Related Links

Go to the following links or pages for more information about:

- Supported Intel® processors for Desktop Board D915PGN/D915PSY/D915PCY/D915PCM
<http://support.intel.com/support/motherboards/desktop/>
- Instructions on installing or upgrading the processor, page 32 in Chapter 2
- The location of the two power connectors, page 48 in Chapter 2

Main Memory



NOTE

To be fully compliant with all applicable Intel® SDRAM memory specifications, the board should be populated with DIMMs that support the Serial Presence Detect (SPD) data structure. If your memory modules do not support SPD, you will see a notification to this effect on the screen at power up. The BIOS will attempt to configure the memory controller for normal operation.

Desktop boards D915PGN and D915PSY support dual or single channel memory configurations defined in Table 5.

Table 5. Desktop Board D915PGN/D915PSY Memory Configurations

Memory Speed	Processor	FSB Frequency (MHz)	Memory Speed Outcome (MHz)
DDR 400	Pentium 4 processor	800	400
		533	400
DDR 333	Pentium 4 processor	800	333
		533	333

Four 184-pin Double Data Rate (DDR) SDRAM Dual Inline Memory Module (DIMMs) connectors with gold-plated contacts.

- Support for:
 - Unbuffered, non-registered single or double-sided DIMMs
 - Serial Presence Detect (SPD) memory only
 - Non-ECC RAM
 - 2.5 V memory
 - Memory configuration listed below:
 - Up to 4.0 GB utilizing 512 Mb or 1 GB technology
 - Up to 2.0 GB utilizing 256 Mb technology

Desktop boards D915PCY and D915PCM support dual or single channel memory configurations defined in Table 6.

Table 6. Desktop Board D915PCY/D915PCM Memory Configurations

Memory Speed	Processor	FSB Frequency (MHz)	Memory Speed Outcome (MHz)
DDR2 533	Pentium 4 processor	800	533
		533	533
DDR2 400	Pentium 4 processor	800	400
		533	400

Four 240-pin Double Data Rate 2 (DDR2) SDRAM Dual Inline Memory Module (DIMMs) connectors with gold-plated contacts.

- Support for:
 - Unbuffered, non-registered single or double-sided DIMMs
 - Serial Presence Detect (SPD) memory only
 - Non-ECC RAM
 - 1.8 V memory
 - Memory configuration listed below:
 - Up to 4.0 GB utilizing 512 Mb or 1 GB technology
 - Up to 2.0 GB utilizing 256 Mb technology



NOTE

System resources (such as PCI and PCI Express) require physical memory address locations that reduce available memory addresses above 3 GB. This may result in less than 4 GB of memory being available to the operating system and applications.

Related Links

Go to the following links or pages for more information about:

- The latest list of tested memory, <http://support.intel.com/support/motherboards/desktop/>
- SDRAM specifications, <http://www.intel.com/technology/memory/pcsdram/spec/>
- Installing memory, page 36 in Chapter 2

Intel® 915P Express Chipset

The Intel 915P Express Chipset consists of the following devices:

- Intel 82915P Memory Controller Hub (MCH)
- Intel 82801FB I/O Controller Hub (ICH6) with Direct Media Interface
- Firmware Hub (FWH)

Related Link

Go to the following link for more information about the Intel 915P chipset:

<http://developer.intel.com/design/nav/pcserver.htm>

Audio Subsystem

Desktop Board D915PGN/D915PSY/D915PCY/D915PCM includes a flexible 6-channel audio subsystem based on a Realtek Semiconductor Corporation codec:

The audio subsystem features:

- Impedance sensing capability for jack re-tasking
- S/N (signal-to-noise) ratio: > 90 dB
- Power management support for ACPI 2.0 (driver dependent)
- Intel 82801FB I/O Controller Hub (ICH6)
- Realtek ALC860 audio codec

- Microphone input that supports:
 - Microphone array
 - Acoustic Echo (AEC)
 - Beam Forming (BF)
 - Noise Suppression (NX) technology

The subsystem includes the following connectors:

- Front panel audio connector, including pins for:
 - Line out
 - Line in
- Back panel audio connectors that are configurable through the drivers of the audio devices:
 - Line in or Rear left/right out
 - Line out or Front left/right out
 - Mic in or Center LFE out

Related Links

Go to the following link or pages for more information about:

- Audio drivers and utilities <http://support.intel.com/support/motherboards/desktop/>
- Installing the front panel audio solution, page 45 in Chapter 2
- The location of audio connectors, page Figure 22 on page 47

Input/Output (I/O) Controller

The super I/O controller features the following:

- Low pin count (LPC) interface
- One serial port
- One parallel port with Extended Capabilities Port (ECP) and Enhanced Parallel Port (EPP) support
- Serial IRQ interface compatible with serialized IRQ support for PCI systems
- PS/2-style mouse and keyboard interfaces
- Interface for one 1.2 MB, 1.44 MB, or 2.88 MB diskette drive
- Intelligent power management, including a programmable wake up event interface
- PCI power management support

LAN Subsystem (Optional)

The optional LAN, with the Intel 82801FB (ICH6), provides the following functions:

- Basic 10/100 Ethernet LAN (Intel 82562EZ)
- Support for RJ-45 connector with status indicator LEDs
- Programmable transit threshold
- Configurable EEPROM that contains the MAC address

LAN Subsystem Software

For LAN software and drivers, refer to the D915PGN/D915PSY/D915PCY/D915PCM link on Intel's World Wide Web site at:

<http://support.intel.com/support/motherboards/desktop>

RJ-45 LAN Connector LEDs

Two LEDs are built into the RJ-45 LAN connector. Table 7 describes the LED states when the board is powered up and the 10/100 Ethernet LAN subsystem is operating.

Table 7. RJ-45 10/100 Ethernet LAN Connector LEDs

LED Color	LED State	Indicates
Green	Off	10 Mbit/sec data rate is selected.
	On	100 Mbit/sec data rate is selected.
Yellow	Off	LAN link is not established.
	On (steady state)	LAN link is established.
	On (brighter and pulsing)	The computer is communicating with another computer on the LAN.

Hi-Speed USB 2.0 Support



NOTE

Computer systems that have an unshielded cable attached to a USB port might not meet FCC Class B requirements, even if no device or a low-speed USB device is attached to the cable. Use a shielded cable that meets the requirements for a full-speed USB device.

The desktop board supports up to eight USB 2.0 ports via ICH6; four ports routed to the back panel and four routed to two internal USB 2.0 headers. USB 2.0 ports are backward compatible with USB 1.1 devices. USB 1.1 devices will function normally at USB 1.1 speeds.

USB 2.0 support requires both an operating system and drivers that fully support USB 2.0 transfer rates. Disabling Hi-Speed USB in the BIOS reverts all USB 2.0 ports to USB 1.1 operation. This may be required to accommodate operating systems that do not support USB 2.0.

Enhanced IDE Interface

The ICH6's IDE interface handles the exchange of information between the processor and peripheral devices like hard disks, CD-ROM drives, and Iomega Zip* drives inside the computer. The interface supports:

- Up to two IDE devices (such as hard drives)
- ATAPI-style devices (such as CD-ROM drives)
- Older PIO Mode devices
- Ultra DMA-33 and ATA-66/100 protocols
- Laser Servo (LS-120) drives

Serial ATA

The desktop board supports four Serial ATA channels via the ICH6, connecting one device per channel.

Expandability

The desktop boards support the following:

- Desktop boards D915PGN and D915PCY:
 - One PCI Express x16 add-in card
 - Two PCI Express x1 add-in cards
 - Four PCI add-in cards
- Desktop boards D915PSY and D915PCM:
 - One PCI Express x16 add-in card
 - One PCI Express x1 add-in card
 - Two PCI add-in cards

Related Links

For information about installing a PCI Express card, see page 40 in Chapter 2.

BIOS

The BIOS provides the Power-On Self-Test (POST), the BIOS Setup program, the PCI/PCI Express and IDE auto-configuration utilities, and the video BIOS. The BIOS is stored in the Firmware Hub.

The BIOS can be updated by following the instructions on page 59 in Chapter 3.

Serial ATA and IDE Auto Configuration

If you install a Serial ATA or IDE device (such as a hard drive) in your computer, the auto-configuration utility in the BIOS automatically detects and configures the device for your computer. You do not need to run the BIOS Setup program after installing a Serial ATA or IDE device. You can override the auto-configuration options by specifying manual configuration in the BIOS Setup program.

PCI and PCI Express Auto Configuration

If you install a PCI/PCI Express add-in card in your computer, the PCI/PCI Express auto-configuration utility in the BIOS automatically detects and configures the resources (IRQs, DMA channels, and I/O space) for that add-in card. You do not need to run the BIOS Setup program after you install a PCI/PCI Express add-in card.

Security Passwords

The BIOS includes security features that restrict whether the BIOS Setup program can be accessed and who can boot the computer. A supervisor password and a user password can be set for the BIOS Setup and for booting the computer, with the following restrictions:

- The supervisor password gives unrestricted access to view and change all Setup options. If only the supervisor password is set, pressing <Enter> at the password prompt of Setup gives the user restricted access to Setup.
- If both the supervisor and user passwords are set, you must enter either the supervisor password or the user password to access Setup. Setup options are then available for viewing and changing depending on whether the supervisor or user password was entered.
- Setting a user password restricts who can boot the computer. The password prompt is displayed before the computer is booted. If only the supervisor password is set, the computer boots without asking for a password. If both passwords are set, you can enter either password to boot the computer.

Chassis Intrusion

The board supports a chassis security feature that detects if the chassis cover has been removed. The security feature uses a mechanical switch on the chassis that can be connected to the chassis intrusion header on the desktop board. See Figure 23 on page 48 for the location of the chassis intrusion header.

Power Management Features

Power management is implemented at several levels, including:

- Advanced Configuration and Power Interface (ACPI)
- Hardware support:
 - Power connectors
 - Fan connectors
 - Suspend to RAM (Instantly Available PC technology)
 - Resume on Ring
 - Wake from USB
 - Wake from PS/2 keyboard/mouse
 - PME# wakeup support

ACPI

ACPI gives the operating system direct control over the power management and Plug and Play functions of a computer. The use of ACPI with the desktop board requires an operating system that provides full ACPI support.

Power Connectors

The desktop board has three power connectors. See Figure 23 on page 48 for the location of the power connectors.

Fan Connectors

The desktop boards have one 4-pin processor fan header.

Desktop boards D915PGN and D915PCY have three chassis fan headers. Desktop boards D915PSY and D915PCM have two chassis fan headers. See Figure 23 on page 48 for the location of the fan headers.

Fan Speed Control (Intel® Precision Cooling Technology)

Intel Precision Cooling Technology automatically adjusts the processor fan speed based on the processor temperature and adjusts the chassis fan speeds depending on the system temperature. System fan noise may be reduced by operating controlled chassis and processor fans at the minimum necessary speeds.



NOTE

Not all chassis fan headers on desktop boards D915PGN and D915PCY are controlled. Refer to Table 3 on page 13 to identify controlled chassis fan headers.

The processor and chassis fan speed control features can be disabled independently through the desktop board BIOS. Disabling the processor fan speed control will result in the fan operating at full speed if it is not a self controlled fan. It is recommended that processor fan speed control remain enabled (default BIOS setting) when using the processor fan heat-sink included with Intel boxed processors. Disabling the chassis fan speed control results in chassis fans always operating at full speed. The chassis fan speed control feature should be disabled if a self-controlled chassis fan is attached to any controlled chassis fan header.

The overall system noise reduction will vary based on system configuration and environment.

Suspend to RAM (Instantly Available PC Technology)



CAUTION

For Instantly Available PC technology, the 5 V standby line for the power supply must be capable of delivering adequate +5 V standby current. Failure to provide adequate standby current when using this feature can damage the power supply and/or effect ACPI S3 sleep state functionality.

Instantly Available PC technology enables the board to enter the ACPI S3 (Suspend-to-RAM) sleep state. While in the S3 sleep state, the computer will appear to be off. When signaled by a wake-up device or event, the system quickly returns to its last known awake state.

The desktop board's standby power indicator, shown in Figure 3, is lit when there is standby power to the system. This includes the memory modules and PCI bus connectors, even when the computer appears to be off.

If the system has a dual-colored power LED on the front panel, the sleep state is indicated by the LED turning amber.

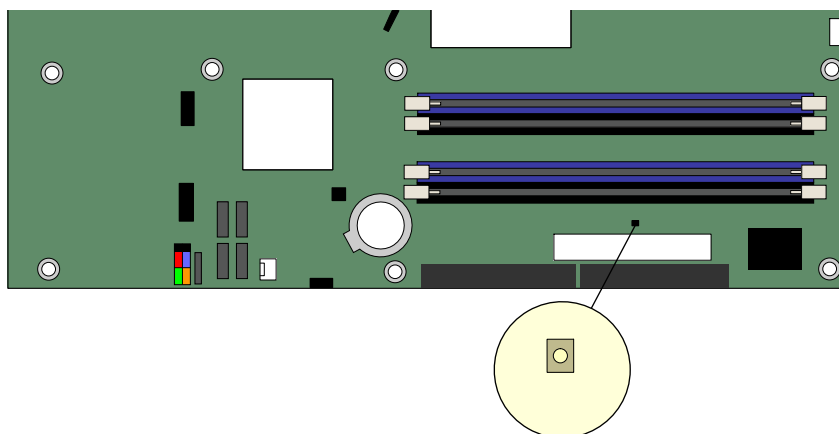

OM16879

Figure 3. Location of Standby Power Indicator



CAUTION

Power supplies used with this desktop board must be able to provide enough standby current to support the standard Instantly Available (ACPI S3 sleep state) configuration. If the standby current necessary to support multiple wake events from the PCI and/or USB buses exceeds power supply capacity, the desktop board may lose register settings stored in memory.

Related Links

For more information on standby current requirements for the desktop board, refer to the TPS by selecting the Technical Documentation link at:

<http://developer.intel.com/design/motherbd/>

Resume on Ring

The operation of Resume on Ring can be summarized as follows:

- Resumes operation from either ACPI S1 or ACPI S3 state
- Requires only one call to access the computer
- Detects incoming call similarly for external and internal modems
- Requires modem interrupt be unmasked for correct operation

Wake from USB

USB bus activity wakes the computer from an ACPI S1 or S3 state.



NOTE

Wake from USB requires the use of a USB peripheral that supports Wake from USB.

Wake from PS/2 Keyboard/Mouse

PS/2 keyboard/mouse activity wakes the computer from an ACPI S1 or S3 state.

PME# Wakeup Support

When the PME# signal on the PCI bus is asserted, the computer wakes from an ACPI S1, S3, or S5 state.

Speaker

A speaker is mounted on the desktop board. The speaker provides audible error code (beep code) information during the Power-On Self-Test (POST).

Battery

A battery on the desktop board keeps the values in CMOS RAM and the clock current when the computer is turned off. See Chapter 2 starting on page 27 for instructions on how to replace the battery.

Real-Time Clock

The desktop board has a time-of-day clock and 100-year calendar. The battery on the desktop board keeps the clock current when the computer is turned off.

2 Installing and Replacing Desktop Board Components

This chapter tells you how to:

- Install the I/O shield
- Install and remove the desktop board
- Install and remove a processor and memory
- Install and remove a x16 PCI Express card
- Connect the IDE and Serial ATA cables
- Connect the front panel header
- Install the front panel audio and USB solutions
- Connect fans and power cables
- Connect PCI bus add-in and PCI Express add-in cards
- Set the BIOS configuration jumper
- Clear passwords
- Replace the battery

Before You Begin



WARNINGS

The procedures in this chapter assume familiarity with the general terminology associated with personal computers and with the safety practices and regulatory compliance required for using and modifying electronic equipment.

Disconnect the computer from its power source and from any telecommunications links, networks, or modems before performing any of the procedures described in this chapter. Failure to disconnect power, telecommunications links, networks, or modems before you open the computer or perform any procedures can result in personal injury or equipment damage. Some circuitry on the board can continue to operate even though the front panel power button is off.

Follow these guidelines before you begin:

- Always follow the steps in each procedure in the correct order.
- Set up a log to record information about your computer, such as model, serial numbers, installed options, and configuration information.
- Electrostatic discharge (ESD) can damage components. Perform the procedures described in this chapter only at an ESD workstation using an antistatic wrist strap and a conductive foam pad. If such a station is not available, you can provide some ESD protection by wearing an antistatic wrist strap and attaching it to a metal part of the computer chassis.

Installation Precautions

When you install and test the Intel desktop board, observe all warnings and cautions in the installation instructions.

To avoid injury, be careful of:

- Sharp pins on connectors
- Sharp pins on printed circuit assemblies
- Rough edges and sharp corners on the chassis
- Hot components (like processors, voltage regulators, and heat sinks)
- Damage to wires that could cause a short circuit

Observe all warnings and cautions that instruct you to refer computer servicing to qualified technical personnel.

Installation Instructions



CAUTION

Follow these guidelines to meet safety and regulatory requirements when installing this board.

Read and adhere to all of these instructions and the instructions supplied with the chassis and associated modules. If the instructions for the chassis are inconsistent with these instructions or the instructions for associated modules, contact the supplier's technical support to find out how you can ensure that your computer meets safety and regulatory requirements. If you do not follow these instructions and the instructions provided by chassis and module suppliers, you increase safety risk and the possibility of noncompliance with regional laws and regulations.

Ensure Electromagnetic Compatibility (EMC) Compliance

Before computer integration, make sure that the power supply and other modules or peripherals, as applicable, have passed Class B EMC testing and are marked accordingly.

Pay close attention to the following when reading the installation instructions for the host chassis, power supply, and other modules:

- Product certifications or lack of certifications
- External I/O cable shielding and filtering
- Mounting, grounding, and bonding requirements
- Keying connectors when mating the wrong connectors could be hazardous

If the power supply and other modules or peripherals, as applicable, are not Class B EMC compliant before integration, then EMC testing is required on a representative sample of the newly completed computer.

Chassis and Component Certifications

Ensure that the chassis and certain components; such as the power supply, peripheral drives, wiring, and cables; are components certified for the country or market where used. Agency certification marks on the product are proof of certification. Typical product certifications include:

- **In Europe**

The CE marking signifies compliance with all applicable European requirements. If the chassis and other components are not properly CE marked, a supplier's Declaration of Conformity statement to the European EMC directive and Low Voltage directive (as applicable), should be obtained. Additionally, other directives, such as the Radio and Telecommunications Terminal Equipment (R&TTE) directive may also apply depending on product features.

- **In the United States**

A certification mark by a Nationally Recognized Testing Laboratory (NRTL) such as UL, CSA, or ETL signifies compliance with safety requirements. Wiring and cables must also be UL listed or recognized and suitable for the intended use. The FCC Class B logo for home or office use signifies compliance with electromagnetic interference (EMI) requirements.

- **In Canada**

A nationally recognized certification mark such as CSA or cUL signifies compliance with safety requirements. The Industry Canada statement at the front of this product guide demonstrates compliance with Canadian EMC regulations. Industry Canada recognizes and accepts FCC certification as denoting compliance with national electromagnetic interference (emissions) requirements.

Prevent Power Supply Overload

Do not overload the power supply output. To avoid overloading the power supply, make sure that the calculated total current loads of all the modules within the computer is less than the output current rating of each of the power supplies output circuits.

Place Battery Marking

There is insufficient space on this Desktop Board to provide instructions for replacing and disposing of the Lithium ion coin cell battery. For system safety certification, the following statement or equivalent statement is required to be permanently and legibly marked on the chassis near the battery.



CAUTION

Risk of explosion if the battery is replaced with an incorrect type. Batteries should be recycled where possible. Disposal of used batteries must be in accordance with local environmental regulations.

Related Links

For information about replacing the battery, go to page 54 in Chapter 2.

Use Only for Intended Applications

All Intel desktop boards are evaluated as Information Technology Equipment (I.T.E.) for use in personal computers for installation in homes, offices, schools, computer rooms, and similar locations. The suitability of this product for other applications or environments, such as medical, industrial, alarm systems, test equipment, etc. may require further evaluation.

Related Links

For information about regulatory compliance, go to Appendix B on page 69.

Installing the I/O Shield

The desktop board comes with an I/O shield. When installed in the chassis, the shield blocks radio frequency transmissions, protects internal components from dust and foreign objects, and promotes correct airflow within the chassis.

Install the I/O shield before installing the desktop board in the chassis. Place the shield inside the chassis as shown in Figure 4. Press the shield into place so that it fits tightly and securely. If the shield doesn't fit, obtain a properly-sized shield from the chassis supplier.

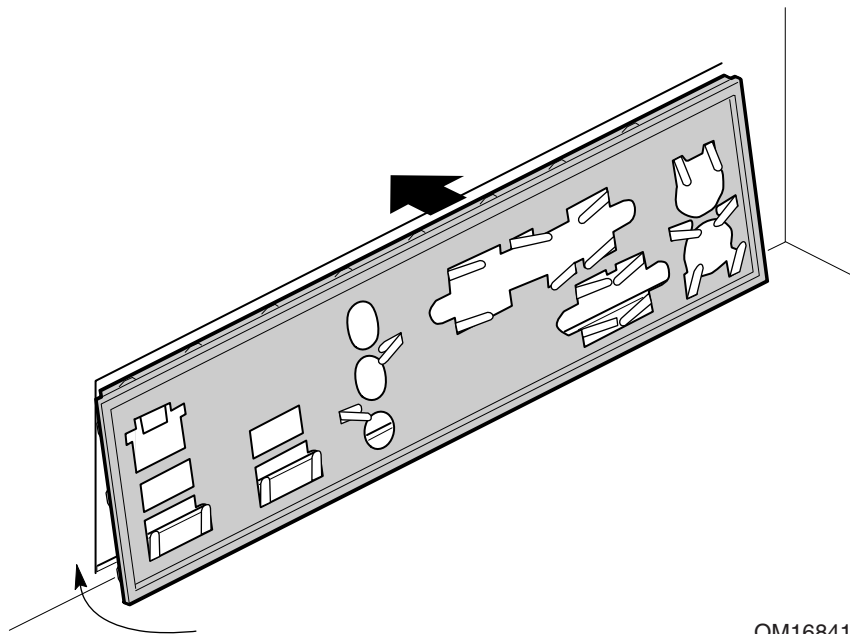

OM16841

Figure 4. Installing the I/O Shield

Installing and Removing the Desktop Board

⚠ WARNING

Only qualified technical personnel should do this procedure. Disconnect the computer from its power source before performing the procedures described here. Failure to disconnect the power before you open the computer can result in personal injury or equipment damage.



NOTE

Refer to Appendix B for regulatory requirements.

Refer to your chassis manual for instructions on installing and removing the desktop board.

Figure 5 shows the location of the 11 mounting screw holes for desktop boards D915PGN and D915PCY. Desktop boards D915PSY and D915PCM have eight mounting screw holes.

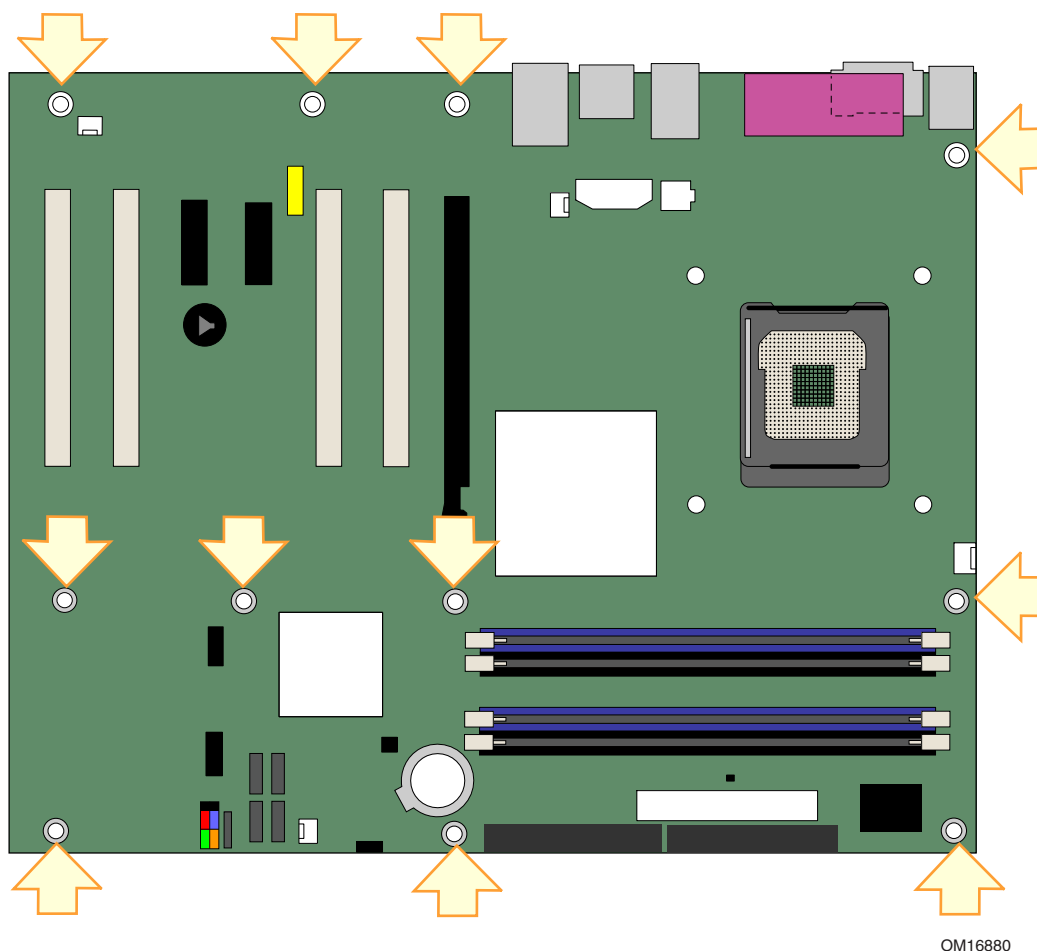

OM16880

Figure 5. Desktop Board D915PGN and D915PCY Mounting Screw Hole Locations

Installing and Removing a Processor

Instructions on how to install the processor to the desktop board are given below.

Installing a Processor



CAUTION

Before installing or removing the processor, make sure that AC power has been removed by unplugging the power cord from the computer; the standby power LED should not be lit (see Figure 3 on page 24). Failure to do so could damage the processor and the board.

To install a processor, follow these instructions:

1. Observe the precautions in "Before You Begin" on page 27.
2. Open the socket lever by pushing the lever down and away from the socket (see Figure 6, A and B).

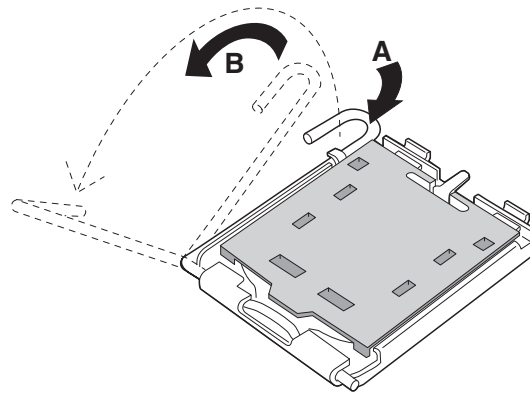

Figure 6. Lift Socket Lever

3. Lift the load plate. Do not touch the socket contacts (see Figure 7, C and D).

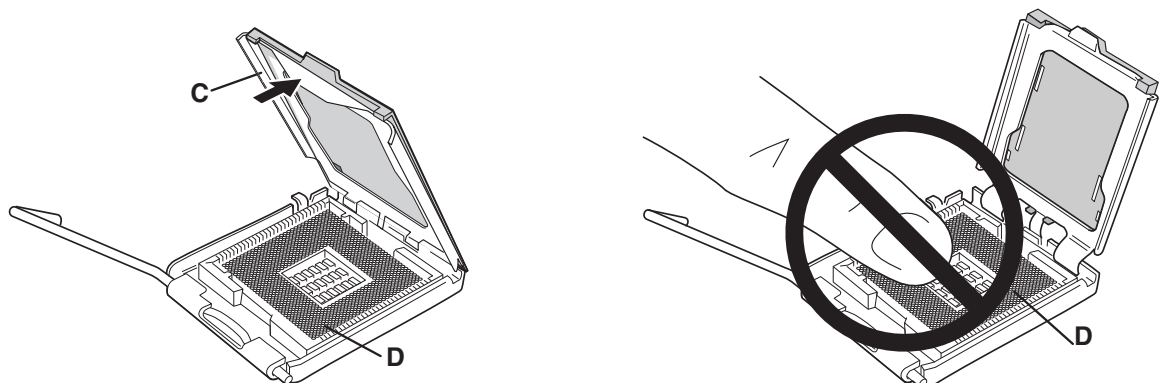

Figure 7. Lift the Load Plate and Don't Touch the Socket Contacts

4. Remove the protective cover from the load plate. Do not discard the protective cover. Always replace the socket cover if the processor is removed from the socket (see Figure 8, E).

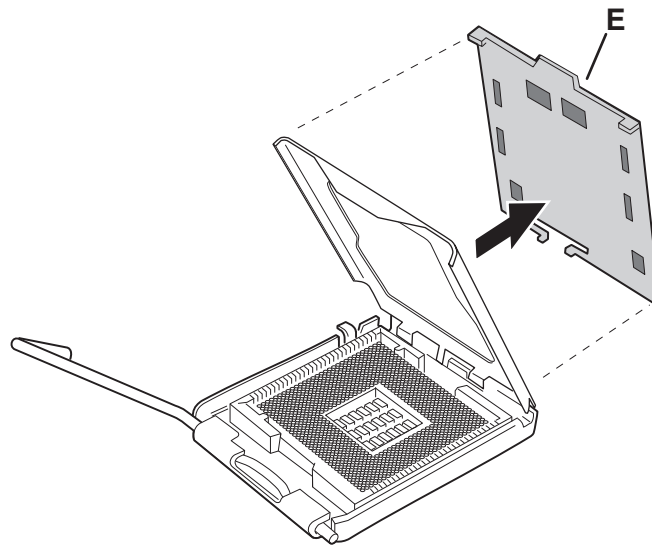

Figure 8. Remove the Protective Cover

5. Remove the processor from the protective cover. Hold the processor only at the edges, being careful not to touch the bottom of the processor. Do not discard the protective cover. Always replace the processor cover if the processor is removed from the socket (see Figure 9).

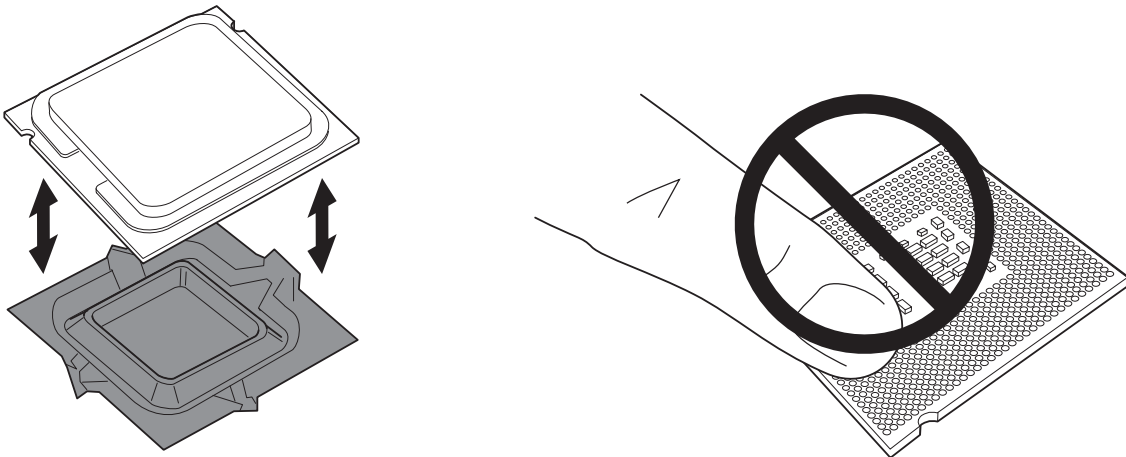

Figure 9. Remove the Processor from the Protective Cover

6. Hold the processor with your thumb and index fingers oriented as shown in Figure 10. Make sure fingers align to the socket cutouts (see Figure 10, F). Align notches (see Figure 10, G) with the socket see (Figure 10, H). Lower the processor straight down without tilting or sliding the processor in the socket.

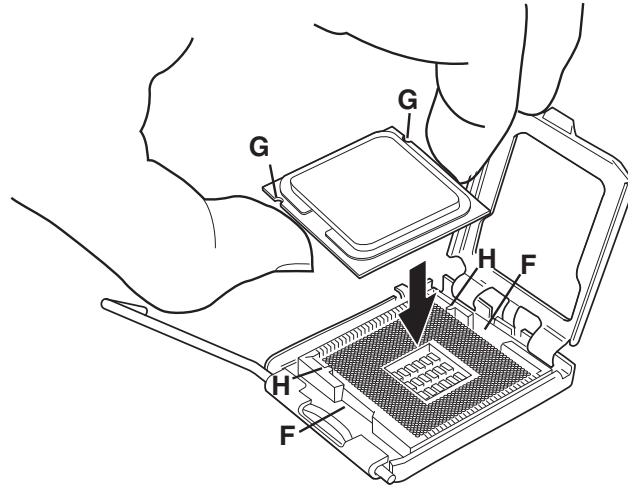

Figure 10. Install Processor

7. Pressing down on the load plate (Figure 11, I) close and engage the socket lever (Figure 11, J).

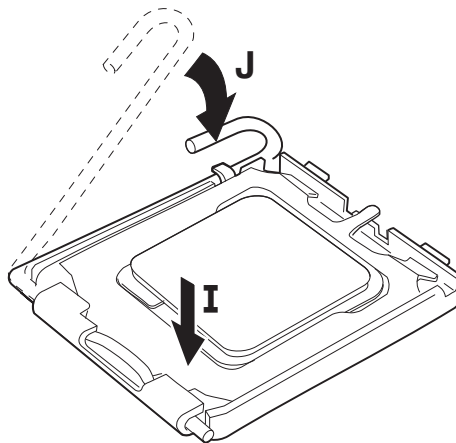

Figure 11. Close the Load Plate

Installing the Processor Fan Heat Sink

Desktop Board D915PGN/D915PSY/D915PCY/D915PCM has an integrated processor fan heat sink retention mechanism (RM). For instructions on how to attach the processor fan heat sink to the integrated processor fan heat sink RM, refer to the boxed processor manual or the Intel World Wide Web site at:

<http://support.intel.com/support/processors/pentium4/intnotes478.htm>

Connecting the Processor Fan Heat Sink Cable

Connect the processor fan heat sink cable to the 4-pin processor fan connector (see Figure 12). Refer to Figure 23 on page 48 for more information about 3-pin and 4-pin connections.

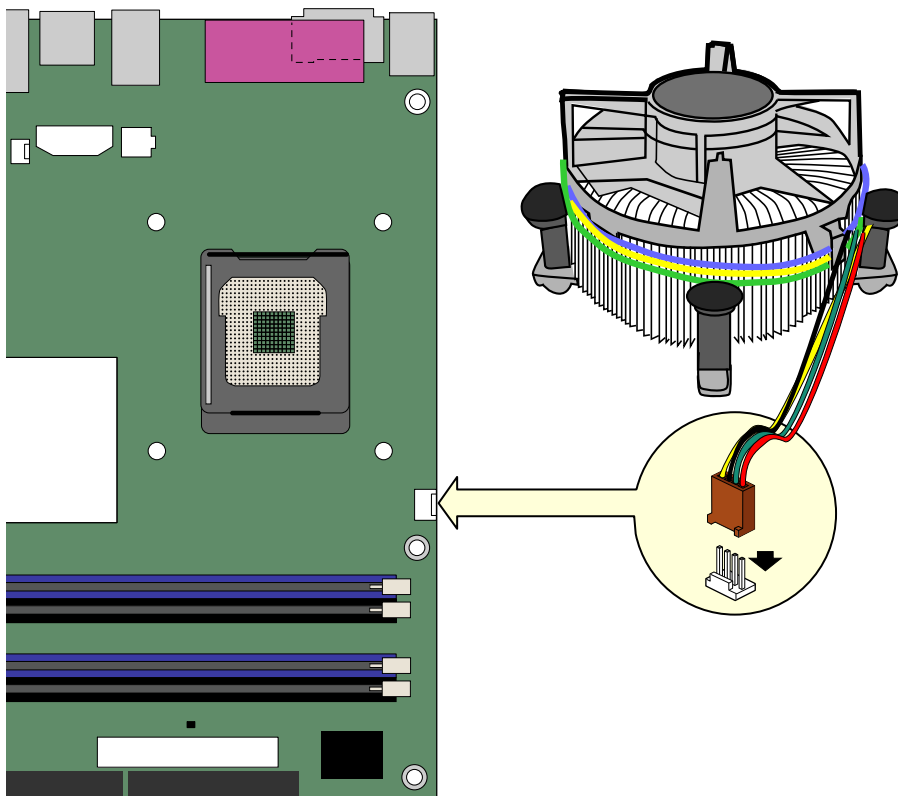

OM16881

Figure 12. Connecting the Processor Fan Heat Sink Cable to the Processor Fan Connector

Removing the Processor

For instruction on how to remove the processor fan heat sink and processor, refer to the processor installation manual or the Intel World Wide Web site at:

<http://support.intel.com/support/processors/pentium4/intnotes478.htm>

Installing and Removing Memory



NOTE

To be fully compliant with all applicable Intel® SDRAM memory specifications, the boards require DIMMs that support the Serial Presence Detect (SPD) data structure. You can access the PC Serial Presence Detect Specification at:

<http://www.intel.com/technology/memory/pcsdram/spec/>

Desktop boards D915PGN and D915PCY have four 184-pin DDR DIMM sockets arranged as DIMM 0 (blue) and DIMM 1 (black) in both Channel A and Channel B.

Desktop boards D915PSY and D915PCM have four 240-pin DDR2 DIMM sockets arranged as DIMM 0 (blue) and DIMM (black) 1 in both Channel A and Channel B.

Figure 17 shows the DIMM socket locations.

Guidelines for Dual Channel Memory Configuration

Before installing DIMMs, read and follow these guidelines for dual channel configuration.

Two or Four DIMMs

Install a matched pair of DIMMs equal in speed and size (see Figure 13) in DIMM 0 (blue) of both channels A and B.

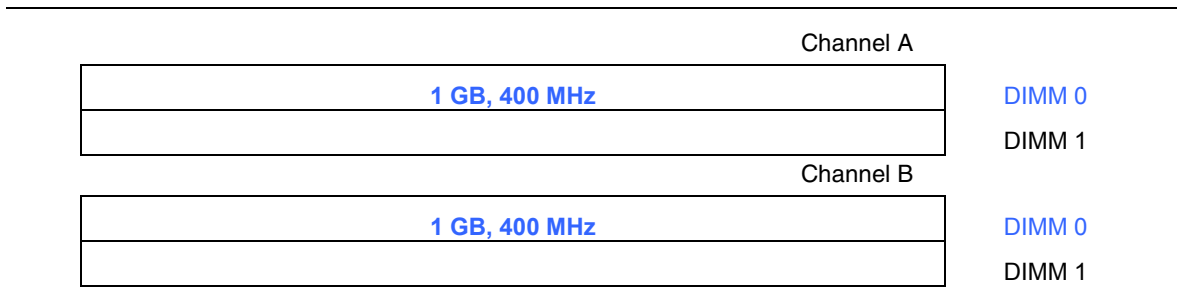

Figure 13. Dual Configuration Example 1

If additional memory is to be used, install another matched pair of DIMMs in DIMM 1 (black) in both channels A and B (see Figure 14).

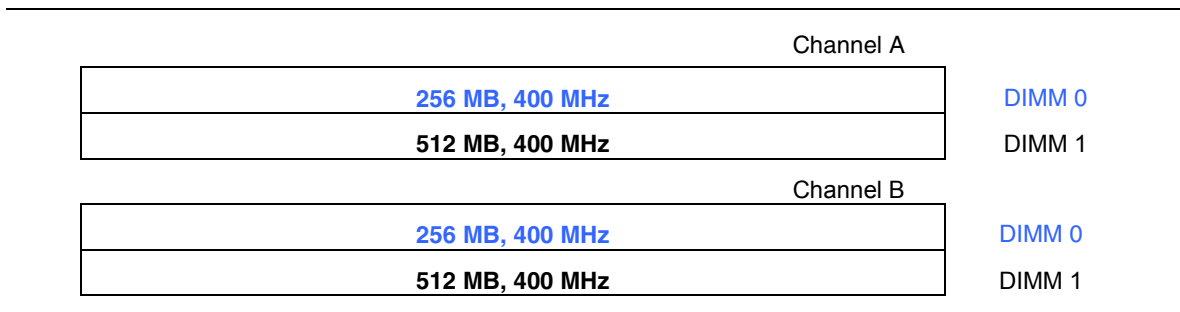

Figure 14. Dual Configuration Example 2

Three DIMMs

Install a matched pair of DIMMs equal in speed and size in DIMM 0 (blue) and DIMM 1 (black) of channel A. Install a DIMM equal in speed and total size of the DIMMs installed in channel A in either DIMM 0 or DIMM 1 of channel B (see Figure 15).

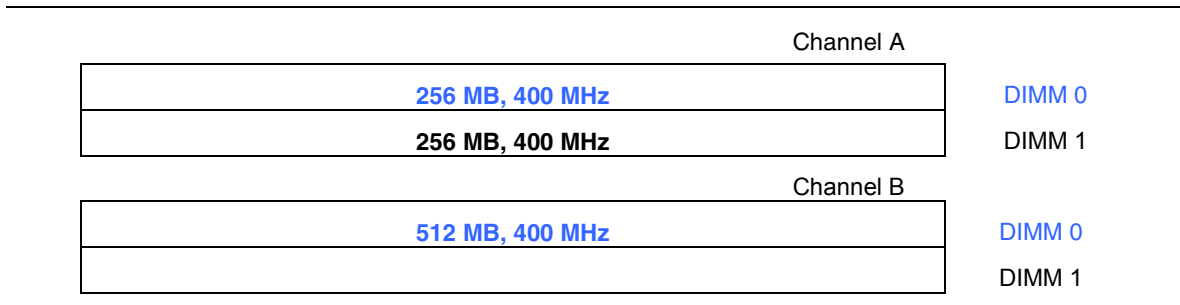

Figure 15. Dual Configuration Example 3



NOTE

All other memory configurations will result in single channel memory operation.

Installing DIMMs



CAUTION

Install memory in the DIMM sockets prior to installing a PCI Express video card to avoid interference with the memory retention mechanism.

To make sure you have the correct DIMM, place the DIMM on the illustration in Figure 16 to match the correct DIMM.

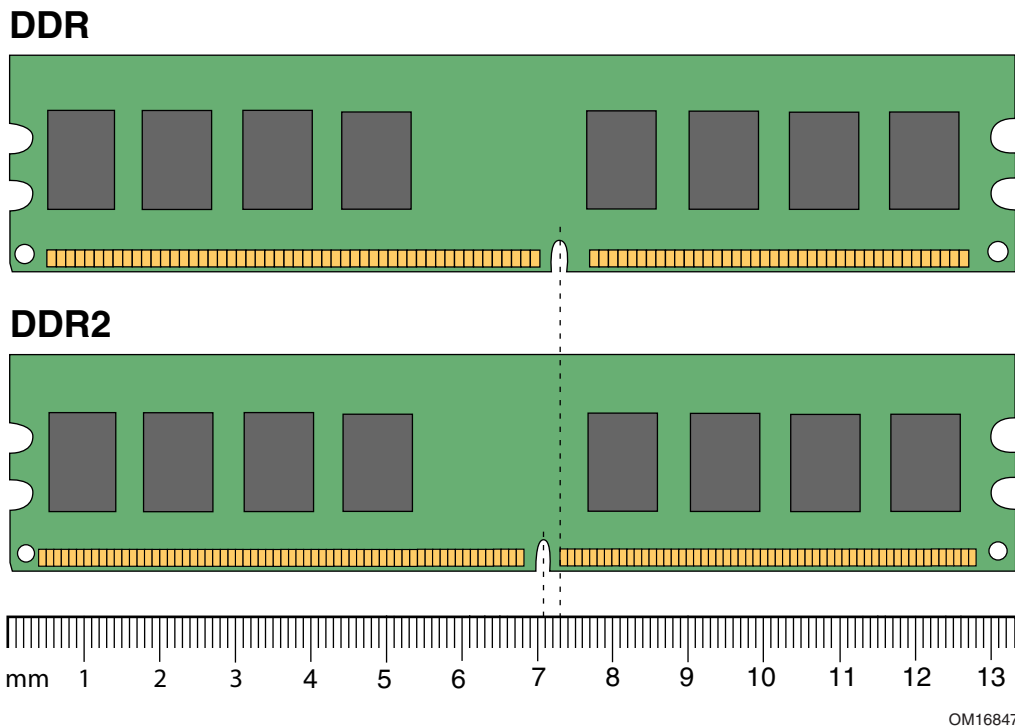
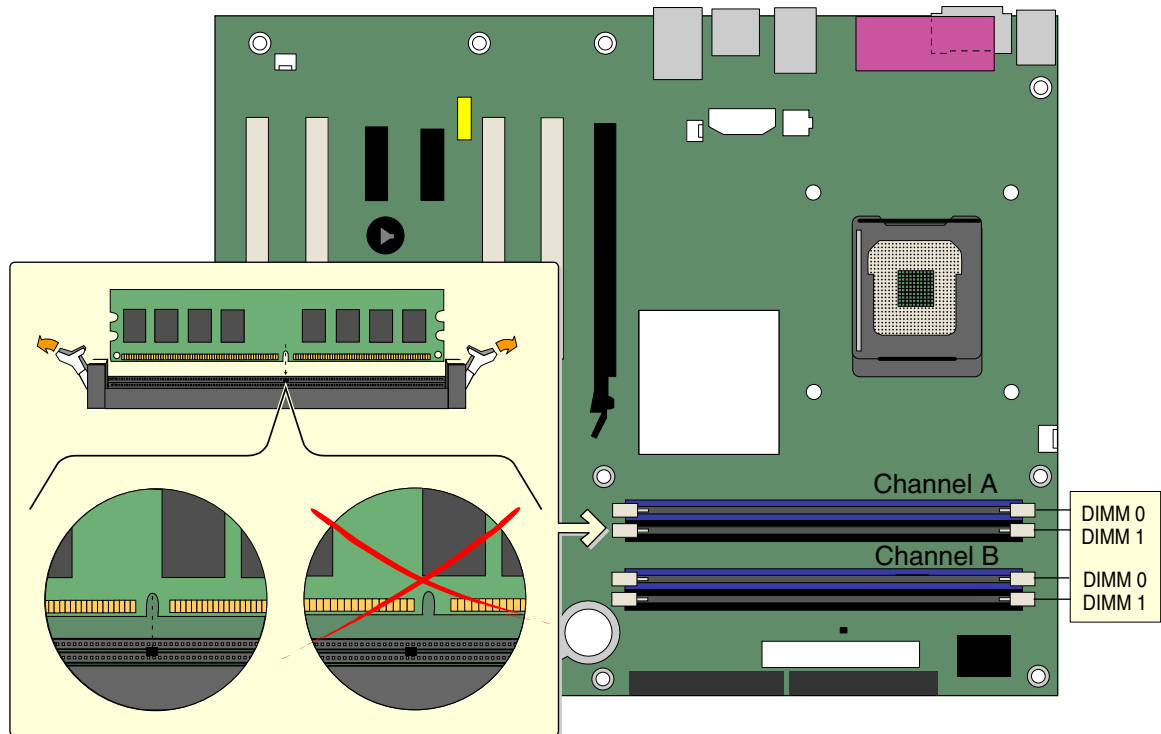

Figure 16. Matching the Correct DIMM

1. Observe the precautions in "Before You Begin" on page 27.
2. Turn off all peripheral devices connected to the computer. Turn off the computer and disconnect the AC power cord.
3. Remove the computer's cover and locate the DIMM sockets (see Figure 17).
4. Remove the PCI Express video card if it interferes with the DIMM retaining clips from being easily opened and closed.



OM16882

Figure 17. Installing a DIMM

5. Make sure the clips at either end of the DIMM socket(s) are pushed outward to the open position.
6. Holding the DIMM by the edges, remove it from its anti-static package.
7. Position the DIMM above the socket. Align the small notch at the bottom edge of the DIMM with the keys in the socket (see inset in Figure 17).
8. Insert the bottom edge of the DIMM into the socket.
9. When the DIMM is inserted, push down on the top edge of the DIMM until the retaining clips snap into place. Make sure the clips are firmly in place.
10. Reinstall the PCI Express card if it was removed prior to installing the DIMMs.
11. Replace the computer's cover and reconnect the AC power cord.

Removing DIMMs

To remove a DIMM, follow these steps:

1. Observe the precautions in "Before You Begin" on page 27.
2. Turn off all peripheral devices connected to the computer. Turn off the computer.
3. Remove the AC power cord from the computer.
4. Remove the computer's cover.
5. Remove the PCI Express card if it interferes with the DIMM clips from being easily opened and closed.
6. Gently spread the retaining clips at each end of the DIMM socket. The DIMM pops out of the socket.
7. Hold the DIMM by the edges, lift it away from the socket, and store it in an anti-static package.
8. Reinstall the PCI Express card if you removed it before taking out the DIMMs.
9. Reinstall and reconnect any parts you removed or disconnected to reach the DIMM sockets.
10. Replace the computer's cover and reconnect the AC power cord.

Installing and Removing a PCI Express x16 Card



CAUTION

When installing any PCI Express card on the desktop board, ensure that it is fully seated in the PCI Express connector before you power on the system. If the card is not fully seated in the PCI Express connector, an electrical short may result across the PCI Express connector pins. Depending on the over-current protection of the power supply, certain board components and/or traces may be damaged.

Installing a PCI Express Card

1. Observe the precautions in "Before You Begin" on page 27.
2. Place the card in the PCI Express connector (Refer to the Intel Desktop Board D915PGN/D915PSY/D915PCY/D915PCM Quick Reference).
3. Press down on the card until it is completely seated in the PCI Express x16 connector and the card retention notch snaps into place around the retention mechanism (RM) pin.
4. Secure the card's metal bracket to the chassis back panel with a screw.

Removing the PCI Express Card

Follow these instructions to remove the PCI Express x16 card from the RM:

1. Observe the precautions in "Before You Begin" on page 27.
2. Remove the screw (see Figure 18, A) that secures the card's metal bracket to the chassis back panel.
3. Push back on the RM lever (see Figure 18, B) until the retention pin completely clears the notch in the card.
4. Pull the card straight up (see Figure 18, C).

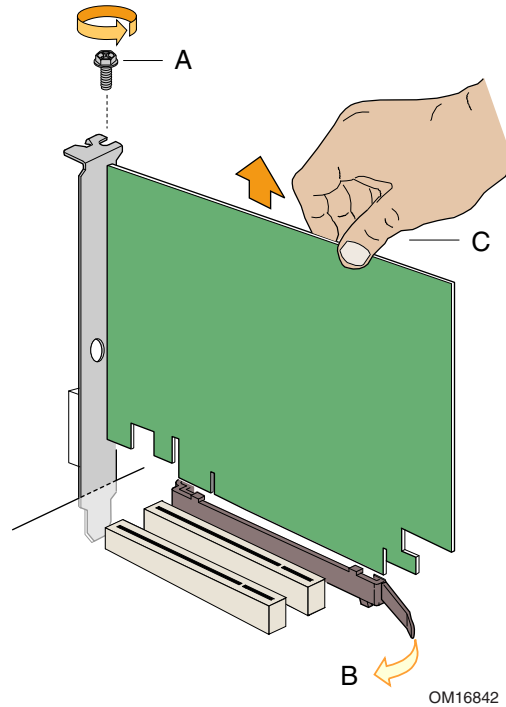

OM16842

Figure 18. Removing the PCI Express x16 Card

Connecting the IDE Cable

The IDE cable can connect two drives to the desktop board. The cable supports the ATA-66/100 transfer protocol. Figure 19 shows the correct installation of the cable.



NOTE

ATA-66/100 compatible cables are backward compatible with drives using slower IDE transfer protocols. If an ATA-66/100 disk drive and a disk drive using any other IDE transfer protocol are attached to the same cable, the maximum transfer rate between the drives may be reduced to that of the slowest drive.



NOTE

Do not connect an ATA device as a slave on the same IDE cable as an ATAPI master device. For example, do not connect an ATA hard drive as a slave to an ATAPI CD-ROM drive.

For correct function of the cable:

- Observe the precautions in "Before You Begin" on page 27.
- Attach the cable end with the single connector to the Intel desktop board (Figure 19, A).
- Attach the cable end with the two closely spaced connectors to the drives (Figure 19, B).

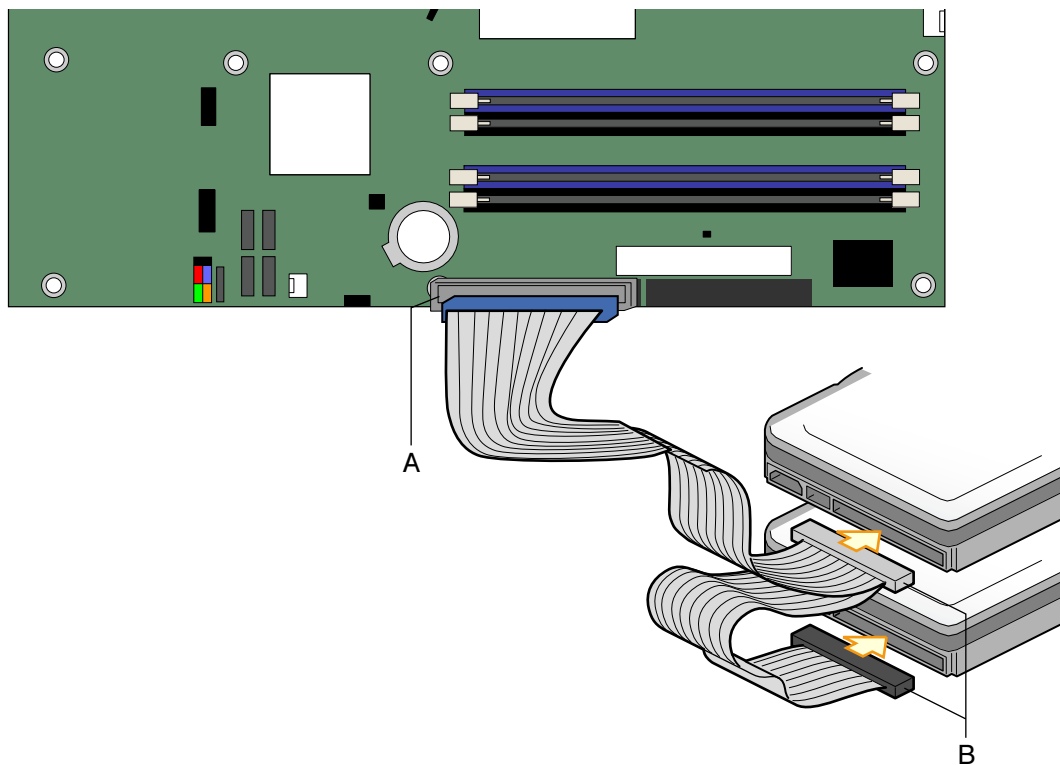

OM16883

Figure 19. Connecting the IDE Cable

Connecting the Serial ATA Cable

The SATA cable (4-conductor) supports the Serial ATA protocol and connects a single drive to the desktop board. Either end of the cable can be connected to the SATA drive or the connector on the board.

For correct cable function:

1. Observe the precaution in "Before You Begin" on page 27.
2. Attach either cable end to the connector (Figure 20, A) on the board.
3. Attach the other cable end to the drive (Figure 20, B).

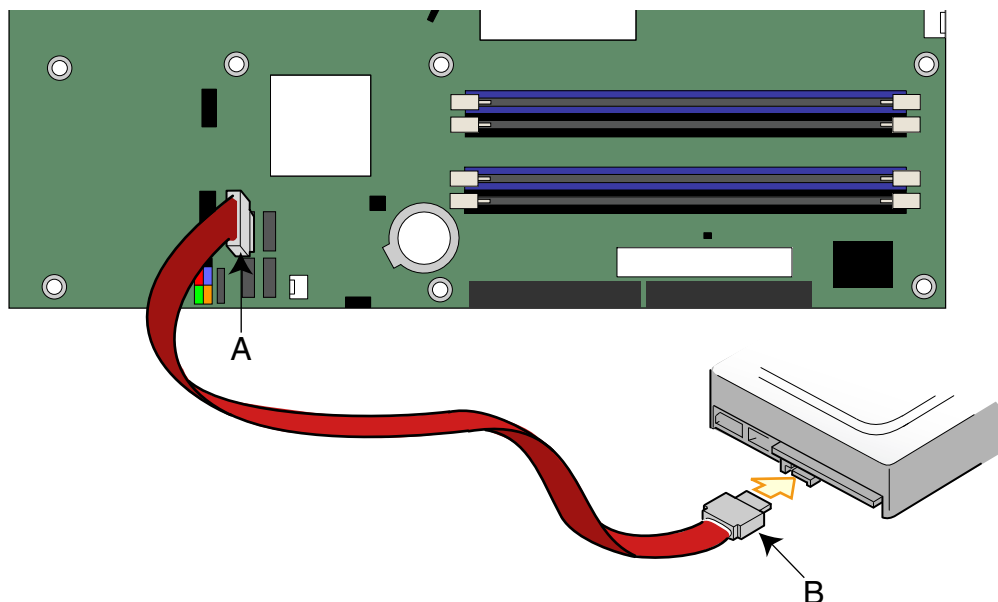

OM16884

Figure 20. Connecting the Serial ATA Cable

Connecting Internal Headers

Before connecting cables to the internal headers, observe the precautions in "Before You Begin" on page 27.

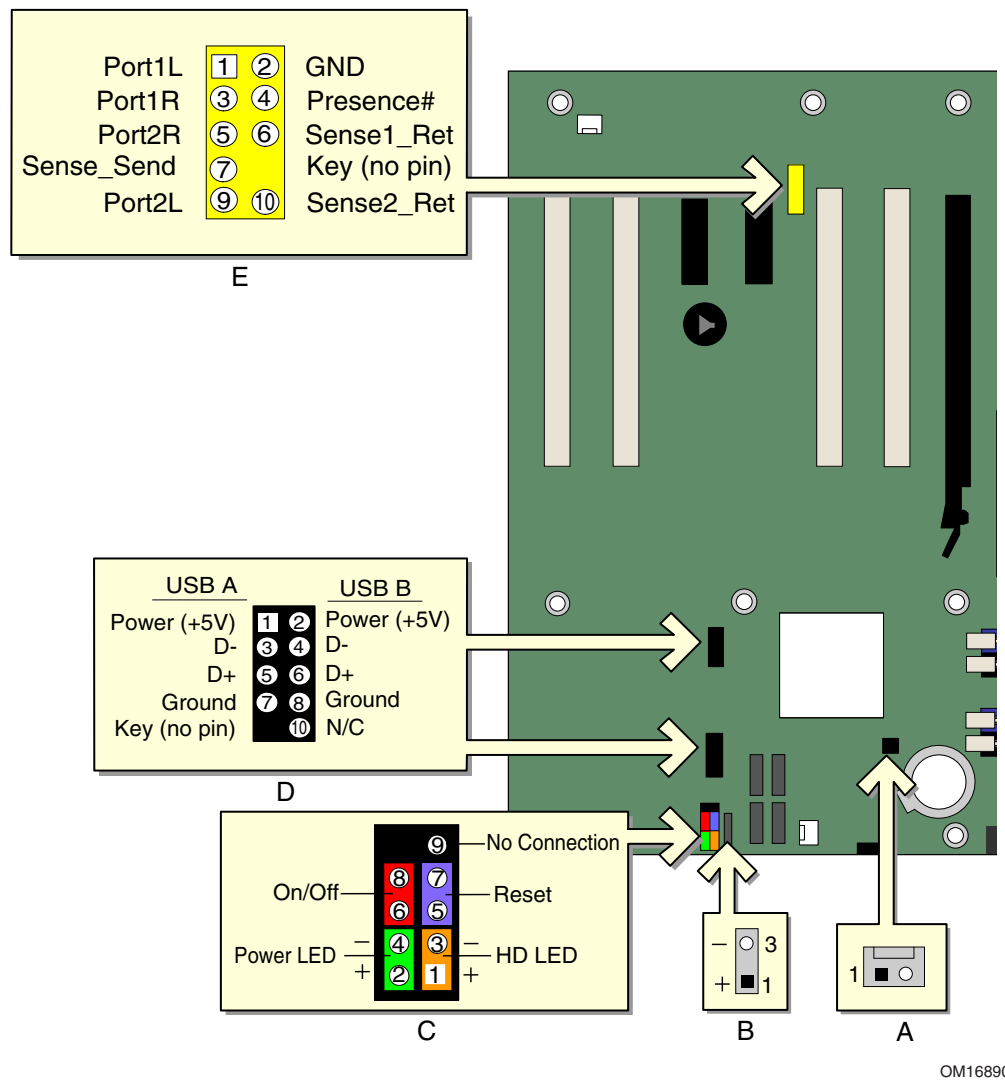

OM16890

Item	Description
A	Chassis intrusion
B	Power LED audio
C	Front panel
D	USB 2.0
E	Front panel audio

Figure 21. Internal Headers

Installing a Front Panel Audio Solution

Figure 21, E on page 44 shows the location of the yellow front panel audio header. Table 8 shows the pin assignments for the front panel audio header.

Table 8. Front Panel Audio Header Signal Names

Pin	Signal Name	Pin	Signal Name
1	Port1L	2	GND
3	Port1R	4	Presence#
5	Port2R	6	Sense1 Ret
7	Sense Send	8	Key (no pin)
9	Port2L	10	Sense2 Ret

To install the cable that connects the front panel audio solution to the front panel audio header, follow these steps:

1. Observe the precautions in "Before You Begin" on page 27.
2. Turn off all peripheral devices connected to the computer. Turn off the computer and disconnect the AC power cord.
3. Remove the cover.
4. Locate the yellow front panel audio header.
5. Install a correctly keyed and shielded front panel audio cable.
6. Connect the audio cable to the front panel audio solution.
7. Replace the cover.

To restore back panel audio, follow these steps:

1. Observe the precautions in "Before You Begin" on page 27.
2. Turn off all peripheral devices connected to the computer. Turn off the computer and disconnect the AC power cord.
3. Remove the cover.
4. Remove the front panel audio cable.
5. Replace the cover.

Connecting USB 2.0 Headers

Before connecting the USB 2.0 headers, observe the precautions in "Before You Begin" on page 27. See Figure 21, D for the location of the black USB 2.0 headers. Table 9 shows the pin assignments for the USB 2.0 headers.

Table 9. USB 2.0 Header Signal Names

USB Port A		USB Port B	
Pin	Signal Name	Pin	Signal Name
1	Power	2	Power
3	D-	4	D-
5	D+	6	D+
7	Ground	8	Ground
9	Key	10	No connect

Note: USB ports may be assigned as needed.

Connecting the Front Panel Header

Before connecting the front panel header, observe the precautions in "Before You Begin" on page 27. Figure 21, C on page 44 shows the location of the multi-colored front panel header. Table 10 shows the pin assignments for the front panel header.

Table 10. Front Panel Header Signal Names

Pin	Signal	In/Out	Description	Pin	Signal	In/Out	Description
Hard Drive Activity LED (Orange)				Power LED (Green)			
1	HD_PWR	Out	Hard disk LED pull-up (330 Ω) to +5 V	2	HDR_BLNK_GRN	Out	Front panel green LED
3	HDA#	Out	Hard disk active LED	4	HDR_BLNK_YEL	Out	Front panel yellow LED
Reset Switch (Purple)				On/Off Switch (Red)			
5	Ground		Ground	6	SWITCH_ON#	In	Power switch
7	FP_RESET#	In	Reset switch	8	Ground		Ground
9	+5 V	Out	Power	10	N/C		Not connected

Setting Up the Flexible 6-Channel Audio with Jack Re-tasking

After installing the Realtek audio driver from the Intel® Express Installer CD-ROM, the multi-channel audio feature can be enabled.

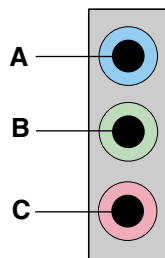

OM15694

Item	Description
A	Rear left/right out or Line In
B	Front left/right out
C	Center/LFE (Subwoofer) or Mic In

Figure 22. Back Panel Audio Connectors for Flexible 6-Channel Audio System

Multi-Channel Analog Audio

Connect two speakers to the front left/right out (B) and two speakers to the rear left/right out (A) for both 4- and 6-channel audio configurations. For 6-channel audio, connect two additional speakers to the center LFE out (C).

Connecting Fan and Power Cables

Connecting Fan Cables

See Figure 23 for fan locations. Connect the processor's fan heat sink cable to the 4-pin processor fan header on the board. Connect chassis fan cables to the 3-pin fan headers.

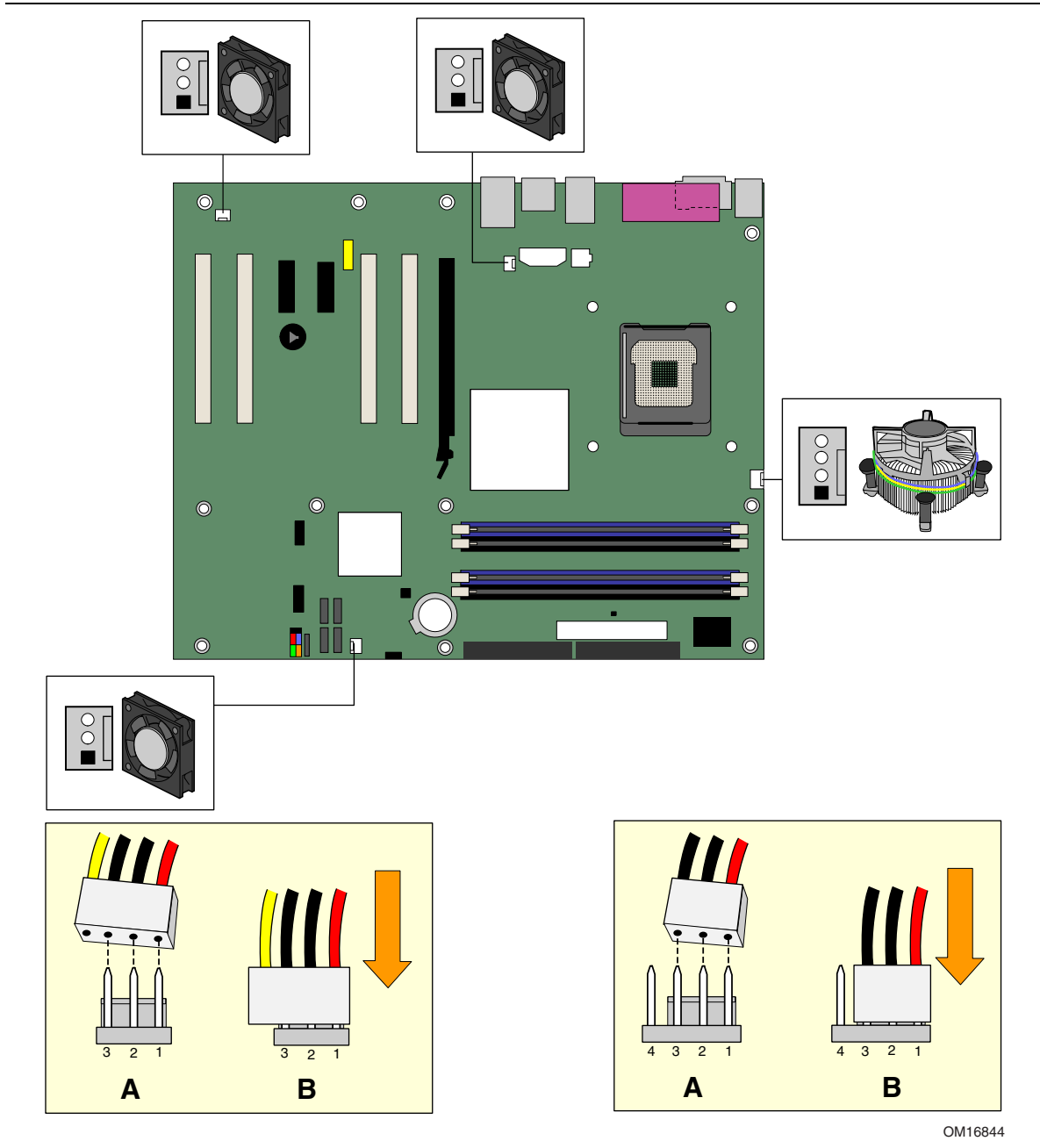

Figure 23. Location of Fan Headers

Connecting Power Cables



CAUTION

Failure to use an ATX12V power supply, or not connecting the 12 V (2x2) processor core voltage power supply connector to the desktop board may result in damage to the desktop board and/or power supply.

Connecting 2x10 Power Supply Cables

The 2x12 main power connector on the desktop board is backwards compatible with ATX12V power supplies with 2x10 power connections. Use of the 1x4 power connection is recommended with ATX12V power supplies with 2x10 connections when using PCI Express video cards that can consume up to 75 W. Figure 24 shows the location of the power connectors for a 2x10 power supply cable.

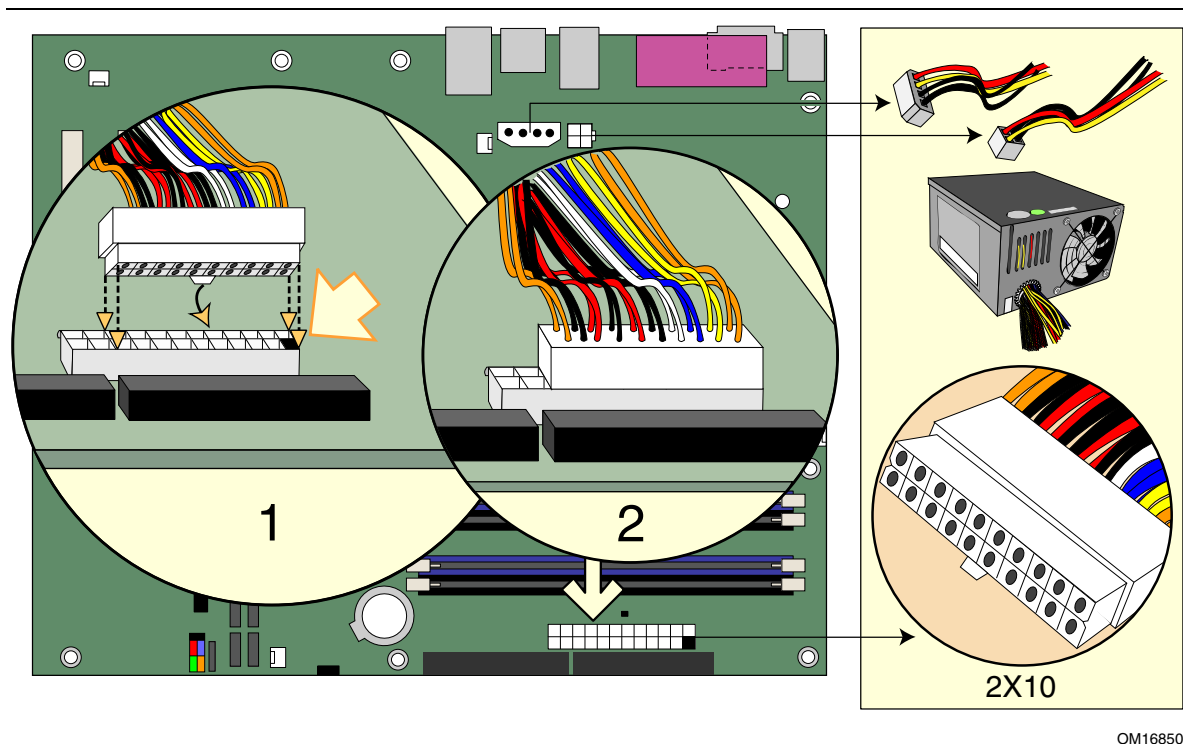

OM16850

Figure 24. Connecting 2x10 Power Supply Cables

1. Observe the precautions in "Before You Begin" on page 27.
2. Connect the 1x4 power supply cable to the 1x4 connector.
3. Connect the 12 V processor core voltage power supply cable to the 2x2 connector.
4. Connect the main power supply cable to the 2x10 connector.

Connecting 2x12 Power Supply Cables

If you have a 2x12 power supply, follow the instruction below. Figure 25 shows the location of the power connectors for a 2x12 power supply.

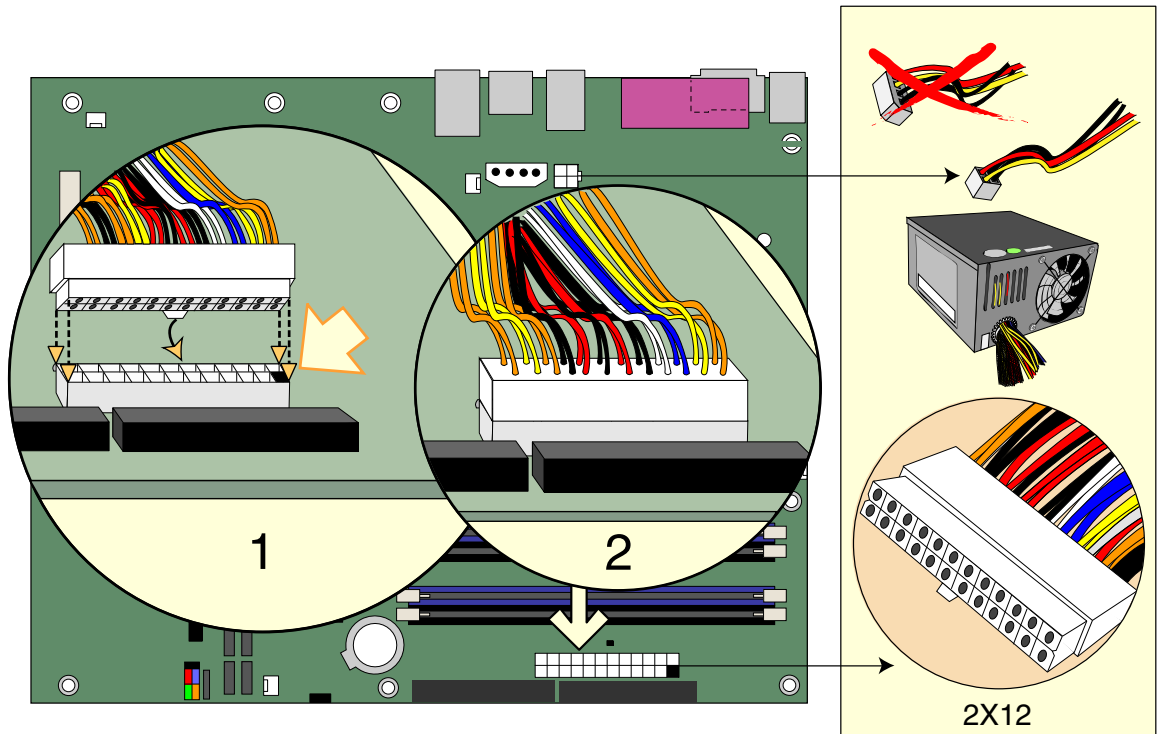

OM16851

Figure 25. Connecting 2x12 Power Supply Cables

1. Observe the precautions in "Before You Begin" on page 27.
2. Connect the 12 V processor core voltage power supply cable to the 2x2 connector.
3. Connect the main power supply cable to the 2x12 connector.

Add-In Card and Peripheral Interface Connectors

Figure 26 shows the location of the PCI bus add-in card connectors, PCI Express x16 and x1 add-in card connectors, and peripheral interface connectors for desktop boards D915PGN and D915PCY. Desktop boards D915PSY and D915PCM have two PCI bus add-in card connectors, one PCI Express x16 and one PCI Express x1 add-in card connector, and peripheral interface connectors.

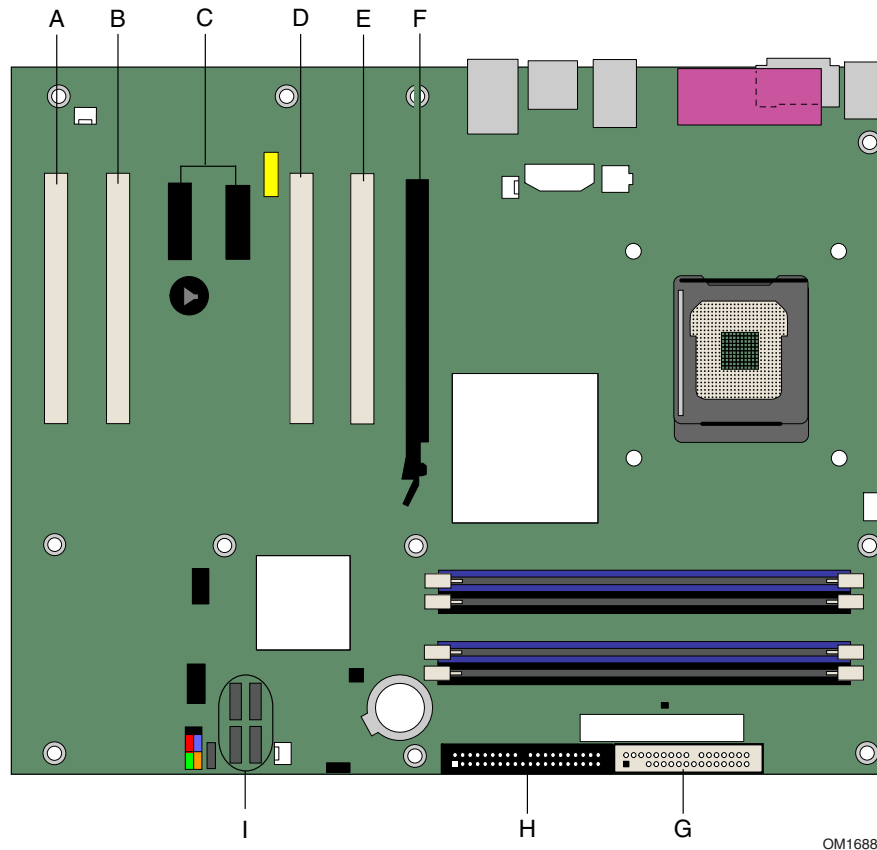

OM16889

Item	Description
A	PCI bus add-in card connector 4
B	PCI bus add-in card connector 3
C	PCI Express x1 connectors
D	PCI bus add-in card connector 2 (SMBus routed)
E	PCI bus add-in card connector 1
F	PCI Express x16 connector
G	Diskette drive connector
H	IDE connector
I	Serial ATA connectors

Figure 26. Location of the PCI Bus Add-in Card and Peripheral Interface Connectors for Desktop Boards D915PGN and D915PCY

Setting the BIOS Configuration Jumper Block



CAUTION

Always turn off the power and unplug the power cord from the computer before changing the jumper. Moving the jumper with the power on may result in unreliable computer operation.

The location of the desktop board's BIOS configuration jumper is shown in Figure 27.

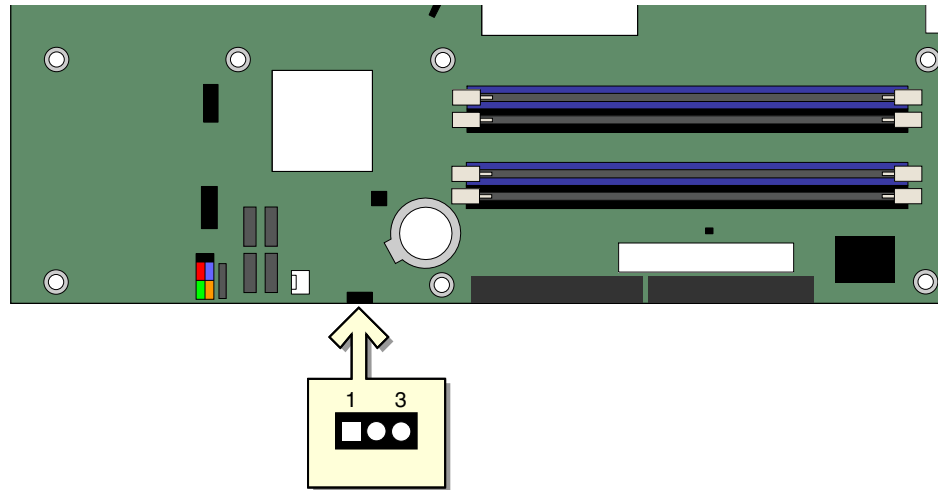



OM16885

Figure 27. Location of the BIOS Configuration Jumper Block

The three-pin BIOS jumper block enables all board configurations to be done in BIOS Setup. Table 11 shows the jumper settings for the Setup program modes.

Table 11. Jumper Settings for the BIOS Setup Program Modes

Jumper Setting	Mode	Description
	Normal (default) (1-2)	The BIOS uses the current configuration and passwords for booting.
	Configure (2-3)	After the Power-On Self-Test (POST) runs, the BIOS displays the Maintenance Menu. Use this menu to clear passwords.
	Recovery (None)	The BIOS recovers data from a recovery diskette in the event of a failed BIOS update.

Clearing Passwords

This procedure assumes that the board is installed in the computer and the configuration jumper block is set to normal mode.

1. Observe the precautions in "Before You Begin" on page 27.
2. Turn off all peripheral devices connected to the computer. Turn off the computer. Disconnect the computer's power cord from the AC power source (wall outlet or power adapter).
3. Remove the computer cover.
4. Find the configuration jumper block (see Figure 27).
5. Place the jumper on pins 2-3 as shown below.



6. Replace the cover, plug in the computer, turn on the computer, and allow it to boot.
7. The computer starts the Setup program. Setup displays the Maintenance menu.
8. Use the arrow keys to select Clear Passwords. Press <Enter> and Setup displays a pop-up screen requesting that you confirm clearing the password. Select Yes and press <Enter>. Setup displays the maintenance menu again.
9. Press <F10> to save the current values and exit Setup.
10. Turn off the computer. Disconnect the computer's power cord from the AC power source.
11. Remove the computer cover.
12. To restore normal operation, place the jumper on pins 1-2 as shown below.



13. Replace the cover, plug in the computer, and turn on the computer.

Back Panel Connectors



NOTE

The line out connector, located on the back panel, is designed to power either headphones or amplified speakers only. Poor audio quality may occur if passive (non-amplified) speakers are connected to this output.

Figure 28 shows the location of the back panel connectors.

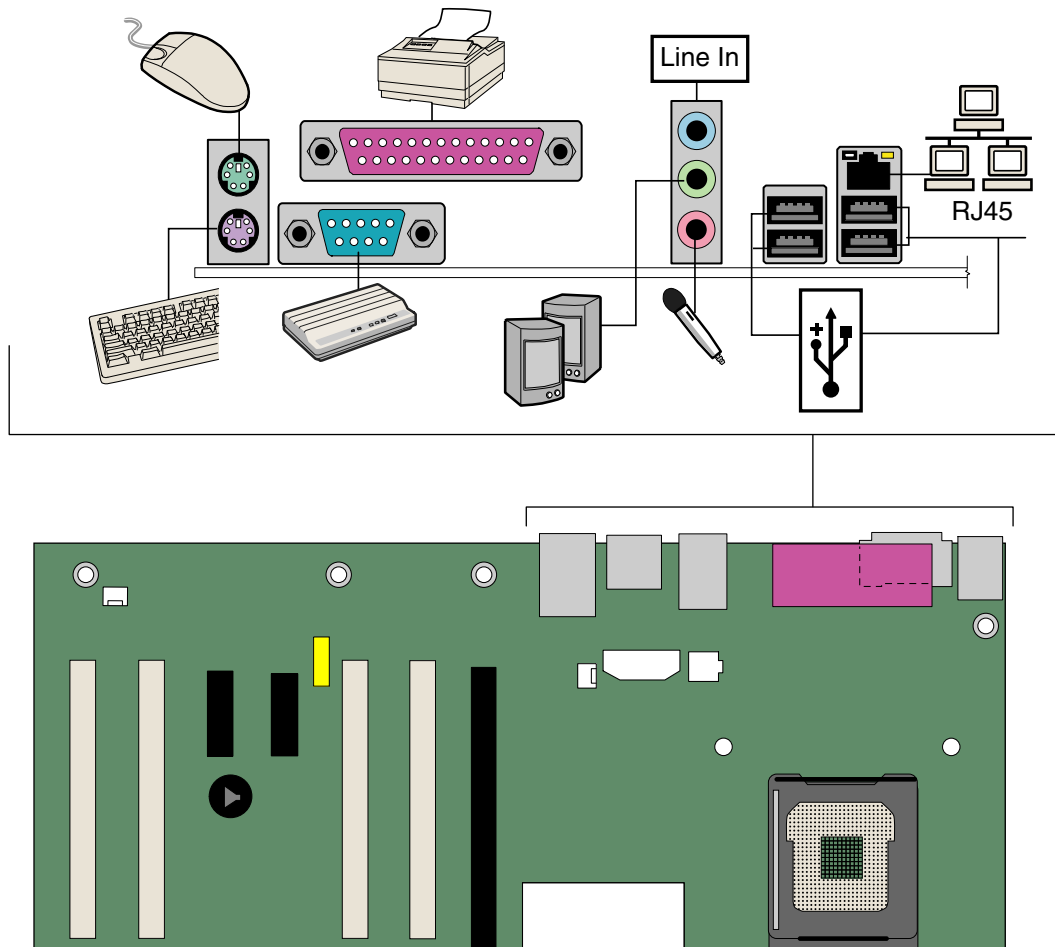

OM16887

Figure 28. Back Panel Connectors

Replacing the Battery

A coin-cell battery (CR2032) powers the real-time clock and CMOS memory. When the computer is not plugged into a wall socket, the battery has an estimated life of three years. When the computer is plugged in, the standby current from the power supply extends the life of the battery. The clock is accurate to ± 13 minutes/year at 25 °C with 3.3 VSB applied.

When the voltage drops below a certain level, the BIOS Setup program settings stored in CMOS RAM (for example, the date and time) might not be accurate. Replace the battery with an equivalent one. Figure 29 on page 58 shows the location of the battery.



CAUTION

Risk of explosion if the battery is replaced with an incorrect type. Batteries should be recycled where possible. Disposal of used batteries must be in accordance with local environmental regulations.



PRÉCAUTION

Risque d'explosion si la pile usagée est remplacée par une pile de type incorrect. Les piles usagées doivent être recyclées dans la mesure du possible. La mise au rebut des piles usagées doit respecter les réglementations locales en vigueur en matière de protection de l'environnement.



FORHOLDSREGEL

Eksplodingsfare, hvis batteriet erstattes med et batteri af en forkert type. Batterier bør om muligt genbruges. Bortskaffelse af brugte batterier bør foregå i overensstemmelse med gældende miljølovgivning.



OBS!

Det kan oppstå eksplosjonsfare hvis batteriet skiftes ut med feil type. Brukte batterier bør kastes i henhold til gjeldende miljølovgivning.



VIKTIGT!

Risk för explosion om batteriet ersätts med felaktig batterityp. Batterier ska kasseras enligt de lokala miljövårdsbestämmelserna.



VARO

Räjähdyksvaara, jos pariston tyyppi on väärä. Paristot on kierrätettävä, jos se on mahdollista. Käytetyt paristot on hävitettävä paikallisten ympäristömääräysten mukaisesti.



VORSICHT

Bei falschem Einsetzen einer neuen Batterie besteht Explosionsgefahr. Die Batterie darf nur durch denselben oder einen entsprechenden, vom Hersteller empfohlenen Batterietyp ersetzt werden. Entsorgen Sie verbrauchte Batterien den Anweisungen des Herstellers entsprechend.



AVVERTIMENTO

Esiste il pericolo di un esplosione se la pila non viene sostituita in modo corretto. Utilizzare solo pile uguali o di tipo equivalente a quelle consigliate dal produttore. Per disfarsi delle pile usate, seguire le istruzioni del produttore.



PRECAUCIÓN

Existe peligro de explosión si la pila no se cambia de forma adecuada. Utilice solamente pilas iguales o del mismo tipo que las recomendadas por el fabricante del equipo. Para deshacerse de las pilas usadas, siga igualmente las instrucciones del fabricante.



WAARSCHUWING

Er bestaat ontploffingsgevaar als de batterij wordt vervangen door een onjuist type batterij. Batterijen moeten zoveel mogelijk worden gerecycled. Houd u bij het weggooien van gebruikte batterijen aan de plaatselijke milieuwetgeving.



ATENÇÃO

Haverá risco de explosão se a bateria for substituída por um tipo de bateria incorreto. As baterias devem ser recicladas nos locais apropriados. A eliminação de baterias usadas deve ser feita de acordo com as regulamentações ambientais da região.



AŠCIAROŽNÁŠĆ

Існуе рызыка выбуху, калі заменены акумулятар непраўльнага тыпу. Акумулятары павінны, па магчымасці, перерацоўвацца. Пазбаўляцца ад старых акумулятараў патрэбна згодна з мясцовымі заканадаўствамі па экалогіі.



UPOZORNĚNÍ

V případě výměny baterie za nesprávný druh může dojít k výbuchu. Je-li to možné, baterie by měly být recyklovány. Baterie je třeba zlikvidovat v souladu s místními předpisy o životním prostředí.



Προσοχή

Υπάρχει κίνδυνος για έκρηξη σε περίπτωση που η μπαταρία αντικατασταθεί από μία λανθασμένου τύπου. Οι μπαταρίες θα πρέπει να ανακυκλώνονται όταν κάτι τέτοιο είναι δυνατό. Η απόρριψη των χρησιμοποιημένων μπαταριών πρέπει να γίνεται σύμφωνα με τους κατά τόπο περιβαλλοντικούς κανονισμούς.



VIGYAZAT

Ha a telepet nem a megfelelő típusú telepre cseréli, az felrobbanhat. A telepeket lehetőség szerint újra kell hasznosítani. A használt telepeket a helyi környezetvédelmi előírásoknak megfelelően kell kiselejtezni.



注意

異なる種類の電池を使用すると、爆発の危険があります。リサイクルが可能な地域であれば、電池をリサイクルしてください。使用後の電池を破棄する際には、地域の環境規制に従ってください。



AWAS

Risiko letupan wujud jika bateri digantikan dengan jenis yang tidak betul. Bateri sepatutnya dikitar semula jika boleh. Pelupusan bateri terpakai mestilah mematuhi peraturan alam sekitar tempatan.



OSTRZEŻENIE

Istnieje niebezpieczeństwo wybuchu w przypadku zastosowania niewłaściwego typu baterii. Zużyte baterie należy w miarę możliwości utylizować zgodnie z odpowiednimi przepisami ochrony środowiska.



PRECAUȚIE

Risc de explozie, dacă bateria este înlocuită cu un tip de baterie necorespunzător. Bateriile trebuie reciclate, dacă este posibil. Depozitarea bateriilor uzate trebuie să respecte reglementările locale privind protecția mediului.



ВНИМАНИЕ

При использовании батареи несоответствующего типа существует риск ее взрыва. Батареи должны быть утилизированы по возможности. Утилизация батарей должна проводиться по правилам, соответствующим местным требованиям.



UPOZORNENIE

Ak batériu vymeníte za nesprávny typ, hrozí nebezpečenstvo jej výbuchu. Batérie by sa mali podľa možnosti vždy recyklovať. Likvidácia použitých batérií sa musí vykonávať v súlade s miestnymi predpismi na ochranu životného prostredia.



POZOR

Zamenjava baterije z baterijo drugačnega tipa lahko povzroči eksplozijo. Če je mogoče, baterije reciklirajte. Rabljene baterije zavrzite v skladu z lokalnimi okoljevarstvenimi predpisi.



การระวัง

ระวังการระเบิดที่เกิดจากเปลี่ยนแบตเตอรี่ผิดประเภท หากเป็นไปได้ ควรนำแบตเตอรี่ไปรีไซเคิล การทิ้งแบตเตอรี่ใช้แล้วต้องเป็นไปตามกฎข้อบังคับด้านสิ่งแวดล้อมของท้องถิ่น.



UYARI

Yanlış türde pil takıldığında patlama riski vardır. Piller mümkün olduğunda geri dönüştürülmelidir. Kullanılmış piller, yerel çevre yasalarına uygun olarak atılmalıdır.



ОСТОРОГА

Використовуйте батареї правильного типу, інакше існуватиме ризик вибуху. Якщо можливо, використані батареї слід утилізувати. Утилізація використаних батарей має бути виконана згідно місцевих норм, що регулюють охорону довкілля.

To replace the battery, follow these steps:

1. Observe the precautions in "Before You Begin" (see page 27).
2. Turn off all peripheral devices connected to the computer. Disconnect the computer's power cord from the AC power source (wall outlet or power adapter).
3. Remove the computer cover.
4. Locate the battery on the board (see Figure 29).
5. With a medium flat-bladed screwdriver, gently pry the battery free from its connector. Note the orientation of the "+" and "-" on the battery.
6. Install the new battery in the connector, orienting the "+" and "-" correctly.
7. Replace the computer cover.

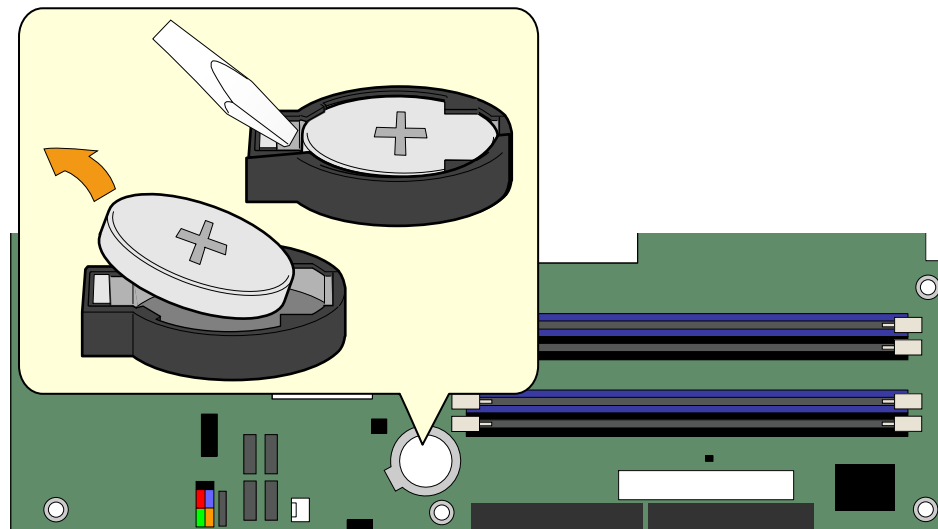

OM16886

Figure 29. Removing the Battery

3 BIOS

The BIOS Setup program can be used to view and change the BIOS settings for the computer. The BIOS Setup program is accessed by pressing the <F2> key after the Power-On Self-Test (POST) memory test begins and before the operating system boot begins.

Updating the BIOS with the Intel® Express BIOS Update Utility

With the Intel Express BIOS Update utility you can update the system BIOS while in the Windows environment. The BIOS file is included in an automated update utility that combines the functionality of the Intel® Flash Memory Update Utility and the ease-of use of Windows-based installation wizards.

To update the BIOS with the Intel Express BIOS Update utility:

1. Go to the Intel World Wide Web site:
<http://support.intel.com/support/motherboards/desktop/>
2. Navigate to the D915PGN/D915PSY/D915PCY/D915PCM page, click “[view] Latest BIOS updates,” and select the Express BIOS Update utility file.
3. Download the file to your hard drive. (You can also save this file to a diskette. This is useful if you are updating the BIOS for multiple identical systems.)
4. Close all other applications. This step is required. Your system will be rebooted at the last Express BIOS Update window.
5. Double-click the executable file from the location on your hard drive where it was saved. This runs the update program.
6. Follow the instructions provided in the dialog boxes to complete the BIOS update.

Updating the BIOS with the Iflash Memory Update Utility

With the Iflash BIOS update utility you can update the system BIOS from a floppy disk or other bootable media. The utility available from the Web provides a simple method for creating a bootable flash memory update floppy that will automatically update your BIOS.

Obtaining the BIOS Update File

You can update to a new version of the BIOS by using the BIOS update file. The BIOS update file is a compressed self-extracting archive that contains all the files you need to update the BIOS. The BIOS update file contains:

- New BIOS files
- BIOS recovery files
- Intel Flash Memory Update Utility

You can obtain the BIOS update file through your computer supplier or by navigating to the Desktop Board D915PGN/D915PSY/D915PCY/D915PCM page on the Intel World Wide Web site at:

<http://support.intel.com/support/motherboards/desktop>

Navigate to the D915PGN/D915PSY/D915PCY/D915PCM page, click “[view] Latest BIOS updates,” and select the Iflash BIOS Update utility file.



NOTE

Review the instructions distributed with the update utility before attempting a BIOS update.

The Iflash Memory Update utility allows you to:

- Update the BIOS in flash memory
- Update the language section of the BIOS

Updating the BIOS



CAUTION

The AUTOEXEC.BAT file provided with the update files updates the BIOS. Do not interrupt the process or the system may not function.

1. Boot the computer with the BIOS update diskette in drive A. During system boot, the AUTOEXEC.BAT file provided with the update files will automatically run the BIOS update process.
2. When the update process is complete, the monitor will display a message telling you to remove the diskette and to reboot the system.
3. As the computer boots, check the BIOS identifier (version number) to make sure the update was successful. If a logo appears, press <Esc> to view the POST messages.

Recovering the BIOS

It is unlikely that anything will interrupt the BIOS update; however, if an interruption occurs, the BIOS could be damaged. The following steps explain how to recover the BIOS if an update fails. The following procedure uses recovery mode for the Setup program. See page 52 for more information on Setup modes.



NOTE

Because of the small amount of code available in the boot block area, there is no video support. You will not see anything on the screen during this procedure. Monitor the procedure by listening to the speaker and looking at the diskette drive LED.

1. Turn off the computer, disconnect the computer's power cord, and disconnect all external peripherals.
2. Remove the computer cover and locate the configuration jumper block (see Figure 27).

3. Remove the jumper from all pins as shown below to set recovery mode for Setup.



4. Insert the bootable BIOS update diskette into diskette drive A.
5. Replace the computer cover, connect the power cord, turn on the computer, and allow it to boot. The recovery process will take a few minutes.
6. Listen to the speaker:
 - Upon applying power, drive A will begin to show activity. In about a minute, two beeps are heard and drive A activity ceases (temporarily) indicating the successful recovery of the BIOS core. Drive A activity will begin again followed by two more beeps indicating the successful recovery of the boot block. This sequence of events indicates a successful BIOS recovery.
 - A series of continuous beeps indicates a failed BIOS recovery.
7. If recovery fails, return to step 1 and repeat the recovery process.
8. If recovery is successful, turn off the computer, and disconnect its power cord.
9. Remove the computer cover and continue with the following steps.
10. On the jumper block, reinstall the jumper back on pins 1-2 as shown below to set normal mode for Setup.



11. Leave the update diskette in drive A, replace the computer cover, and connect the computer's power cord.
12. Turn on the computer and continue with the BIOS update.

4 Desktop Board Resources

Memory Map

Table 12. System Memory Map

Address Range (decimal)	Address Range (hex)	Size	Description
1024 K - 4194304 K	100000 - FFFFFFFF	4095 MB	Extended Memory
960 K - 1024 K	F0000 - FFFFF	64 KB	Runtime BIOS
896 K - 960 K	E0000 - EFFFF	64 KB	Reserved
800 K - 896 K	C8000 - DFFFF	96 KB	Available high DOS memory (open to the PCI bus)
640 K - 800 K	A0000 - C7FFF	160 KB	Video memory and BIOS
639 K - 640 K	9FC00 - 9FFFF	1 KB	Extended BIOS data (movable by memory manager software)
512 K - 639 K	80000 - 9FBFF	127 KB	Extended conventional memory
0 K - 512 K	00000 - 7FFFF	512 KB	Conventional memory

DMA Channels

Table 13. DMA Channels

DMA Channel Number	Data Width	System Resource
0	8 or 16 bits	Open
1	8 or 16 bits	Parallel port
2	8 or 16 bits	Floppy drive
3	8 or 16 bits	Parallel port (for ECP or EPP)
4	8 or 16 bits	DMA controller
5	16 bits	Open
6	16 bits	Open
7	16 bits	Open

Interrupts

Table 14. Interrupts

IRQ	System Resource
NMI	I/O channel check
0	Reserved, interval timer
1	Reserved, keyboard buffer full
2	Reserved, cascade interrupt from slave PIC
3	COM2*
4	COM1*
5	LPT2 (Plug and Play option) / **
6	Floppy drive controller
7	LPT1*
8	Real time clock
9	**
10	**
11	**
12	Onboard mouse port (if present, else user available)
13	Reserved, math coprocessor
14	Primary IDE/Serial ATA (if present, else user available)
15	Secondary IDE/Serial ATA (if present, else user available)

* Default, but can be changed to another IRQ.

** Dynamically allocated for all PCI/PCI Express devices and slots.

A Error Messages and Indicators

Desktop Board D915PGN/D915PSY/D915PCY/D915PCM reports POST errors in two ways:

- By sounding a beep code
- By displaying an error message on the monitor

BIOS Beep Codes

The BIOS beep codes are listed in Table 15. The BIOS also issues a beep code (one long tone followed by two short tones) during POST if the video configuration fails (a faulty video card or no card installed) or if an external ROM module does not properly checksum to zero.

Table 15. Beep Codes

Number of Beeps	Description
1	Refresh failure
2	Parity cannot be reset
3	First 64 K memory failure
4	Timer not operational
5	Processor failure (Reserved; not used)
6	8042 GateA20 cannot be toggled (memory failure or not present)
7	Exception interrupt error
8	Display memory R/W error
9	(Reserved; not used)
10	CMOS Shutdown register test error
11	Invalid BIOS (such as, POST module not found)

BIOS Error Messages

When a recoverable error occurs during the POST, the BIOS displays an error message describing the problem.

Table 16. BIOS Error Messages

Error Message	Explanation
GA20 Error	An error occurred with Gate-A20 when switching to protected mode during the memory test.
Pri Master HDD Error Pri Slave HDD Error Sec Master HDD Error Sec Slave HDD Error	Could not read sector from corresponding drive.
Pri Master Drive - ATAPI Incompatible Pri Slave Drive - ATAPI Incompatible Sec Master Drive - ATAPI Incompatible Sec Slave Drive - ATAPI Incompatible	Corresponding drive is not an ATAPI device. Run Setup to make sure device is selected correctly.
A: Drive Error B: Drive Error	No response from the diskette drive.
CMOS Battery Low	The battery may be losing power. Replace the battery soon.
CMOS Display Type Wrong	The display type is different than what has been stored in CMOS. Check Setup to make sure type is correct.
CMOS Checksum Bad	The CMOS checksum is incorrect. CMOS memory may have been corrupted. Run Setup to reset values.
CMOS Settings Wrong	CMOS values are not the same as the last boot. These values have either been corrupted or the battery has failed.
CMOS Date/Time Not Set	The time and/or date values stored in CMOS are invalid. Run Setup to set correct values.
DMA Error	Error during read/write test of DMA controller.
FDC Failure	Error occurred trying to access diskette drive controller.
HDC Failure	Error occurred trying to access hard disk controller.
Checking NVRAM.....	NVRAM is being checked to see if it is valid.
Update OK!	NVRAM was invalid and has been updated.
Updated Failed	NVRAM was invalid but was unable to be updated.
Keyboard Is Locked	The system keyboard lock is engaged. The system must be unlocked to continue to boot.
Keyboard Error	Error in the keyboard connection. Make sure keyboard is connected properly.
KB/Interface Error	Keyboard interface test failed.

continued

Table 16. BIOS Error Messages (continued)

Error Message	Explanation
Memory Size Decreased	Memory size has decreased since the last boot. If no memory was removed, then memory may be bad.
Memory Size Increased	Memory size has increased since the last boot. If no memory was added, there may be a problem with the system.
Memory Size Changed	Memory size has changed since the last boot. If no memory was added or removed, then memory may be bad.
No Boot Device Available	System did not find a device to boot.
Off Board Parity Error	A parity error occurred on an offboard card. This error is followed by an address.
On Board Parity Error	A parity error occurred in onboard memory. This error is followed by an address.
Parity Error	A parity error occurred in onboard memory at an unknown address.
NVRAM / CMOS / PASSWORD cleared by Jumper	NVRAM, CMOS, and passwords have been cleared. The system should be powered down and the jumper removed.
<CTRL_N> Pressed	CMOS is ignored and NVRAM is cleared. User must enter Setup.

B Regulatory Compliance

This appendix contains the following regulatory compliance information for Desktop Board D915PGN/D915PSY/D915PCY/D915PCM:

- Safety regulations
- European Union Declaration of Conformity statement
- Product Ecology statements
- Electromagnetic Compatibility (EMC) regulations
- Product certification markings

Safety Regulations

Desktop Board D915PGN/D915PSY/D915PCY/D915PCM complies with the safety regulations stated in Table 17 when correctly installed in a compatible host system.

Table 17. Safety Regulations

Regulation	Title
UL 60950-1:2003/ CSA C22.2 No. 60950-1-03	Information Technology Equipment – Safety - Part 1: General Requirements (USA and Canada)
EN 60950-1:2002	Information Technology Equipment – Safety - Part 1: General Requirements (European Union)
IEC 60950-1:2001, First Edition	Information Technology Equipment – Safety - Part 1: General Requirements (International)

European Union Declaration of Conformity Statement

We, Intel Corporation, declare under our sole responsibility that the product Intel® Desktop Board D915PGN/D915PSY/D915PCY/D915PCM is in conformity with all applicable essential requirements necessary for CE marking, following the provisions of the European Council Directive 89/336/EEC (EMC Directive) and Council Directive 73/23/EEC (Safety/Low Voltage Directive).

The product is properly CE marked demonstrating this conformity and is for distribution within all member states of the EU with no restrictions.



This product follows the provisions of the European Directives 89/336/EEC and 73/23/EEC.

Dansk Dette produkt er i overensstemmelse med det europæiske direktiv 89/336/EEC & 73/23/EEC.

Dutch Dit product is in navolging van de bepalingen van Europees Directief 89/336/EEC & 73/23/EEC.

Suomi Tämä tuote noudattaa EU-direktiivin 89/336/EEC & 73/23/EEC määräyksiä.

Français Ce produit est conforme aux exigences de la Directive Européenne 89/336/EEC & 73/23/EEC.

Deutsch Dieses Produkt entspricht den Bestimmungen der Europäischen Richtlinie 89/336/EEC & 73/23/EEC.

Icelandic Þessi vara stenst reglugerð Evrópska Efnahags Bandalagsins númer 89/336/EEC & 73/23/EEC.

Italiano Questo prodotto è conforme alla Direttiva Europea 89/336/EEC & 73/23/EEC.

Norsk Dette produktet er i henhold til bestemmelsene i det europeiske direktivet 89/336/EEC & 73/23/EEC.

Portuguese Este produto cumpre com as normas da Diretiva Europeia 89/336/EEC & 73/23/EEC.

Español Este producto cumple con las normas del Directivo Europeo 89/336/EEC & 73/23/EEC.

Svenska Denna produkt har tillverkats i enlighet med EG-direktiv 89/336/EEC & 73/23/EEC.

Product Ecology Statements

The following information is provided to address worldwide product ecology concerns and regulations.

Disposal Considerations

This product contains the following materials that may be regulated upon disposal: lead solder on the printed wiring board assembly.

Recycling Considerations

Intel encourages its customers to recycle its products and their components (e.g., batteries, circuit boards, plastic enclosures, etc.) whenever possible. In the U.S., a list of recyclers in your area can be found at:

<http://www.eiae.org>

In the absence of a viable recycling option, products and their components must be disposed of in accordance with all applicable local environmental regulations.

EMC Regulations

Desktop Board D915PGN/D915PSY/D915PCY/D915PCM complies with the EMC regulations stated in Table 18 when correctly installed in a compatible host system.

Table 18. EMC Regulations

Regulation	Title
FCC Class B	Title 47 of the Code of Federal Regulations, Parts 2 and 15, Subpart B, Radio Frequency Devices. (USA)
ICES-003 (Class B)	Interference-Causing Equipment Standard, Digital Apparatus. (Canada)
EN55022: 1998 (Class B)	Limits and methods of measurement of Radio Interference Characteristics of Information Technology Equipment. (European Union)
EN55024: 1998	Information Technology Equipment – Immunity Characteristics Limits and methods of measurement. (European Union)
AS/NZS 3548 (Class B)	Australian Communications Authority, Standard for Electromagnetic Compatibility. (Australia and New Zealand)
CISPR 22, 3 rd Edition, (Class B)	Limits and methods of measurement of Radio Disturbance Characteristics of Information Technology Equipment. (International)
CISPR 24: 1997	Information Technology Equipment – Immunity Characteristics – Limits and Methods of Measurement. (International)
VCCI (Class B)	Voluntary Control for Interference by Information Technology Equipment (Japan)

Japanese Kanji statement translation: This is a Class B product based on the standard of the Voluntary Control Council for Interference from Information Technology Equipment (VCCI). If this is used near a radio or television receiver in a domestic environment, it may cause radio interference. Install and use the equipment according to the instruction manual.

この装置は、情報処理装置等電波障害自主規制協議会（VCCI）の基準に基づくクラスB情報技術装置です。この装置は、家庭環境で使用することを目的としていますが、この装置がラジオやテレビジョン受信機に近接して使用されると、受信障害を引き起こすことがあります。
取扱説明書に従って正しい取り扱いをして下さい。





Korean Class B statement translation: This is household equipment that is certified to comply with EMC requirements. You may use this equipment in residential environments and other non-residential environments.

이 기기는 가정용으로 전자파적합등록을 한 기기로서 주거지역에서는 물론 모든 지역에서 사용할 수 있습니다.

Product Certification Markings (Board Level)

Desktop Board D915PGN/D915PSY/D915PCY/D915PCM has the following product certification markings:

Table 19. Product Certification Markings

Description	Mark
UL joint US/Canada Recognized Component mark. Includes adjacent UL file number for Intel desktop boards: E210882 (component side).	
FCC Declaration of Conformity logo mark for Class B equipment; includes Intel name and D915PGN/D915PSY/D915PCY/D915PCM model designation (component side).	
CE mark. Declares compliance to European Union (EU) EMC directive (89/336/EEC) and Low Voltage directive (73/23/EEC) (component side). The CE mark should also be on the shipping container.	
Australian Communications Authority (ACA) C-tick mark. Includes adjacent Intel supplier code number, N-232. The C-tick mark should also be on the shipping container.	
Printed wiring board manufacturer's recognition mark: consists of a unique UL recognized manufacturer's logo, along with a flammability rating (solder side).	V-0 or 94V-0