

Intel[®] Server Board SE7230NH1-E and Intel[®] Server Platform SR1475NH1-E User's Guide

Intel Order Number D23185-005

Disclaimer

Information in this document is provided in connection with Intel® products. No license, express or implied, by estoppel or otherwise, to any intellectual property rights is granted by this document. Except as provided in Intel's Terms and Conditions of Sale for such products, Intel assumes no liability whatsoever, and Intel disclaims any express or implied warranty, relating to sale and/or use of Intel products including liability or warranties relating to fitness for a particular purpose, merchantability, or infringement of any patent, copyright or other intellectual property right. Intel products are not designed, intended or authorized for use in any medical, life saving, or life sustaining applications or for any other application in which the failure of the Intel product could create a situation where personal injury or death may occur. Intel may make changes to specifications and product descriptions at any time, without notice.

Intel server boards contain a number of high-density VLSI and power delivery components that need adequate airflow for cooling. Intel's own chassis are designed and tested to meet the intended thermal requirements of these components when the fully integrated system is used together. It is the responsibility of the system integrator that chooses not to use Intel developed server building blocks to consult vendor datasheets and operating parameters to determine the amount of airflow required for their specific application and environmental conditions. Intel Corporation can not be held responsible if components fail or the server board does not operate correctly when used outside any of their published operating or non-operating limits.

Intel, Intel Pentium, and Intel Xeon are trademarks or registered trademarks of Intel Corporation or its subsidiaries in the United States and other countries.

* Other names and brands may be claimed as the property of others.

Copyright © 2005-2007, Intel Corporation. All Rights Reserved

Preface

About this Manual

Thank you for purchasing and using the Intel® Server Board SE7230NH1-E.

This manual is written for system technicians who are responsible for troubleshooting, upgrading, and repairing this server board. This document provides a brief overview of the features of the board/chassis, a list of accessories or other components you may need, troubleshooting information, and instructions on how to add and replace components on the Intel Server Board SE7230NH1-E User Guide. For the latest version of this manual, refer to <http://support.intel.com/support/motherboards/server/SE7230NH1-E/>.

Manual Organization

Chapter 1 provides a brief overview of the Server Board SE7230NH1-E. In this chapter, you will find a list of the server board features, drawings of the product, and product diagrams to help you identify components and their locations.

Chapter 2 provides instructions on using the utilities that are shipped with the board or that may be required to update the system. This includes how to navigate through the BIOS Setup screens, how to perform a BIOS update, and how to reset CMOS. Information about the specific BIOS settings and screens is available in the Technical Product Specification. See "[Additional Information and Software](#)" for a link to the Technical Product Specification.

Chapter 3 provides instructions on adding and replacing components. Use this chapter for step-by-step instructions and diagrams for installing or replacing components such as the memory, processor, control panel board, and the battery, among other components.

Chapter 4 provides troubleshooting information. In this chapter, you will find BIOS error messages and POST code messages. You will also find suggestions for performing troubleshooting activities to identify the source of a problem.

Product Accessories

This server board is compatible with the following Intel® Server Chassis:

- Intel® Server Chassis SR1475
- Intel® Server Platform SR1475NH1-E

You may need or want to purchase one or more of the following accessory items for your server:

Processor, memory DIMMs, hard drive, floppy drive, CD-ROM or DVD-ROM drive, RAID controller, operating system.

For information about which accessories, memory, processors, and third-party hardware have been tested and can be used with your board, and for ordering information for Intel products, see <http://support.intel.com/support/motherboards/server/SE7230NH1-E/compat.htm>.

Additional Information and Software

If you need more information about this product or information about the accessories that can be used with this server board, use the following resources. These files are available at <http://support.intel.com/support/motherboards/server/SE7230NH1-E/>

Unless otherwise indicated in the table below, once on this Web page, type the document or software name in the search field at the left side of the screen and select the option to search "SE7230NH1-E".

For this information or software	Use this Document or Software
For in-depth technical information about this product, including BIOS settings and chipset information	Intel® Server Board SE7230NH1-E Technical Product Specification
If you just received this product and need to install it	Intel® Server Board SE7230NH1-E Quick Start User's Guide in the product box
For virtual system tours and interactive repair information	A link to the SMaRT Tool is available under "Other Resources" at the right side of the screen at http://support.intel.com/support/motherboards/server/SE7230NH1-E
Accessories or other Intel server products	Spares and Configuration Guide
Hardware (peripheral boards, adapter cards) and operating systems that have been tested with this product	Tested Hardware Operating Systems List
Chassis that have been tested with this product	Reference Chassis List
Processors that have been tested with this product	Supported Processors
DIMMs that have been tested with this product	Tested Memory List
To make sure your system falls within the allowed power budget	Power Budget Tool

For software to manage your Intel® server	Intel Server Management Software
For drivers	Driver (for an extensive list of drivers available) Operating System Driver (for operating system drivers)
For firmware and BIOS updates, or BIOS recovery	Firmware Updates
For diagnostics test software	Diagnostics See also the Intel® Server Deployment Toolkit CD that came with your server board

Safety Information

Important Safety Instructions

Read all caution and safety statements in this document before performing any of the instructions. See also Intel Server Boards and Server Chassis Safety Information on the *Intel® Server Deployment Toolkit CD* and/or at <http://support.intel.com/support/motherboards/server/sb/cs-010770.htm>.

Wichtige Sicherheitshinweise

Lesen Sie zunächst sämtliche Warnung und Sicherheitshinweise in diesem Dokument, bevor Sie eine der Anweisungen ausführen. Beachten Sie hierzu auch die Sicherheitshinweise zu Intel-Serverplatinen und Servergehäusen auf der *Intel® Server Deployment Toolkit CD* oder unter <http://support.intel.com/support/motherboards/server/sb/cs-010770.htm>.

Consignes de sécurité

Lisez attention toutes les consignes de sécurité et les mises en garde indiquées dans ce document avant de suivre toute instruction. Consultez Intel Server Boards and Server Chassis Safety Information sur le *Intel® Server Deployment Toolkit CD* ou bien rendez-vous sur le site <http://support.intel.com/support/motherboards/server/sb/cs-010770.htm>.

Instrucciones de seguridad importantes

Lea todas las declaraciones de seguridad y precaución de este documento antes de realizar cualquiera de las instrucciones. Vea Intel Server Boards and Server Chassis Safety Information en el *Intel® Server Deployment Toolkit CD* y/o en <http://support.intel.com/support/motherboards/server/sb/cs-010770.htm>.

重要安全指导

在执行任何指令之前，请阅读本文档中的所有注意事项及安全声明。和/或 <http://support.intel.com/support/motherboards/server/safecert.htm> 上的 *Intel Server Boards and Server Chassis Safety Information* (《Intel 服务器主板与服务器机箱安全信息》)。

Warnings

Heed safety instructions: Before working with your server product, whether you are using this guide or any other resource as a reference, pay close attention to the safety instructions. You must adhere to the assembly instructions in this guide to ensure and maintain compliance with existing product certifications and approvals. Use only the described, regulated components specified in this guide. Use of other products / components will void the UL listing and other regulatory approvals of the product and will most likely result in noncompliance with product regulations in the region(s) in which the product is sold.

System power on/off: The power button DOES NOT turn off the system AC power. To remove power from system, you must unplug the AC power cord from the wall outlet. Make sure the AC power cord is unplugged before you open the chassis, add, or remove any components.

Hazardous conditions, devices and cables: Hazardous electrical conditions may be present on power, telephone, and communication cables. Turn off the server and disconnect the power cord, telecommunications systems, networks, and modems attached to the server before opening it. Otherwise, personal injury or equipment damage can result.

Electrostatic discharge (ESD) and ESD protection: ESD can damage disk drives, boards, and other parts. We recommend that you perform all procedures in this chapter only at an ESD workstation. If one is not available, provide some ESD protection by wearing an antistatic wrist strap attached to chassis ground any unpainted metal surface on your server when handling parts.

ESD and handling boards: Always handle boards carefully. They can be extremely sensitive to ESD. Hold boards only by their edges. After removing a board from its protective wrapper or from the server, place the board component side up on a grounded, static free surface. Use a conductive foam pad if available but not the board wrapper. Do not slide board over any surface.

Installing or removing jumpers: A jumper is a small plastic encased conductor that slips over two jumper pins. Some jumpers have a small tab on top that you can grip with your fingertips or with a pair of fine needle nosed pliers. If your jumpers do not have such a tab, take care when using needle nosed pliers to remove or install a jumper; grip the narrow sides of the jumper with the pliers, never the wide sides. Gripping the wide sides can damage the contacts inside the jumper, causing intermittent problems with the function controlled by that jumper. Take care to grip with, but not squeeze, the pliers or other tool you use to remove a jumper, or you may bend or break the pins on the board.

Contents

About this Manual	iii
Manual Organization	iii
Product Accessories	iv
Additional Information and Software	iv
Important Safety Instructions	vii
Wichtige Sicherheitshinweise	vii
Consignes de sécurité	vii
Instrucciones de seguridad importantes	vii
Warnings.....	viii
Server Board Features	1
Connector and Header Locations	4
Configuration Jumpers	5
Back Panel Connectors	6
Hardware Requirements	7
Processor	7
Memory	7
Power Supply	8
Optional Hardware	8
Hard Disk Drives	8
Server Utilities	9
Using the BIOS Setup Utility	9
Starting Setup	9
If You Cannot Access Setup	9
Setup Menus	9
Upgrading the BIOS	11
Preparing for the Upgrade	11
Upgrading the BIOS	12
Clearing the CMOS	12
Hardware Installations and Upgrades	13
Before You Begin	13
Tools and Supplies Needed	13
Installing and Removing Memory	13
Installing DIMMs	14
Removing DIMMs	15
Installing or Replacing the Processor	15
Installing the Processor	15
Installing the Active Heat Sink	18
Installing the Passive Heat Sink	19

Removing a Processor	20
Replacing the Backup Battery	21
Troubleshooting	23
Resetting the System	23
Problems following Initial System Installation	23
Hardware Diagnostic Testing	24
Verifying Proper Operation of Key System Lights	25
Confirming Loading of the Operating System	25
Specific Problems and Corrective Actions	25
Power Light Does Not Light	26
No Characters Appear on Screen	26
Characters Are Distorted or Incorrect	27
System Cooling Fans Do Not Rotate Properly	27
Diskette Drive Activity Light Does Not Light	28
CD-ROM Drive or DVD-ROM Drive Activity Light Does Not Light	28
Cannot Connect to a Server	28
Problems with Network	29
Devices are not Recognized under Device Manager	31
LED Information	31
BIOS POST Beep Codes	32
A Getting Help	33
World Wide Web	33
Telephone	33
B Safety Information	37
English	37
Server Safety Information	37
Safety Warnings and Cautions	37
Intended Application Uses	38
Site Selection	38
Equipment Handling Practices	38
Power and Electrical Warnings	38
System Access Warnings	39
Rack Mount Warnings	40
Electrostatic Discharge (ESD)	40
Other Hazards	41
Sicherheitshinweise für den Server	42
Sicherheitshinweise und Vorsichtsmaßnahmen	42
Zielbenutzer der Anwendung	43
Standortauswahl	43
Handhabung von Geräten	43
Warnhinweise für den Systemzugang	45
Elektrostatische Entladungen (ESD)	46
Andere Gefahren	47
Français	48

Consignes de sécurité sur le serveur	48
Sécurité: avertissements et mises en garde	48
Domaines d'utilisation prévus	49
Sélection d'un emplacement	49
Pratiques de manipulation de l'équipement	49
Décharges électrostatiques†(ESD)	52
Autres risques	53
Información de seguridad del servidor	54
Advertencias y precauciones sobre seguridad	54
Aplicaciones y usos previstos	55
Selección de la ubicación	55
Manipulación del equipo	55
Advertencias el acceso al sistema	57
Descarga electrostática (ESD)	58
C Regulatory and Compliance Information	65
Product Regulatory Compliance	65
Product Safety Compliance	65
Product EMC Compliance - Class A Compliance	65
Certifications / Registrations / Declarations	66
Product Regulatory Compliance Markings	66
Electromagnetic Compatibility Notices	67
FCC (USA)	67
Industry Canada (ICES-003)	68
Europe (CE Declaration of Conformity)	68
Taiwan Declaration of Conformity (BSMI)	68
Korean Compliance (RRL)	69
D Intel® Server Issue Report Form	71

List of Figures

Figure 1. Intel® Server Board SE7230NH1-E.....	1
Figure 2. Server Board Connector and Component Locations	4
Figure 3. DDR vs. DDR2 DIMMs.....	13
Figure 4. Installing DIMMs.....	14
Figure 5. Lift Processor Socket Lever	16
Figure 6. Lift Processor Load Plate	16
Figure 7. Removing Protective Processor Cover	17
Figure 8. Installing the Processor.....	17
Figure 9. Removing the Socket Protective Cover	17
Figure 10. Closing the Load Plate and Socket Lever	18
Figure 11. Installing the Active Heat Sink.....	19
Figure 12. Installing the Passive Heat Sink.....	20
Figure 13. Removing the Battery.....	22

List of Tables

Table 1. Server Board Features	2
Table 2. Configuration Jumpers	5
Table 3. LED Information	6
Table 4. Keyboard Commands.....	10
Table 5. LED Information	31
Table 6. POST Error Beep Codes.....	32
Table 7. Product Certification Markings	66

1 Server Board Features

This chapter briefly describes the main features of the Intel® Server Board SE7230NH1-E. This chapter provides drawings of the product, a list of the server board features, and diagrams showing the location of important components and connections on the server board.

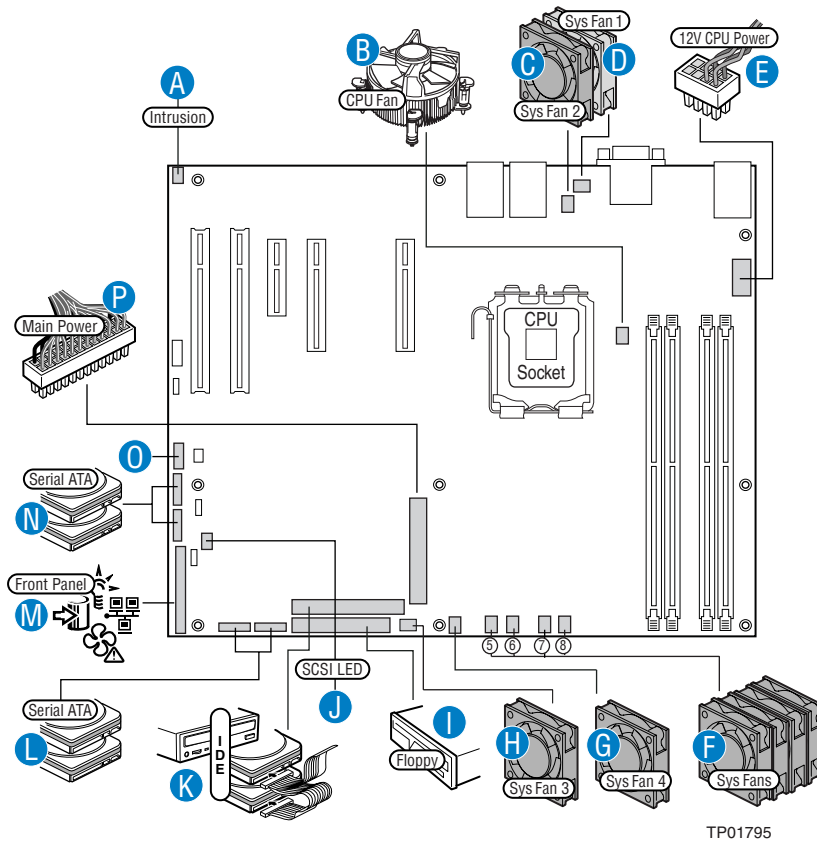

Figure 1. Intel® Server Board SE7230NH1-E

Table 1 summarizes the features of the server board.

Table 1. Server Board Features

Feature	Description
Processor	<ul style="list-style-type: none"> • Support for one Intel® Pentium® D, Pentium® 4 or Celeron® D processor in the LGA775 package • Capable of 1066 MT/s on system bus when using the Intel® Pentium® 4 Processor Extreme Edition supporting Hyper-Threading Technology • Supports Intel® Dual Core Architecture • Supports Intel® Hyper-Threading Technology • Supports Intel® Extended Memory System 64 Technology (EM64T)
Memory	<ul style="list-style-type: none"> • 4 DIMM sockets supporting 400/533/667MHz DDR2 DIMMs • Data bandwidth per channel of 4.2GB/s or 8.4GB/s in dual channel when using DDR2 667MHz • Support for up to two DDR2 channels for a total of 4 DIMMs (2 DIMMs / Channel) providing up to 8GB max memory capacity
Intel® E7230 Chipset Components	<ul style="list-style-type: none"> • Intel® E7230 MCH Memory Controller Hub • Intel® ICH7R I/O controller • Intel® 6702 PXH-V-V PCI-X Hub (LX SKU only) • 12-deep In-Order Queue
I/O Control	<p>LC Super I/O = SMsC* LP47M182NR LX Super I/O = National Semiconductor* PC8374LOIBU</p> <p>External connections:</p> <ul style="list-style-type: none"> • Stacked PS2 Keyboard/Mouse connections • RJ45 Serial B port • Two RJ45 NIC connectors for 10/100/1000 Mb connections • Two USB 2.0 ports <p>Internal connections:</p> <ul style="list-style-type: none"> • One USB port header which supports two USB 2.0 ports • One DH10 Serial A header • Two SATA-150 connectors with integrated RAID 0/1 support • One ATA-100 connector • SSI-compliant 34-pin control panel header
Video	<p>Integrated stand-alone ATI ES1000 graphics engine that supports standard SVGA drivers with analog display capabilities. The graphics subsystem has 16 MB of dedicated memory to support the onboard video controller</p>

Table 1. Server Board Features

Feature	Description
LX Board I/O Subsystem	<p>Five independent PCI Buses:</p> <ul style="list-style-type: none"> • Segment A - Two PCI 32-bit/33-MHz 3.3V Universal connectors supporting full length PCI add-in cards (Adapters which support 5V only are not supported) and one embedded Intel® 10/100/1000 82541PI gigabit Ethernet Controller (Supports PCI Specification, Rev 2.3) • Segment B - One x1 PCI Express resource implemented as a single x4 PCI Express connector supporting x1/x2/x4 PCI Express add-in cards • Segment C - One x1 PCI Express resource implemented as an embedded Intel® 10/100/1000 82573E gigabit Ethernet Controller • Segment D - One x4 PCI Express resource supporting PXH-V-V PCI-X Hub. PXH-V-V supports one dedicated PCI-X 64/100MHz slot and PCI-X portion of the Intel Adaptive Slot • Segment E - One x8 PCI Express resource supporting PCI Express portion of Intel Adaptive Slot. Supports x1/x2/x4/x8 PCI Express add-in cards via riser card
LC Board I/O Subsystem	<p>Five independent PCI Buses:</p> <ul style="list-style-type: none"> • Segment A - Two PCI 32-bit/33-MHz 3.3V Universal connectors supporting full length PCI add-in cards (Adapters which support 5V only are not supported) and one embedded Intel® 10/100/1000 82541PI gigabit Ethernet Controller (Supports PCI Specification, Rev 2.3) • Segment B - One x1 PCI Express resource implemented as a single x4 PCI Express connector supporting x1/x2/x4 PCI Express add-in cards • Segment C - One x1 PCI Express resource implemented as an embedded Intel® 10/100/1000 82573E gigabit Ethernet Controller • Segment D - One x4 PCI Express resource implemented as a single x8 PCI Express connector supporting x1/x2/x4/x8 PCI Express add-in cards • Segment E - One x8 PCI Express resource implemented as a single x8 PCI Express connector supporting x1/x2/x4/x8 PCI Express add-in cards
Hard drive	<ul style="list-style-type: none"> • Ultra ATA100 support: One IDE channel capable of supporting up to two drives. • SATA support: Four independent SATA ports support data transfer rates up to 1.5 Gb/s (150MB/s) per port
Fans	<ul style="list-style-type: none"> • Two general purpose 3-pin fan headers • Two general purpose 4-pin fan headers • One 4-pin processor fan header (active heat sink required) • Four 8-pin dual rotor fan headers for Intel High Density applications (Intel Server Chassis SR1475 and Intel Server Platform SR1475NH1-E)
Other	<p>Intel Light Guided Diagnostic LED's to display POST code indicators during boot (LX version only)</p>

Connector and Header Locations

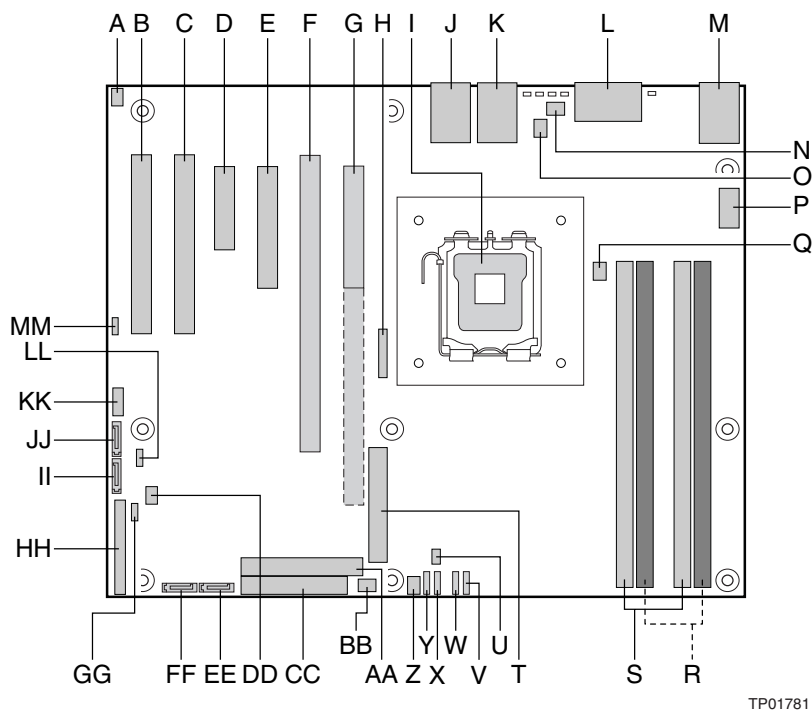

A. Intrusion Header	N. SysFan1	AA.PATA IDE Connector
B. PCI (32bit/33MHz) Slot 1	O. SysFan2	BB.SysFan3
C. PCI (32bit/33MHz) Slot 2	P. 2x4 Processor Power	CC.Floppy Connector
D. PCI Express* x4 (x1 Lane) Slot 3	Q. Processor Fan	DD.SCSI LED Connector
E. PCI Express* x8 (x4 Lane) Slot 4	R. Memory Bank 2	EE.SATA Port 3
F. PCI-X (64bit/100MHz) Slot 5 - LX version only	S. Memory Bank 1	FF.SATA Port 2
G. PCI Express* x8 (x8 Lane) Slot 6 - LC version only; Riser Card Slot - LX version only	T. Main Power	GG.Clear CMOS Jumper
H. Battery	U. Hardware Management Controller	HH.Front Panel Connector
I. Processor Socket	V. SysFan8 - LX version only	II. SATA Port 1
J. NIC1 and USB1-2	W. SysFan7 - LX version only	JJ.SATA Port 0
K. NIC2	X. SysFan6 - LX version only	KK.External USB Connector
L. Serial A and Video Port	Y. SysFan5 - LX version only	LL.CMOS Config Jumper
M. PS2 Stacked Mouse/Keyboard	Z. SysFan4	MM.HSBP Connector

Figure 2. Server Board Connector and Component Locations

Configuration Jumpers

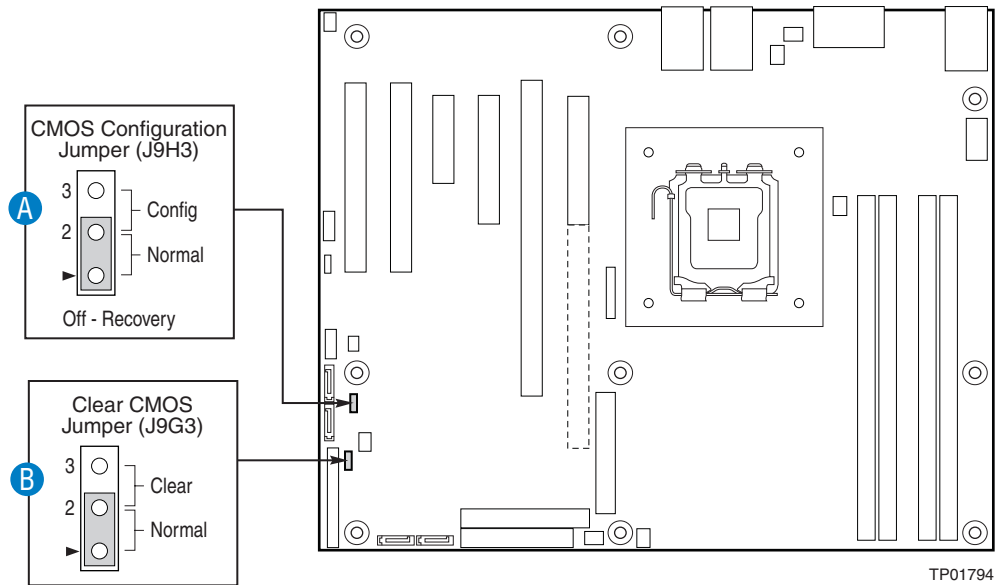
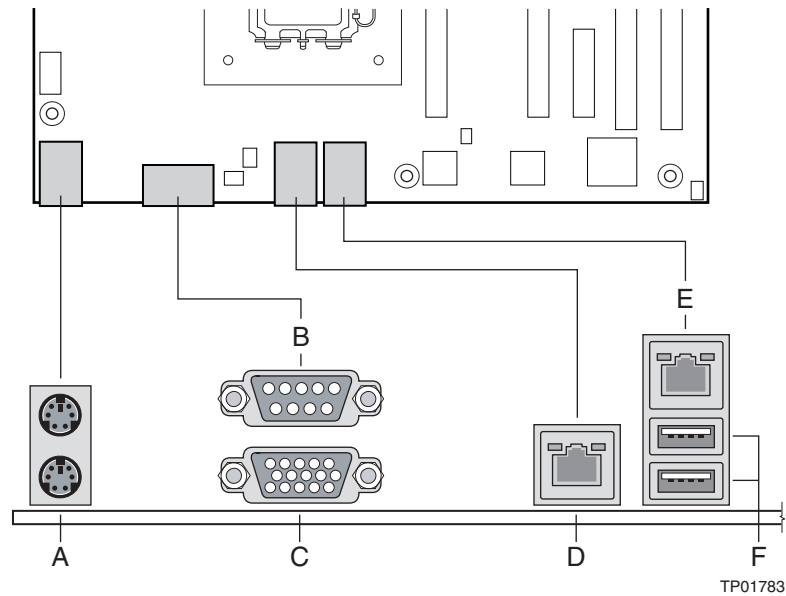

Table 2. Configuration Jumpers

Jumper Name	What happens at system reset...
CMOS Configuration	<p>Pins 1-2 should be jumpered for normal system operation.</p> <p>If pins 2-3 are jumpered, the system will enter a configuration menu that is only available by jumpering these pins. These pins should not be jumpered for normal operation.</p> <p>If the jumper is removed, the system will attempt to recover the BIOS by loading the BIOS code into the flash device from a floppy disk. This is typically used when the BIOS has become corrupted. The jumper should not be removed for normal operation.</p>
Clear CMOS	<p>Pins 1-2 should be jumpered for normal system operation.</p> <p>If pins 2-3 are jumpered, the CMOS settings will be cleared on the next reset. These pins should not be jumpered for normal operation.</p>

Back Panel Connectors



A. Stacked PS2 Mouse/Keyboard Ports

B. Serial A

C. Video

D. NIC2 (10/100/1000Mb)

E. NIC1 (10/100/1000Mb)

F. USB1-2

The NIC LEDs at the right and left of each NIC provide the following information.

Table 3. LED Information

LED	LED State	Description
Left	Off	No network connection
	Solid Amber	Network connection in place
	Blinking Amber	Transmit/receive activity
Right	Off	10 Mbps connection (if left LED is on or blinking)
	Solid Amber	100 Mbps connection
	Solid Green	1000 Mbps connection

Hardware Requirements

To avoid integration difficulties and possible board damage, your system must meet the requirements outlined below. For a list of qualified components, see the links under ["Additional Information and Software."](#)

Processor

One Intel® Pentium® 4 processor, Pentium® D processor, Celeron® D processor, or Pentium® processor Extreme Edition. For a complete list of supported processors, see the links under ["Additional Information and Software."](#)

Memory

The Server Board SE7230NH1-E provides four DIMM sockets across two channels, Channel A and Channel B. Channel A consists of DIMM sockets 1A and 2A. Channel B consists of DIMM sockets 1B and 2B.

A minimum of one 256MB DIMM is required in DIMM socket 1A. This uses single-channel interleave. However, for dual-channel interleave, providing optimum performance, a minimum of two DIMMs should be installed in DIMM sockets 1A and 1B. Except for the option of installing a single DIMM in socket 1A or 1B, DIMMs must be installed in pairs and populated as follows:

- DIMM1A and DIMM 1B: Populate these two sockets together first.
- DIMM 2A and DIMM 2B: Populate these sockets in addition to DIMM 1A and DIMM 1B if four DIMMs are to be used.

DIMMs must meet the following requirements:

- DDR2 400/533/667 , un-buffered, DDR2 DIMM modules
- DIMM organization: x72 ECC or x 64 Non-ECC
- Pin count: 240
- DIMM capacity: 256 MB, 512 MB, 1 GB and 2 GB DIMMs
- Serial PD: JEDEC Rev 2.0
- Serial PD: JEDEC Rev 2.0
- Interface: SSTL2

For a complete list of supported memory DIMMs, see the links under ["Additional Information and Software."](#)

In order to operate in Dual Channel Dynamic Paging Mode, the following conditions must be met:

- Two identical DIMMs are installed, one each in DIMM_1A and DIMM_1B
- Four identical DIMMs are installed (one in each socket location)

Installing only 3 DIMMs is not supported. Do not use DIMMs that are not “matched” (same type and speed). Use of identical memory parts is always the preferred method. See the Intel[®] Server Board SE7230NH1-E *Technical Product Specification* for additional information regarding the memory sub-system.

Power Supply

A minimum of 350 Watts is required. Your supply must provide a minimum of 1.2A of 5V standby current or the board will not boot.

Optional Hardware

Hard Disk Drives

The Server Board SE7230NH1-E supports up to four SATA devices.

See the documentation included with your server chassis for additional drive information and drive installation instructions.

2 Server Utilities

Using the BIOS Setup Utility

This section describes the BIOS Setup Utility options, which is used to change server configuration defaults. You can run BIOS Setup with or without an operating system being present. See [“Additional Information and Software”](#) for a link to the Technical Product Specification where you will find details about specific BIOS setup screens.

Starting Setup

You can enter and start BIOS Setup under several conditions:

- When you turn on the server, after POST completes the memory test
- When you have moved the CMOS jumper on the server board to the “Clear CMOS” position (enabled)

In the two conditions listed above, during the Power On Self Test (POST), you will see this prompt:

```
Press <F2> to enter SETUP
```

In a third condition, when CMOS/NVRAM has been corrupted, you will see other prompts but not the <F2> prompt:

```
Warning: CMOS checksum invalid  
Warning: CMOS time and date not set
```

In this condition, the BIOS will load default values for CMOS and attempt to boot.

If You Cannot Access Setup

If you are not able to access BIOS Setup, you might need to clear the CMOS memory. For instructions on clearing the CMOS, see [“Clearing the CMOS”](#).

Setup Menus

Each BIOS Setup menu page contains a number of features. Except for those features that are provided only to display automatically configured information, each feature is associated with a value field that contains user-selectable parameters. These parameters can be changed if the user has adequate security rights. If a value cannot be changed for any reason, the feature’s value field is inaccessible.

[Table 4](#) describes the keyboard commands you can use in the BIOS Setup menus.

Table 4. Keyboard Commands

Press	Description
<F1>	Help - Pressing F1 on any menu invokes the general Help window.
← →	The left and right arrow keys are used to move between the major menu pages. The keys have no affect if a submenu or pick list is displayed.
↑	Select Item up - The up arrow is used to select the previous value in a menu item's option list, or a value field pick list. Pressing the Enter key activates the selected item.
↓	Select Item down - The down arrow is used to select the next value in a menu item's option list, or a value field pick list. Pressing the Enter key activates the selected item.
F5/-	Change Value - The minus key or the F5 function key is used to change the value of the current item to the previous value. This key scrolls through the values in the associated pick list without displaying the full list.
F6/+	Change Value - The plus key or the F6 function key is used to change the value of the current menu item to the next value. This key scrolls through the values in the associated pick list without displaying the full list. On 106-key Japanese keyboards, the plus key has a different scan code than the plus key on the other keyboard, but it has the same effect.
<Enter>	Execute Command - The Enter key is used to activate submenus when the selected feature is a submenu, or to display a pick list if a selected feature has a value field, or to select a sub-field for multi-valued features like time and date. If a pick list is displayed, the Enter key will undo the pick list, and allow another selection in the parent menu.
<Esc>	Exit - The ESC key provides a mechanism for backing out of any field. This key will undo the pressing of the Enter key. When the ESC key is pressed while editing any field or selecting features of a menu, the parent menu is re-entered. When the ESC key is pressed in any submenu, the parent menu is re-entered. When the ESC key is pressed in any major menu, the exit confirmation window is displayed and the user is asked whether changes can be discarded.
<F9>	<p>Setup Defaults - Pressing F9 causes the following to appear:</p> <p>Setup Confirmation</p> <p>Load default configuration now?</p> <p>[Yes] [No]</p> <p>If "Yes" is selected and the Enter key is pressed, all Setup fields are set to their default values. If "No" is selected and the Enter key is pressed, or if the ESC key is pressed, the user is returned to where they were before F9 was pressed without affecting any existing field values.</p>
<F10>	<p>Save and Exit - Pressing F10 causes the following message to appear:</p> <p>Setup Confirmation</p> <p>Save Configuration changes and exit now?</p> <p>[Yes] [NO]</p> <p>If "Yes" is selected and the Enter key is pressed, all changes are saved and Setup is exited. If "No" is selected and the Enter key is pressed, or the ESC key is pressed, the user is returned to where they were before F10 was pressed without affecting any existing values.</p>

Upgrading the BIOS

The upgrade utility allows you to upgrade the BIOS in flash memory. The code and data in the upgrade file include the following:

- On-board system BIOS, including the recovery code, BIOS Setup Utility, and strings.
- On-board video BIOS, SCSI BIOS, and other option ROMs for devices embedded on the server board.
- OEM binary area
- Microcode
- A way to change the BIOS language

Preparing for the Upgrade

The steps below explain how to prepare to upgrade the BIOS, including how to record the current BIOS settings and how to obtain the upgrade utility.

Note: *In the unlikely event that a BIOS error occurs during the BIOS update process, a recovery process may need to be followed to return the system to service. See “[Additional Information and Software](#)” for a link to necessary software and instructions.*

Recording the Current BIOS Settings

1. Boot the computer and press <F2> when you see the message:
Press <F2> Key if you want to run SETUP
2. Write down the current settings in the BIOS Setup program.

Note: *Do not skip step 2. You will need these settings to configure your computer at the end of the procedure.*

Obtaining the Upgrade

Download the BIOS image file to a temporary folder on your hard drive. See “[Additional Information and Software](#)” for a link to the update software.

Note: *Review the instructions and release notes that are provided in the readme file distributed with the BIOS image file before attempting a BIOS upgrade. The release notes contain critical information regarding jumper settings, specific fixes, or other information to complete the upgrade.*

Upgrading the BIOS

Follow the instructions in the readme file that came with the BIOS upgrade. When the update completes, remove the bootable media from which you performed the upgrade.

Note: Do not power down the system during the BIOS update process! The system will reset automatically when the BIOS update process is completed.

Note: You may encounter a CMOS Checksum error or other problem after reboot. If this happens, shut down the system and boot it again. CMOS checksum errors require that you enter Setup, check your settings, save your settings, and exit Setup.

Clearing the CMOS

If you are not able to access the BIOS setup screens, the CMOS Clear jumper will need to be used to reset the configuration RAM.

1. Power down the system and disconnect the AC power.
2. Open the server and move the jumper from the normal operation position, at pins 1 and 2, to the CMOS Clear position covering pins 2 and 3 as indicated in the following diagram.

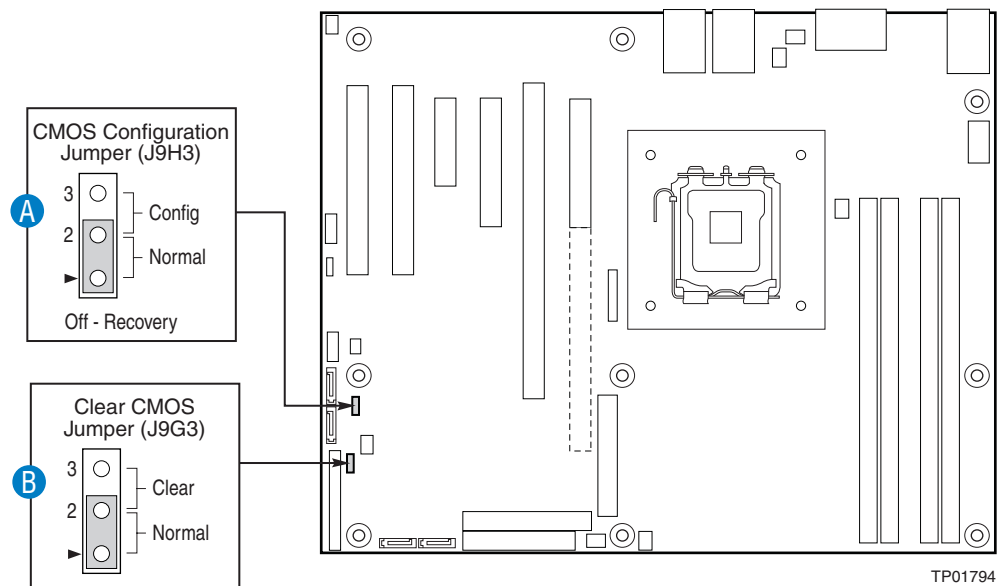

3. Reconnect the AC power, and wait a few seconds. The standby power delivered to the server at this stage will clear the CMOS.
4. Disconnect the AC power and return the CMOS Clear jumper to the Normal location, covering pins 1 and 2.
5. Close the server chassis, reconnect the AC power, and power up the system.

3 Hardware Installations and Upgrades

Before You Begin

Before working with your server product, pay close attention to the “Safety Information” at the beginning of this manual.

Tools and Supplies Needed

- Phillips* (cross head) screwdriver (#1 bit and #2 bit)
- Needle nosed pliers
- Antistatic wrist strap and conductive foam pad (recommended)

Installing and Removing Memory

The silkscreen on the board for the DIMMs displays DIMM_2B, DIMM_1B, DIMM_2A, DIMM_1A starting from the edge of the board. DIMM_1A is the socket closest to the processor socket. See "Memory" for a discussion of the memory requirements and options. See "Additional Information and Software" for a link to the list of tested DIMMs.

Note: The DIMMs being installed must be DDR2 DIMMs (see letter “A” in *Figure 3*). DDR DIMMs will not physically fit into a server board designed to support DDR2 DIMMs (see letter “B” in *Figure 3*).

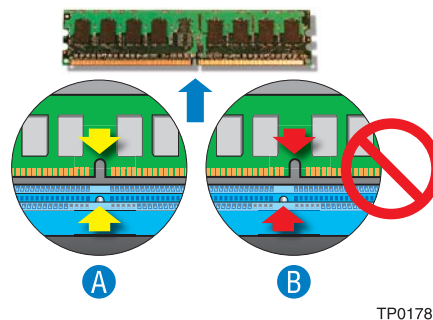

Figure 3. DDR vs. DDR2 DIMMs

Installing DIMMs

To install DIMMs, follow these steps:

1. Observe the safety and ESD precautions in “[Safety Information](#)”.
2. Turn off all peripheral devices connected to the server. Turn off the server.
3. Disconnect the AC power cord from the server.
4. Remove the server's cover. See the documentation that came with your server chassis for instructions on removing the server's cover.
5. Locate the DIMM sockets (see [Figure 4](#)).

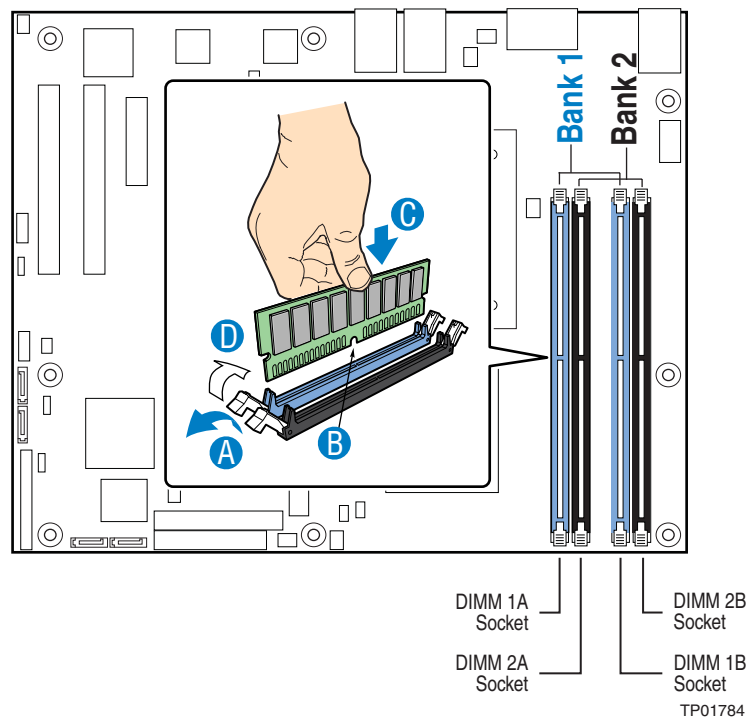

Figure 4. Installing DIMMs

6. Make sure the clips at either end of the DIMM socket(s) are pushed outward to the open position (see letter “A” in [Figure 4](#)).
7. Holding the DIMM by the edges, remove it from its anti-static package.
8. Position the DIMM above the socket. Align the notch on the bottom edge of the DIMM with the key in the DIMM socket (see letter “B” in [Figure 4](#)).
9. Insert the bottom edge of the DIMM into the socket (see letter “C” in [Figure 4](#)).
10. When the DIMM is inserted, push down on the top edge of the DIMM until the retaining clips snap into place. Make sure the clips are firmly in place (see letter “D” in [Figure 4](#)).
11. Replace the server's cover and reconnect the AC power cord. See the documentation that came with your server chassis for instructions on installing the server's cover.

Removing DIMMs

To remove a DIMM, follow these steps:

1. Observe the safety and ESD precautions in [“Safety Information”](#).
2. Turn off all peripheral devices connected to the server. Turn off the server.
3. Remove the AC power cord from the server.
4. Remove the server's cover. See the documentation that came with your server chassis for instructions on removing the server's cover.
5. Gently spread the retaining clips at each end of the socket. The DIMM lifts from the socket.
6. Holding the DIMM by the edges, lift it from the socket, and store it in an anti-static package.
7. Reinstall and reconnect any parts you removed or disconnected to reach the DIMM sockets.
8. Replace the server's cover and reconnect the AC power cord. See the documentation that came with your server chassis for instructions on installing the server's cover.

Installing or Replacing the Processor

Caution: *Processor must be appropriate: You may damage the server board if you install a processor that is inappropriate for your server. See [“Additional Information and Software”](#) for a link to the list of compatible processor(s).*

Caution: *ESD and handling processors: Reduce the risk of electrostatic discharge (ESD) damage to the processor by doing the following: (1) Touch the metal chassis before touching the processor or server board. Keep part of your body in contact with the metal chassis to dissipate the static charge while handling the processor. (2) Avoid moving around unnecessarily.*

Installing the Processor

To install a processor, follow these instructions:

1. Observe the safety and ESD precautions in [“Safety Information”](#).
2. Turn off all peripheral devices connected to the server. Turn off the server.
3. Disconnect the AC power cord from the server.
4. Remove the server's cover. See the documentation that came with your server chassis for instructions on removing the server's cover.

5. Push the lever handle down and away from the socket to release it. Pull the lever and open all the way (see [Figure 5](#)).

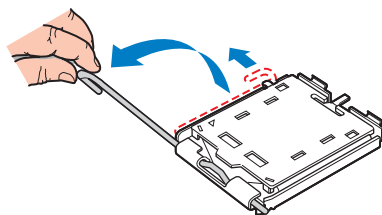

TP01786

Figure 5. Lift Processor Socket Lever

6. Push the rear tab with your finger tip to bring the front end of the load plate up slightly (see letter “A” in [Figure 6](#)). Open the load plate as shown (see letter “B” in [Figure 6](#)). Do not touch the processor socket contacts (see [Figure 6](#)).

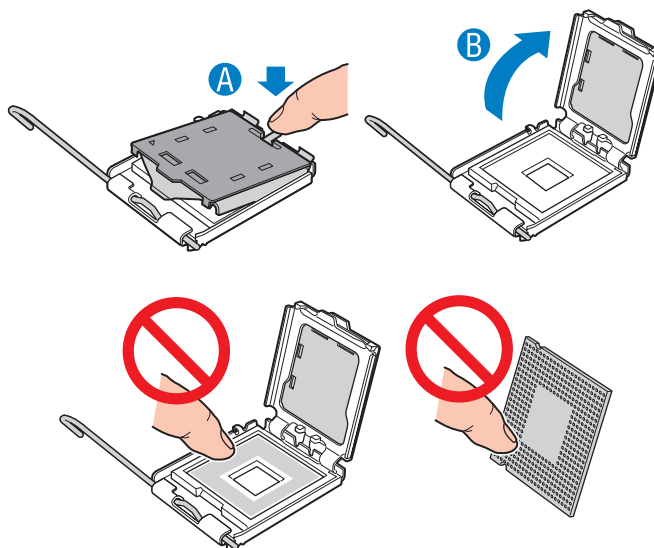

TP01787

Figure 6. Lift Processor Load Plate

7. Take the processor out of the box and remove the protective shipping cover (see [Figure 7](#)).

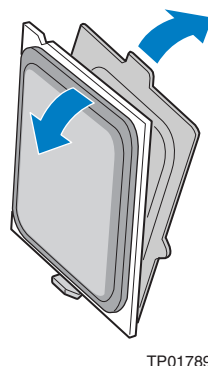

Figure 7. Removing Protective Processor Cover

8. Orient the processor with the socket so that the processor cutout matches the socket notch (see letter “A” in [Figure 8](#)), and insert the processor into the socket (see letter “B” in [Figure 8](#)).

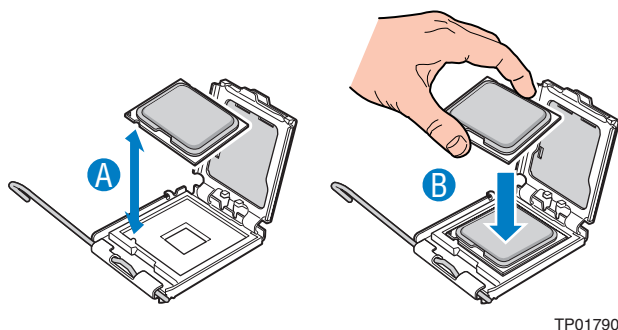

Figure 8. Installing the Processor

9. Grasp the socket protective cover tab and pull away from the load plate (see letter “A” in [Figure 9](#)). Remove the socket protective cover and store for future use (see letter “B” in [Figure 9](#)).

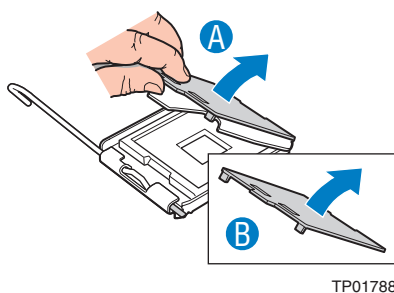

Figure 9. Removing the Socket Protective Cover

10. Close the load plate all the way (see letter “A” in [Figure 10](#)). With your finger, push down on the load plate as shown (see letter “B” in [Figure 10](#)). Close the socket lever and ensure that the load plate tab engages under the socket lever when fully closed (see letter “C” in [Figure 10](#)).

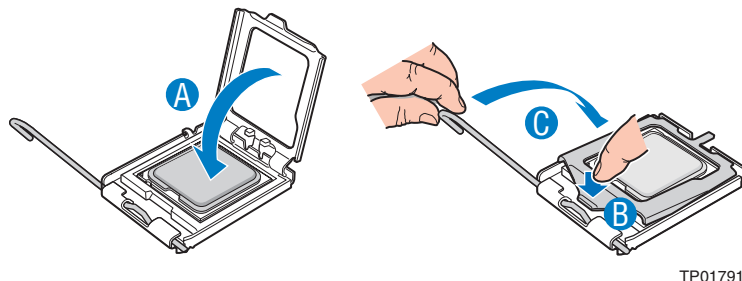

Figure 10. Closing the Load Plate and Socket Lever

Installing the Active Heat Sink

The heat sink has Thermal Interface Material (TIM) located on the bottom of it. Use caution when you unpack the heat sink so you do not damage the TIM.

1. Make sure the screwdriver slot at the top of each fastener is rotated clockwise so the screwdriver slot points to the center of the heat sink as shown (see letter “A” in [Figure 11](#)).
2. Align the heat sink with the mounting holes in the server board and lower the assembly to the board (see letter “B” in [Figure 11](#)). The snaps go through the holes in the server board.
3. Press downward on top of each cap (see letter “C” in [Figure 11](#)).

4. Ensure that the fasteners have snapped into final position (see letter “D” in [Figure 11](#)).

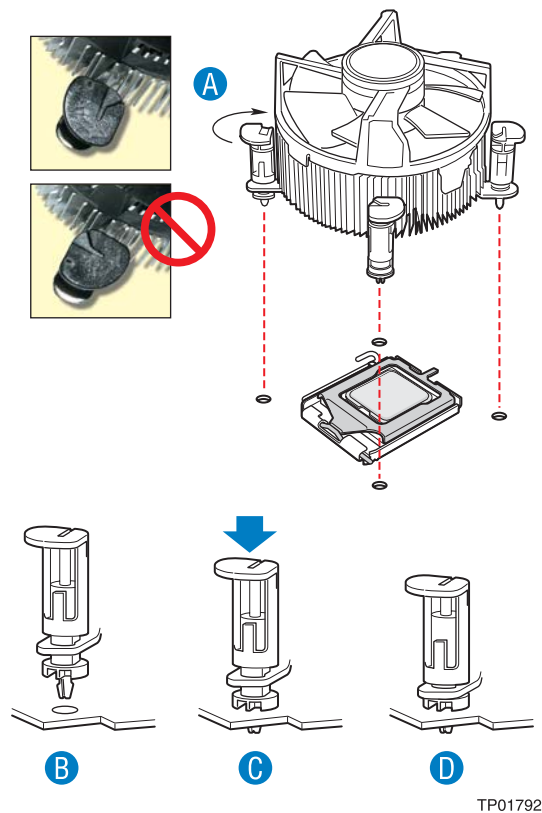

Figure 11. Installing the Active Heat Sink

5. Reinstall and reconnect any parts you removed or disconnected to reach the processor sockets.
6. Replace the server's cover and reconnect the AC power cord. See the documentation that came with your server chassis for instructions on installing the server's cover.

Installing the Passive Heat Sink

If your server board is installed into the Intel Server Platform SR1475NH1-E, a custom copper 1U passive heat sink is installed. The heat sink must be installed with the solid copper sides of it facing to the left and to the right of the chassis. This is necessary because the air from the fans at the front of the chassis must be able to flow from front to back between the copper plates on the other sides of the heat sink.

The heat sink has Thermal Interface Material (TIM) located on the bottom of it. Use caution when you unpack the heat sink so you do not damage the TIM.

1. Set the heat sink over the processor, lining up the four captive screws with the four mounting holes surrounding the processor (see [Figure 12](#)).
2. Loosely screw in the captive screws on the heat sink corners in a diagonal manner. Do not fully tighten one screw before tightening another (see [Figure 12](#) for reference).

3. Gradually and equally tighten each captive screw until each is firmly tightened.

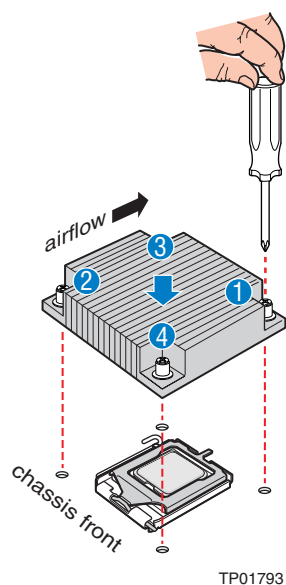

Figure 12. Installing the Passive Heat Sink

4. Reinstall and reconnect any parts you removed or disconnected to reach the processor sockets.
5. Replace the server's cover and reconnect the AC power cord. See the documentation that came with your server chassis for instructions on installing the server's cover.

Removing a Processor

1. Observe the safety and ESD precautions in “[Safety Information](#)”.
2. Turn off all peripheral devices connected to the server. Turn off the server.
3. Remove the AC power cord from the server.
4. Remove the server's cover. See the documentation that came with your server chassis for instructions on removing the server's cover.
5. Unplug the processor fan cable from the server board.
6. Loosen the four captive screws on the corners of the heat sink.
7. Twist the heat sink slightly to break the seal between the heat sink and the processor.
8. Lift the heat sink from the processor. If it does not pull up easily, twist the heat sink again. Do not force the heat sink from the processor. Doing so could damage the processor.
9. Lift the processor lever.
10. Press the release button and lift the load plate.
11. Remove the processor.

12. If installing a replacement processor, see “[Installing the Processor](#)”. Otherwise, close the load plate and lower the socket lever completely.
13. Reinstall the chassis cover.

Replacing the Backup Battery

The lithium battery on the server board powers the RTC for up to 10 years in the absence of power. When the battery starts to weaken, it loses voltage, and the server settings stored in CMOS RAM in the RTC (for example, the date and time) may be wrong. Contact your customer service representative or dealer for a list of approved devices.

Warning: *Danger of explosion if battery is incorrectly replaced. Replace only with the same or equivalent type recommended by the equipment manufacturer. Discard used batteries according to manufacturer's instructions.*

Advarsel: Lithiumbatteri - Eksplosionsfare ved fejlagtig håndtering. Udskiftning må kun ske med batteri af samme fabrikat og type. Levér det brugte batteri tilbage til leverandøren.

Advarsel: Lithiumbatteri - Eksplosjonsfare. Ved utskifting benyttes kun batteri som anbefalt av apparatfabrikanten. Brukt batteri returneres apparatleverandøren.

Warning: Explosionsfara vid felaktigt batteribyte. Använd samma batterityp eller en ekvivalent typ som rekommenderas av apparattillverkaren. Kassera använt batteri enligt fabrikantens instruktion.

Varoitus: Paristo voi räjähtää, jos se on virheellisesti asennettu. Vaihda paristo ainoastaan laitevalmistajan suosittelemaan tyyppiin. Hävitä käytetty paristo valmistajan ohjeiden mukaisesti.

1. Observe the safety and ESD precautions in [“Safety Information”](#).
2. Turn off all peripheral devices connected to the server. Turn off the server.
3. Disconnect the AC power cord from the server.
4. Remove the server's cover and locate the battery. See the documentation that came with your server chassis for instructions on removing the server's cover.
5. Lift the battery retention mechanism (see [Figure 13](#)).
6. Remove the battery from its socket.

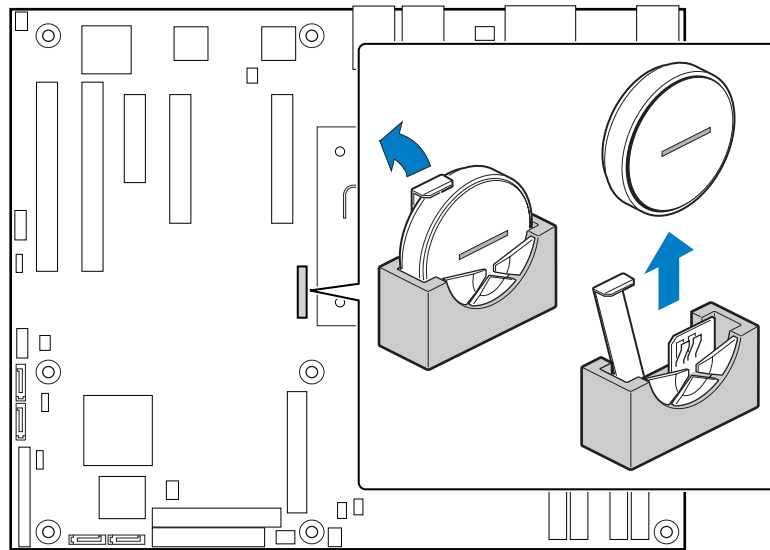

TP01782

Figure 13. Removing the Battery

7. Dispose of the battery according to local ordinance.
8. Remove the new lithium battery from its package, and, being careful to observe the correct polarity, insert it in the battery socket.
9. Close the chassis.
10. Run Setup to restore the configuration settings to the RTC.

4 Troubleshooting

This chapter helps you identify and solve problems that might occur while you are using the system.

For any issue, first ensure you are using the latest firmware and files. Firmware upgrades include updates for BIOS, the baseboard management controller (BMC), and the hot-swap controller (HSC). See [“Additional Information and Software”](#) for a link to the software updates. In addition to the server firmware and files, also update any drivers used for components you have installed in your system, such as video drivers, network drivers, and SCSI drivers.

Intel provides a package called the “Platform Confidence Test” that may help with your diagnostics. See [“Additional Information and Software”](#) for a link to this software.

If you are unable to resolve your server problems on your own, see [“Getting Help”](#) for assistance.

Resetting the System

Before going through in-depth troubleshooting, attempt first to perform reset your system using one of the methods below.

To do this:	Press:
Soft boot reset to clear the system memory and reload the operating system.	<Ctrl+Alt+Del>
Clear system memory, restart POST, and reload the operating system.	Reset button
Cold boot reset. Turn the system power off and then on. This clears system memory, restarts POST, reloads the operating system, and halts power to all peripherals.	Power off/on

Problems following Initial System Installation

Problems that occur at initial system startup are usually caused by an incorrect installation or configuration. Hardware failure is a less frequent cause. If the problem you are experiencing is with a specific software application, see [“Problems with Newly Installed Application Software”](#).

First Steps Checklist

1. Is AC power available at the wall outlet?
2. Are the power supplies plugged in? Check the AC cable(s) on the back of the chassis and at the AC source.

3. Are all cables correctly connected and secured?
4. Are the processors fully seated in their sockets on the server board?
5. Are all standoffs in the proper location and not touching any components, causing a potential short?
6. Are all add-in PCI boards fully seated in their slots on the server board?
7. Are all jumper settings on the server board correct?
8. Are all jumper and switch settings on add-in boards and peripheral devices correct? To check these settings, refer to the manufacturer's documentation that comes with them. If applicable, ensure that there are no conflicts—for example, two add-in boards sharing the same interrupt.
9. Are all peripheral devices installed correctly?
10. If the system has a hard disk drive, is it properly formatted or configured?
11. Are all device drivers properly installed?
12. Are the configuration settings made in Setup correct?
13. Is the operating system properly loaded? Refer to the operating system documentation.
14. Did you press the system power on/off switch on the front panel to turn the server on (power on light should be lit)?
15. Is the system power cord properly connected to the system and plugged into a NEMA 5-15R outlet for 100-120 V~ or a NEMA 6-15R outlet for 200-240 V~?
16. Are all integrated components from the tested components lists? Check the tested memory, and chassis lists, as well as the supported hardware and operating system list. See [“Additional Information and Software”](#) for links to the tested component lists.

Hardware Diagnostic Testing

This section provides a more detailed approach to identifying a hardware problem and locating its source.

Caution: *Turn off devices before disconnecting cables:* Before disconnecting any peripheral cables from the system, turn off the system and any external peripheral devices. Failure to do so can cause permanent damage to the system and/or the peripheral devices.

1. Turn off the system and all external peripheral devices. Disconnect each device from the system, except for the keyboard and the video monitor.
2. Make sure the system power cord is plugged into a properly grounded AC outlet.
3. Make sure your video display monitor and keyboard are correctly connected to the system. Turn on the video monitor. Set its brightness and contrast controls to at least two thirds of their maximum ranges (see the documentation supplied with your video display monitor).

4. If the operating system normally loads from the hard disk drive, make sure there is no diskette in drive A and no CD-ROM disk in the CD-ROM drive.
5. If the power LED does light, attempt to boot from a floppy diskette or from a CD-ROM disk.
6. Turn on the system. If the power LED does not light, see [“Power Light Does Not Light”](#).

Verifying Proper Operation of Key System Lights

As POST determines the system configuration, it tests for the presence of each mass storage device installed in the system. As each device is checked, its activity light should turn on briefly. Check for the following:

1. Does the diskette drive activity light turn on briefly? If not, see [“Diskette Drive Activity Light Does Not Light”](#).
2. If system LEDs are illuminated, see [“LED Information”](#) for a description of the light and steps to take to correct the problem.

Confirming Loading of the Operating System

Once the system boots up, the operating system prompt appears on the screen. The prompt varies according to the operating system. If the operating system prompt does not appear, see [“No Characters Appear on Screen”](#).

Specific Problems and Corrective Actions

This section provides possible solutions for these specific problems:

1. Power light does not light.
2. No characters appear on screen.
3. Characters on the screen appear distorted or incorrect.
4. System cooling fans do not rotate.
5. Diskette drive activity light does not light.
6. Hard disk drive activity light does not light.
7. CD-ROM drive activity light does not light.
8. There are problems with application software.
9. The bootable CD-ROM is not detected.

Try the solutions below in the order given. If you cannot correct the problem, contact your service representative or authorized dealer for help.

Power Light Does Not Light

Check the following:

1. Did you press the power-on button?
2. Is the system operating normally? If so, the power LED might be defective or the cable from the front panel to the server board might be loose.
3. Have you securely plugged the server AC power cord into the power supply?
4. Is the power supply correctly set to 110 V or 235 V, depending on your power output?
5. Will other items plugged into the same power outlet function correctly?
6. Some ATX power supplies have a power switch on the back of the power supply, next to the fan. If your system has one, is it turned on?
7. Remove all add-in cards and see if the system boots. If successful, add the cards back in one at a time with a reboot between each addition.
8. Make sure the memory DIMMs comply with the system requirements.
9. Make sure the memory DIMMs have been populated according to the system requirements.
10. Remove the memory DIMMs and re-seat them.
11. Make sure the processor(s) comply with the system requirements.
12. Make sure the processor(s) have been populated according to the system requirements.
13. Remove the processor(s) and re-seat them.
14. Make sure the chassis standoffs are installed only below mounting holes. Misplaced standoffs can contact the pins on the bottom of the server board and cause a short.

No Characters Appear on Screen

1. Check the following:
2. Is the keyboard functioning? Test it by turning the “Num Lock” function on and off to make sure the Num Lock light is functioning.
3. Is the video monitor plugged in and turned on? If you are using a switch box, is it switched to the correct system?
4. Are the brightness and contrast controls on the video monitor properly adjusted?
5. Is the video monitor signal cable properly installed?
6. Does this video monitor work correctly if plugged into a different system?
7. Is the onboard video controller enabled in the BIOS?
8. Remove all add-in cards and see if the video returns. If successful, add the cards back in one at a time with a reboot between each addition.
9. Make sure the memory DIMMs comply with the system requirements.

10. Make sure the memory DIMMs have been populated according to the system requirements.
11. Remove the memory DIMMs and re-seat them.
12. Make sure the processor(s) comply with the system requirements.
13. Make sure the processor(s) have been populated according to the system requirements.
14. Remove the processor(s) and re-seat them.

If you are using an add-in video controller board, do the following:

- Verify that the video works using the onboard video controller.
- Verify that the video controller board is fully seated in the server board connector.
- Reboot the system for changes to take effect.
- If there are still no characters on the screen after you reboot the system and POST emits a beep code, write down the beep code you hear. This information is useful for your service representative.
- If you do not receive a beep code and characters do not appear, the video display monitor or video controller may have failed. Contact your service representative or authorized dealer for help.

Characters Are Distorted or Incorrect

Check the following:

1. Are the brightness and contrast controls properly adjusted on the video monitor? See the manufacturer's documentation.
2. Are the video monitor's signal and power cables properly installed?
3. Does this video monitor work correctly if plugged into a different system?

System Cooling Fans Do Not Rotate Properly

If the system cooling fans are not operating properly, it is an indication of possible system component failure.

Check the following:

1. Is the power-on light lit? If not, see "Power Light Does Not Light"
2. If your system has LED lights for the fans, is one or more of these LEDs lit?
3. Are any other front panel LEDs lit?
4. Have any of the fan motors stopped? Use the server management subsystem to check the fan status.
5. Have your fans speeded up in response to an overheating situation?

6. Have your fans speeded up in response to a fan that has failed?
7. Are the fan power connectors properly connected to the server board?
8. Is the cable from the front panel board connected to the both the front panel board and to the server board?
9. Are the power supply cables properly connected to the server board?
10. Are there any shorted wires caused by pinched-cables or have power connector plugs been forced into power connector sockets the wrong way?

Diskette Drive Activity Light Does Not Light

Check the following:

1. Are the diskette drive's power and signal cables properly installed?
2. Are all relevant switches and jumpers on the diskette drive set correctly?
3. Is the diskette drive properly configured?
4. Is the diskette drive activity light always on? If so, the signal cable may be plugged in incorrectly.

If you are using the onboard diskette controller, use the BIOS setup to make sure that "Onboard Floppy" is set to "Enabled." If you are using an add-in diskette controller, make sure that "Onboard Floppy" is set to "Disabled."

CD-ROM Drive or DVD-ROM Drive Activity Light Does Not Light

Check the following:

1. Are the CD-ROM/DVD-ROM drive's power and signal cables properly installed?
2. Are all relevant switches and jumpers on the drive set correctly?
3. Is the drive properly configured?

Cannot Connect to a Server

1. Make sure the network cable is securely attached to the correct connector at the system back panel.
2. Try a different network cable.
3. Make sure you are using the correct and the current drivers. See "[Additional Information and Software](#)" for a link to the current drivers.
4. Make sure the driver is loaded and the protocols are bound.
5. Make sure the hub port is configured for the same duplex mode as the network controller.
6. Make sure the correct networking software is installed.
7. If you are directly connecting two servers (without a hub), you will need a crossover cable.

8. Check the network controller LEDs next to the NIC connectors.

Problems with Network

The server hangs when the drivers are loaded.

Certain drivers may require interrupts that are not shared with other PCI drivers. For these drivers, it may be necessary to alter settings so that interrupts are not shared. See the documentation that came with your PCI card(s) for information on changing interrupts.

Diagnostics pass but the connection fails.

1. Make sure the network cable is securely attached.
2. Make sure you specify the correct frame type in your NET.CFG file.

The controller stopped working when an add-in adapter was installed.

1. Make sure the cable is connected to the port from the onboard network controller.
2. Make sure your BIOS is current. See [“Additional Information and Software”](#) for a link to the current version.
3. Make sure the other adapter supports shared interrupts. Make sure your operating system supports shared interrupts.
4. Try re-seating the add-in adapter.

The add-in adapter stopped working without apparent cause.

1. Try re-seating the adapter first; then try a different slot if necessary.
2. The network driver files may be corrupt or deleted. Delete and then reinstall the drivers.
3. Run the diagnostics.

System Boots when Installing PCI Card

System Server Management features require full-time “standby” power. This means some parts of the system have power going to them whenever the power cord is plugged in, even if you have turned the system power off with the power button on the front panel. If you install a PCI card with the AC power cord plugged in, a signal may be sent to the command the system to boot. Before installing a PCI card, you should always:

1. Turn off the server power by using the power button on the front of the system.
2. Unplug the AC power cord(s) from the server.

Problems with Newly Installed Application Software

Problems that occur when you run new application software are usually related to the software, not the server hardware. Faulty equipment is unlikely, especially if other software runs correctly.

Check the following:

1. Make sure the system meets the minimum hardware requirements for the software. See the software documentation.
2. Make sure the software is properly installed and configured for the system. See the software documentation.
3. Use only an authorized copy. Unauthorized copies often do not work.
4. If you are running the software from a diskette, CD-ROM or DVD-ROM, try a different diskette.
5. Make sure the correct device drivers installed.

If the problems persist, contact the software vendor's customer service representative.

Problems with Application Software that Ran Correctly Earlier

Problems that occur after the system hardware and software have been running correctly sometimes indicate equipment failure. However, they can also be caused by file corruption or changes to the software configuration.

Check the following:

1. If you are running the software from a diskette, CD-ROM or DVD-ROM, try a different diskette.
2. Uninstall and reinstall the software. Make sure all necessary files are installed.
3. If the problems are intermittent, there may be a loose cable, dirt in the keyboard (if keyboard input is incorrect), a marginal power supply, or other random component failures.
4. If you suspect that a transient voltage spike, power outage, or brownout might have occurred, reload the software and try running it again. Symptoms of voltage spikes include a flickering video display, unexpected system reboots, and the system not responding to user commands.

Note: *Random errors in data files:* If you are getting random errors in your data files, they may be getting corrupted by voltage spikes on your power line. If you are experiencing any of the above symptoms that might indicate voltage spikes on the power line, you may want to install a surge suppressor between the power outlet and the system power cord.

Devices are not Recognized under Device Manager

The Windows* operating systems do not include all of the drivers for the Intel chipsets, onboard NICs, and other components. See [“Additional Information and Software”](#) for a link to the current drivers and chipset files.

Hard Drive(s) are not Recognized

Check the following:

1. Make sure the drive is not disabled in BIOS Setup.
2. Make sure the drive is connected correctly and that is plugged into the power supply.
3. Make sure the drive is compatible. See [“Additional Information and Software”](#) for a link to the tested drives.
4. Make sure you have not exceeded the power budget for the server. See [“Additional Information and Software”](#) for a link to software to check your power budget.
5. If using SCSI drives, verify that each SCSI ID number is unique on the SCSI bus. See your drive documentation for details on setting the SCSI ID for your drives.
6. If using IDE drives, verify that the master/slave settings are set correctly. See your drive documentation for details on setting the master/slave settings.
7. If using a RAID configuration with SCSI or SATA drives, make sure the RAID card is installed correctly.

Bootable CD-ROM Is Not Detected

Check the following:

- Make sure the BIOS is configured to allow the CD-ROM to be the first bootable device.

LED Information

The Intel® Server Board SE7230NH1-E includes LEDs that can aid in troubleshooting your system. A table of these LEDs with a description of their use is listed below.

Table 5. LED Information

LED Name	Function	Location	LED Color	Notes
Power	Indicates system power is on or off	Front control panel	Green	Off = Power is off or in sleep state S5 On = Power is on or in sleep state S0
ID	Aid in server identification from the back panel	Front control panel and board rear left corner	Blue	Press ID LED button or use Server Management software to turn the LED on and off.

Table 5. LED Information

LED Name	Function	Location	LED Color	Notes
System Fault	Visible fault warning	Control panel and board rear left corner	Green or Amber	Green = No Fault Green blinking = degraded condition Amber blinking = non-critical error Amber = critical or non-recoverable error
Drive Activity				

BIOS POST Beep Codes

The table below lists the POST error beep codes. Prior to system video initialization, the BIOS uses these beep codes to inform users of error conditions. Please note that not all error conditions are supported by BIOS beep codes.

Table 6. POST Error Beep Codes

Number of Beeps	Reason for Beeps and Action to Take
1, 2, or 3	Memory error. Re-seat the memory or replace the DIMMs with known good modules.
4 - 7 or 9 - 11	Fatal error indicating a possible serious system problem. Remove all add-in cards and re-start the system. If the error still occurs, contact your system manufacturer. If the beep codes are not generated after the add-in cards are removed, insert the cards one at a time, booting the system between each card addition, until the beeps again occur to reveal the malfunctioning card.
8	Replace or re-seat the system video add-in card. If on-board video is being used, the server board may be faulty.

A Getting Help

World Wide Web

<http://support.intel.com/support/motherboards/server/SE7230NH1-E>.

Telephone

All calls are billed per incident, levied in local currency at the applicable credit card exchange rate plus applicable taxes. (Intel reserves the right to change the pricing for telephone support at any time without notice).

Before calling, fill out an “[Intel® Server Issue Report Form](#)”. A sample form is provided on the following pages. However, for the fastest service, please submit your form via the Internet.

For an updated support contact list, see <http://www.intel.com/support/9089.htm/>

U.S. and Canada

916-377-7000

Europe

UK..... 870 6072439
France..... 01 41 918529
Germany..... 069 9509 6099
Italy 02 696 33276
Spain..... 91 377 8166
Belgium..... 02 714 3182
Finland 9 693 79297
Denmark..... 38 487077
Norway..... 23 1620 50
Sweden..... 08 445 1251
Holland..... 020 487 4562

In Asia-Pacific region

Australia..... 1800 649931
Hong Kong. 852 2 844 4456
Korea..... 822 767 2595
China 800 820 1100 (toll-free)
..... 8 621 33104691 (not toll-free)
Singapore ... 65 6213-1311
India 0006517 2 68303634 (manual toll-free. You need an IDD-equipped
telephone)
Taiwan..... 2 2545-1640
Indonesia.... 803 65 7249
Malaysia..... 1 800 80 1390
New Zealand 0800 444 365
Pakistan 632 63684 15 (IDD via Philippines)
Philippines.. 1 800 1 651 0117
Thailand 1 800 631 0003
Vietnam 632 6368416 (IDD via Philippines)
Myanmar 63 2 636 9796 (via Philippines)
Cambodia ... 63 2 636 9797 (via Philippines)

Japan

Domestic 0120 868686
Outside country 81 298 47 0800

Latin America

Brazil..... 001-916 377 0180
Mexico Contact AT&T USA at 001 800 462 628 4240. Once connected, dial 800 843
4481
Colombia.... Contact AT&T USA at 01 800 911 0010. Once connected, dial 800 843 4481
Costa Rica.. Contact AT&T USA at 0 800 0 114 114. Once connected, dial 800 843 4481
Panama Contact AT&T USA at 00 800 001 0109. Once connected, dial 800 843 4481

Chile (Easter Island) Contact AT&T USA at 800 800 311. Once connected, dial
800 843 4481

Chile (Mainland and Juan)Contact AT&T USA at 800 225 288. Once connected, dial 800
843 4481

Miami 1 800 621 8423

Ecuador (Andimate) Contact AT&T USA at 1 999 119. Once connected, dial 800
843 4481

Ecuador (Pacifictel) Contact AT&T USA at 1 800 225 528. Once connected, dial
800 843 4481

Guatemala .. Contact AT&T USA at 99 99 190. Once connected, dial 800 843 4481

Venezuela ... Contact AT&T USA at 0 800 2255 288. Once connected, dial 800 843 4481

Argentina.... Contact AT&T USA at 0-800 222 1288. Once connected, dial 800 843 4481

Paraguay 001 916 377 0114

Peru 001 916 377 0114

Uruguay..... 001 916 377 0114

B Safety Information

English

Server Safety Information

This document applies to Intel® server boards, Intel® server chassis (pedestal and rack-mount) and installed peripherals. To reduce the risk of bodily injury, electrical shock, fire, and equipment damage, read this document and observe all warnings and precautions in this guide before installing or maintaining your Intel® server product.







In the event of a conflict between the information in this document and information provided with the product or on the website for a particular product, the product documentation takes precedence.

Your server should be integrated and serviced only by technically qualified persons.

You must adhere to the guidelines in this guide and the assembly instructions in your server manuals to ensure and maintain compliance with existing product certifications and approvals. Use only the described, regulated components specified in this guide. Use of other products / components will void the UL Listing and other regulatory approvals of the product, and may result in noncompliance with product regulations in the region(s) in which the product is sold.

Safety Warnings and Cautions

To avoid personal injury or property damage, before you begin installing the product, read, observe, and adhere to all of the following safety instructions and information. The following safety symbols may be used throughout the documentation and may be marked on the product and / or the product packaging.

CAUTION	Indicates the presence of a hazard that may cause minor personal injury or property damage if the CAUTION is ignored.
WARNING	Indicates the presence of a hazard that may result in serious personal injury if the WARNING is ignored.
	Indicates potential hazard if indicated information is ignored.
	Indicates shock hazards that result in serious injury or death if safety instructions are not followed.
	Indicates hot components or surfaces.
	Indicates do not touch fan blades, may result in injury.
	Indicates to unplug all AC power cord(s) to disconnect AC power
	Please recycle battery

Intended Application Uses

This product was evaluated as Information Technology Equipment (ITE), which may be installed in offices, schools, computer rooms, and similar commercial type locations. The suitability of this product for other product categories and environments (such as medical, industrial, residential, alarm systems, and test equipment), other than an ITE application, may require further evaluation.

Site Selection

The system is designed to operate in a typical office environment. Choose a site that is:

- Clean, dry, and free of airborne particles (other than normal room dust).
- Well-ventilated and away from sources of heat including direct sunlight and radiators.
- Away from sources of vibration or physical shock.
- Isolated from strong electromagnetic fields produced by electrical devices.
- In regions that are susceptible to electrical storms, we recommend you plug your system into a surge suppresser and disconnect telecommunication lines to your modem during an electrical storm.
- Provided with a properly grounded wall outlet.
- Provided with sufficient space to access the power supply cord(s), because they serve as the product's main power disconnect.

Equipment Handling Practices

Reduce the risk of personal injury or equipment damage:

- Conform to local occupational health and safety requirements when moving and lifting equipment.
- Use mechanical assistance or other suitable assistance when moving and lifting equipment.
- To reduce the weight for easier handling, remove any easily detachable components.

Power and Electrical Warnings

Caution: *The power button, indicated by the stand-by power marking, DOES NOT completely turn off the system AC power, 5V standby power is active whenever the system is plugged in. To remove power from system, you must unplug the AC power cord from the wall outlet. Your system may use more than one AC power cord. Make sure all AC power cords are*

unplugged. Make sure the AC power cord(s) is/are unplugged before you open the chassis, or add or remove any non hot-plug components.

Do not attempt to modify or use an AC power cord if it is not the exact type required. A separate AC cord is required for each system power supply.

Some power supplies in Intel® servers use Neutral Pole Fusing. To avoid risk of shock use caution when working with power supplies that use Neutral Pole Fusing.

The power supply in this product contains no user-serviceable parts. Do not open the power supply. Hazardous voltage, current and energy levels are present inside the power supply. Return to manufacturer for servicing.

When replacing a hot-plug power supply, unplug the power cord to the power supply being replaced before removing it from the server.

To avoid risk of electric shock, turn off the server and disconnect the power cord, telecommunications systems, networks, and modems attached to the server before opening it.

Power Cord Warnings

If an AC power cord was not provided with your product, purchase one that is approved for use in your country.

Caution: *To avoid electrical shock or fire, check the power cord(s) that will be used with the product as follows:*

- *Do not attempt to modify or use the AC power cord(s) if they are not the exact type required to fit into the grounded electrical outlets*
- *The power cord(s) must meet the following criteria:*
- *The power cord must have an electrical rating that is greater than that of the electrical current rating marked on the product.*
- *The power cord must have safety ground pin or contact that is suitable for the electrical outlet.*
- *The power supply cord(s) is/are the main disconnect device to AC power. The socket outlet(s) must be near the equipment and readily accessible for disconnection.*
- *The power supply cord(s) must be plugged into socket-outlet(s) that is /are provided with a suitable earth ground.*

System Access Warnings

Caution: *To avoid personal injury or property damage, the following safety instructions apply whenever accessing the inside of the product:*

- *Turn off all peripheral devices connected to this product.*
- *Turn off the system by pressing the power button to off.*
- *Disconnect the AC power by unplugging all AC power cords from the system or wall outlet.*

- *Disconnect all cables and telecommunication lines that are connected to the system.*
- *Retain all screws or other fasteners when removing access cover(s). Upon completion of accessing inside the product, refasten access cover with original screws or fasteners.*
- *Do not access the inside of the power supply. There are no serviceable parts in the power supply. Return to manufacturer for servicing.*
- *Power down the server and disconnect all power cords before adding or replacing any non hot-plug component.*
- *When replacing a hot-plug power supply, unplug the power cord to the power supply being replaced before removing the power supply from the server.*

Caution: *If the server has been running, any installed processor(s) and heat sink(s) may be hot. Unless you are adding or removing a hot-plug component, allow the system to cool before opening the covers. To avoid the possibility of coming into contact with hot component(s) during a hot-plug installation, be careful when removing or installing the hot-plug component(s).*

Caution: *To avoid injury do not contact moving fan blades. If your system is supplied with a guard over the fan, do not operate the system without the fan guard in place.*

Rack Mount Warnings

The equipment rack must be anchored to an unmovable support to prevent it from tipping when a server or piece of equipment is extended from it. The equipment rack must be installed according to the rack manufacturer's instructions.

Install equipment in the rack from the bottom up, with the heaviest equipment at the bottom of the rack.

Extend only one piece of equipment from the rack at a time.

You are responsible for installing a main power disconnect for the entire rack unit. This main disconnect must be readily accessible, and it must be labeled as controlling power to the entire unit, not just to the server(s).

To avoid risk of potential electric shock, a proper safety ground must be implemented for the rack and each piece of equipment installed in it.

Electrostatic Discharge (ESD)

Caution: *ESD can damage disk drives, boards, and other parts. We recommend that you perform all procedures at an ESD workstation. If one is not available, provide some ESD protection by wearing an antistatic wrist strap attached to chassis ground -- any unpainted metal surface -- on your server when handling parts.*

Always handle boards carefully. They can be extremely sensitive to ESD. Hold boards only by their edges. After removing a board from its protective wrapper or from the

server, place the board component side up on a grounded, static free surface. Use a conductive foam pad if available but not the board wrapper. Do not slide board over any surface.

Other Hazards

Battery Replacement

Caution: *There is the danger of explosion if the battery is incorrectly replaced. When replacing the battery, use only the battery recommended by the equipment manufacturer.*

Dispose of batteries according to local ordinances and regulations.

Do not attempt to recharge a battery.

Do not attempt to disassemble, puncture, or otherwise damage a battery.

Cooling and Airflow

Caution: *Carefully route cables as directed to minimize airflow blockage and cooling problems.*

For proper cooling and airflow, operate the system only with the chassis covers installed. Operating the system without the covers in place can damage system parts. To install the covers:

- *Check first to make sure you have not left loose tools or parts inside the system.*
- *Check that cables, add-in boards, and other components are properly installed.*
- *Attach the covers to the chassis according to the product instructions.*

Laser Peripherals or Devices

Caution: *To avoid risk of radiation exposure and/or personal injury:*

- *Do not open the enclosure of any laser peripheral or device*
- *Laser peripherals or devices have are not user serviceable*
- *Return to manufacturer for servicing*

Deutsch

Sicherheitshinweise für den Server

Das vorliegende Dokument bezieht sich auf Intel® Serverplatinen, Intel® Servergehäuse (Standfuß und Rack) sowie installierte Peripheriegeräte. Es enthält Warnungen und Vorsichtsmaßnahmen zur Vermeidung von Gefahren durch Verletzung, Stromschlag, Feuer und Beschädigungen von Geräten. Lesen Sie diese Dokument daher sorgfältig, bevor Sie Ihr Intel® Serverprodukt installieren oder warten.







Bei Widersprüchen zwischen den hier vorliegenden Angaben und den Informationen im Lieferumfang des Produkts oder auf der Website des betreffenden Produkts hat die Produktdokumentation Vorrang.

Die Integration und Wartung des Servers darf nur durch technisch qualifizierte Personen erfolgen.

Um die Einhaltung der vorhandenen Zulassungen und Genehmigungen für das Produkt zu gewährleisten, sind die Richtlinien in diesem Handbuch sowie die Montageanleitungen in den Serverhandbüchern zu beachten. Verwenden Sie nur die beschriebenen, zugelassenen Komponenten, die im vorliegenden Handbuch angegeben werden. Die Verwendung anderer Produkte oder Komponenten führt zum Erlöschen der UL-Zulassung und anderer Genehmigungen für das Produkt. Dadurch kann das Produkt gegen Produktbestimmungen verstoßen, die im Verkaufsland gelten.

Sicherheitshinweise und Vorsichtsmaßnahmen

Um Verletzungen und Beschädigungen zu vermeiden, sollten Sie vor dem Beginn der Produktinstallation die nachfolgend aufgeführten Sicherheitshinweise und -informationen sorgfältig lesen und befolgen. In dem vorliegenden Handbuch sowie auf dem Produkt und auf der Verpackung werden folgende Sicherheitssymbole verwendet:

VORSICHT	Weist auf eine Gefahrenquelle hin, die bei Nichtbeachtung des VORSICHTSHINWEISES zu leichteren Verletzungen bzw. Sachbeschädigungen führen kann.
WARNUNG	Weist auf eine Gefahrenquelle hin, die bei Nichtbeachtung der WARNUNG zu ernstesten Verletzungen führen kann.
	Weist auf potentielle Gefahr bei Nichtbeachtung der angezeigten Informationen hin.
	Weist auf die Gefahr eines Stromschlags hin, der bei Nichtbeachtung der Sicherheitshinweise zu schweren oder tödlichen Verletzungen führen kann.
	Weist auf Verbrennungsgefahr an heißen Bauteilen bzw. Oberflächen hin.
	Weist darauf hin, daß das Anfassen des Gebläses zu Verletzungen führen kann.
	Bedeutet, alle Netzkabel abzuziehen und das Gerät von der Netzspannung zu trennen.
	Bereiten Sie bitte Batterie auf

Zielbenutzer der Anwendung

Dieses Produkt wurde in seiner Eigenschaft als IT-Gerät getestet, das in Büros, Schulen, Computerräumen und ähnlichen öffentlichen Räumlichkeiten installiert werden kann. Die Eignung dieses Produkts für andere Einsatzbereiche als IT (z. B. Medizin, Industrie, Alarmsysteme oder Prüfgeräte) kann u. U. weitere Tests erfordern.

Standortauswahl

Das System ist für den Betrieb innerhalb normaler Büroumgebungen geeignet. Wählen Sie einen Standort, der folgenden Kriterien entspricht:

- Sauber, trocken und frei von Partikeln in der Luft (außer dem normalen Raumstaub).
- Gut belüftet, nicht in der Nähe von Wärmequellen und keiner direkten Sonnenbestrahlung ausgesetzt.
- Nicht in der Nähe von Vibrations- oder Erschütterungsquellen.
- Abgeschirmt von starken elektromagnetischen Feldern, die durch elektrische Geräte erzeugt werden.
- In gewittergefährdeten Gebieten sollten Sie das System an einen Überspannungsschutz anschließen und bei einem Gewitter die Telekommunikationskabel zum Modem abziehen.
- Eine ordnungsgemäß geerdete Wandsteckdose muß vorhanden sein.
- Ausreichender Freiraum für den Zugang zu den Netzkabeln, da diese die Hauptvorrichtung zum Trennen des Produkts von der Stromversorgung sind.

Handhabung von Geräten

Beachten Sie zur Vermeidung von Verletzungen oder Beschädigungen an den Geräten die folgenden Hinweise:

- Halten Sie beim Transportieren und Anheben von Geräten die örtlichen Gesundheits- und Sicherheitsvorschriften ein.
- Verwenden Sie mechanische oder andere geeignete Hilfsmittel zum Transportieren oder Anheben von Geräten.
- Entfernen Sie alle Komponenten, die sich leicht abnehmen lassen, um das Gewicht zu reduzieren und die Handhabung zu erleichtern.

Warnungen zu Netzspannung und Elektrizität

Vorsicht: Durch Betätigen der mit dem Standby-Symbol gekennzeichneten Netztaste wird das System NICHT vollständig vom Netz getrennt. Es sind weiterhin 5 V aktiv, solange das System eingesteckt ist. Um das System vollständig vom Strom zu trennen, muß das Netzkabel aus der Steckdose abgezogen werden. Das System verfügt möglicherweise über mehrere Netzkabel. Vergewissern Sie sich in diesem Fall, daß alle Netzkabel abgezogen sind. Wenn Sie Komponenten ein- oder ausbauen möchten, die nicht hot-plug-fähig sind, stellen Sie sicher, daß zuvor alle Netzkabel abgezogen sind.

Nehmen Sie keine Änderungen am Netzkabel vor, und verwenden Sie kein Kabel, das nicht genau dem geforderten Typ entspricht. Jedes Netzteil im System muß über ein eigenes Netzkabel angeschlossen werden.

Einige Netzteile von Intel Servern verwenden Nullleitersicherungen. Vorsicht ist geboten im Umgang mit Netzteilen, welche Nullleitersicherungen verwenden, um das Risiko eines elektrischen Schlages zu vermeiden

Das Netzteil in diesem Produkt enthält keine Teile, die vom Benutzer gewartet werden können. Öffnen Sie das Netzteil nicht. Im Netzteil bestehen gefährliche Spannungen, Ströme und Energiequellen. Schicken Sie das Gerät für Wartungsarbeiten an den Hersteller zurück.

Wenn Sie ein hot-plug-fähiges Netzteil austauschen, ziehen Sie dessen Netzkabel ab, bevor Sie es aus dem Server ausbauen.

Zur Vermeidung von Stromschlägen schalten Sie den Server aus, und trennen Sie vor dem Öffnen des Geräts das Netzkabel sowie alle an den Server angeschlossene Telekommunikationssysteme, Netzwerke und Modems.

Hinweis für Netzkabel

Wenn kein Netzkabel mit dem Produkt geliefert wurde, kaufen Sie ein Kabel, das für die

Vorsicht: Prüfen Sie zur Vermeidung von Stromschlag- oder Feuergefahr die mit dem Produkt zu verwendenden Netzkabel wie folgt:

- Nehmen Sie keine Änderungen an einem Netzkabel vor, und benutzen sie es nicht, wenn es nicht genau in die geerdeten Netzsteckdosen paßt.
- Netzkabel müssen die folgenden Anforderungen erfüllen:
- Die Nennbelastbarkeit des Netzkabels muß mindestens so hoch sein wie die am Produkt angegebenen Nennstromaufnahme.
- Das Netzkabel muß einen zur Netzsteckdose passenden Schutzkontakt besitzen.
- Die Netzkabel sind die Hauptvorrichtung zum Trennen des Geräts vom Stromnetz. Die Steckdose muß in der Nähe der Anlage angebracht und gut erreichbar sein.
- Netzkabel müssen an eine ordnungsgemäß geerdete Steckdose angeschlossen sein.

Warnhinweise für den Systemzugang

Vorsicht: Um Verletzungen und Beschädigungen zu vermeiden, sollten Sie vor Arbeiten im Produktinneren folgende Sicherheitsanweisungen beachten:

- Schalten Sie alle am Produkt angeschlossenen Peripheriegeräte aus.
- Schalten Sie das System mit dem Netzschalter aus.
- Trennen Sie das Gerät von der Stromquelle, indem Sie alle Netzkabel vom System bzw. aus der Steckdose ziehen.
- Ziehen Sie alle Kabel und alle an das System angeschlossenen Telekommunikationsleitungen ab.
- Bewahren Sie alle Schrauben und anderen Befestigungselemente gut auf, nachdem Sie die Gehäuseabdeckung entfernt haben. Wenn Sie Ihre Arbeiten im Systeminneren beendet haben, befestigen Sie die Gehäuseabdeckung mit den Originalschrauben bzw. -befestigungselementen.
- Führen Sie keine Arbeiten im Netzteil aus. Das Netzteil enthält keine für den Benutzer wartungsbedürftigen Teile. Schicken Sie das Gerät für Wartungsarbeiten an den Hersteller zurück.
- Schalten Sie den Server aus, und ziehen Sie alle Netzkabel ab, bevor Sie Komponenten ein- oder ausbauen, die nicht hot-plug-fähig sind.
- Wenn Sie ein hot-plug-fähiges Netzteil austauschen, ziehen Sie dessen Netzkabel ab, bevor Sie es aus dem Server ausbauen.

Vorsicht: War Ihr Server in Betrieb, können die installierten Prozessoren und Kühlkörper heiß sein. Sofern Sie keine Hot-Plug-Komponenten ein- oder ausbauen, warten Sie mit dem Abnehmen der Abdeckungen, bis das System abgekühlt ist. Gehen Sie beim Aus- oder Einbauen von Hot-Plug-Komponenten sorgfältig vor, um nicht mit heißen Komponenten in Berührung zu kommen.

Vorsicht: Berühren Sie nicht die rotierenden Lüfterflügel, um Verletzungen zu vermeiden. Falls Ihr System mit einer Lüfterabdeckung besitzt, darf es nicht ohne diese Abdeckung betrieben werden.

Warnhinweise für Racks

Das Geräte-Rack muß auf einer geeigneten, festen Unterlage verankert werden, um ein Umkippen zu vermeiden, wenn ein Server oder andere Geräte herausgezogen werden. Bei der Installation des Racks müssen die Anweisungen des Rack-Herstellers beachtet werden.

Gehen Sie bei der Installation von Geräten im Rack immer von unten nach oben vor, und bauen Sie das schwerste Gerät an der untersten Position im Rack ein.

Ziehen Sie jeweils immer nur ein Gerät aus dem Rack heraus.

Sie müssen für die gesamte Rack-Einheit einen Netztrennschalter einrichten. Dieser Netztrennschalter muß leicht zugänglich sein und über eine Kennzeichnung verfügen, die besagt, daß er die Stromzufuhr zur gesamten Einheit steuert und nicht nur zu den Servern.

Zur Vermeidung von Stromschlaggefahr müssen das Rack selbst und alle darin eingebauten Geräte ordnungsgemäß geerdet sein.

Elektrostatische Entladungen (ESD)

Vorsicht: *Elektrostatische Entladungen können zur Beschädigung von Festplatten, Platinen und anderen Komponenten führen. Daher sollten Sie alle Arbeiten an einer ESD-Workstation ausführen. Steht ein solcher Arbeitsplatz nicht zur Verfügung, erzielen Sie einen gewissen Schutz vor elektrostatischen Entladungen durch Tragen einer Antistatik-Manschette, die Sie während der Arbeit zur Erdung an einem beliebigen unlackierten Metallteil des Computergehäuses befestigen.*

Gehen Sie bei der Handhabung von Platinen immer mit größter Vorsicht vor. Sie können äußerst empfindlich gegenüber elektrostatischer Entladung sein. Halten Sie Platinen nur an den Kanten fest. Legen Sie die Platinen nach dem Auspacken aus der Schutzhülle oder nach dem Ausbau aus dem Server mit der Bauelementseite nach oben auf eine geerdete, statisch entladene Unterlage. Verwenden Sie dazu, sofern verfügbar, eine leitfähige Schaumstoffunterlage, aber nicht die Schutzhülle der Platine. Ziehen Sie die Platine nicht über eine Fläche.

Andere Gefahren

Batterieaustausch

Vorsicht: Wird die Batterie unsachgemäß ausgetauscht, besteht Explosionsgefahr. Verwenden Sie als Ersatz nur die vom Gerätehersteller empfohlene Batterie.

Beachten Sie bei der Entsorgung von Batterien die gültigen Bestimmungen.

Versuchen Sie nicht, eine Batterie aufzuladen.

Versuchen Sie nicht, eine Batterie zu öffnen oder sonstwie zu beschädigen.

Kühlung und Luftstrom

Vorsicht: Verlegen Sie Kabel sorgfältig entsprechend der Anleitung, um Störungen des Luftstroms und Kühlungsprobleme zu vermeiden.

Zur Gewährleistung des ordnungsgemäßen Kühlungs- und Luftstromverhaltens darf das System nur mit angebrachten Gehäuseabdeckungen betrieben werden. Die Inbetriebnahme des Systems ohne Abdeckung kann zur Beschädigung von Systemkomponenten führen. So bringen Sie die Abdeckung wieder an:

- Vergewissern Sie sich zunächst, daß Sie keine Werkzeuge oder Teile im Gehäuse vergessen haben.
- Prüfen Sie, ob Kabel, Erweiterungskarten sowie weitere Komponenten ordnungsgemäß angebracht sind.
- Befestigen Sie die Abdeckungen am Gehäuse des Produkts, wie in dessen Anleitung beschrieben.

Laser-Peripheriegeräte oder -Komponenten

Vorsicht: Beachten Sie zur Vermeidung von Strahlung und Verletzungen die folgenden Hinweise:

- Öffnen Sie keinesfalls das Gehäuse von Laser-Peripheriegeräten oder Laser-Komponenten.
- Laser-Peripheriegeräte oder -Komponenten besitzen keine für den Benutzer wartungsbedürftigen Teile.
- Schicken Sie das Gerät für Wartungsarbeiten an den Hersteller zurück.

Français

Consignes de sécurité sur le serveur

Ce document s'applique aux cartes serveur Intel®, au châssis de serveur Intel® (sur pieds et sur rack) et aux périphériques installés. Pour réduire les risques de dommages corporels, d'électrocution, d'incendie et de dommages matériels, lisez ce document et respectez tous les avertissements et précautions mentionnés dans ce guide avant d'installer ou de mettre à jour votre produit serveur Intel®.







En cas de conflit entre les informations fournies dans ce document et celles livrées avec le produit ou publiées sur le site Web pour un produit particulier, la documentation du produit prime.

Votre serveur doit être intégré et entretenu uniquement par des techniciens qualifiés.

Vous devez suivre les informations de ce guide et les instructions d'assemblage des manuels de serveur pour vérifier et maintenir la conformité avec les certifications et approbations de produit existantes. Utilisez uniquement les composants décrits et réglementés spécifiés dans ce guide. L'utilisation d'autres produits/composants annulera la liste UL et les autres approbations réglementaires du produit, et le produit peut ne pas être conforme aux autres lois et réglementations locales applicables au produit.

Sécurité: avertissements et mises en garde

Pour éviter de vous blesser ou d'endommager votre équipement, lisez et respectez toutes les informations et consignes de sécurité avant de commencer l'installation du produit. Les symboles de sécurité suivants peuvent être utilisés tout au long de cette documentation et peuvent figurer sur le produit ou sur son emballage.

ATTENTION	Indique la présence d'un risque pouvant entraîner des blessures physiques mineures ou endommager légèrement le matériel si la mise en garde n'est pas prise en compte.
AVERTISSEMENT	Indique la présence d'un risque pouvant entraîner des blessures corporelles graves si l'avertissement n'est pas pris en compte.
	Indique un risque potentiel si les informations signalées ne sont pas prises en compte.
	Indique des risques d'électrocution pouvant entraîner des blessures corporelles graves ou mortelles si les consignes de sécurité ne sont pas respectées.
	Signale des composants ou des surfaces soumis à des températures élevées.
	Indique de ne pas toucher aux pales de ventilateur, car cela peut entraîner des blessures.
	Indique de débrancher tous les cordons d'alimentation secteur pour déconnecter l'alimentation.
	Veuillez réutiliser la batterie

Domaines d'utilisation prévus

Ce produit a été testé comme équipement informatique (ITE) et peut être installé dans des bureaux, des écoles, des salles informatiques et des endroits commerciaux similaires. L'utilisation du présent produit dans des catégories et environnements de produits et domaines d'application (par exemple, le domaine médical, industriel, résidentiel, les systèmes d'alarme et les appareils de contrôle) autres qu'ITE doit faire l'objet d'évaluations supplémentaires.

Sélection d'un emplacement

Le système est conçu pour fonctionner dans un environnement standard de bureau. Choisissez un emplacement respectant les conditions suivantes :

- Propre, sec et exempt de particules en suspension (autres que la poussière normale d'une pièce).
- Bien ventilé et à l'écart des sources de chaleur telles que la lumière directe du soleil et les radiateurs.
- À l'écart des sources de vibration ou des chocs physiques.
- Isolé des champs électromagnétiques importants produits par des appareils électriques.
- Dans les régions sujettes aux orages magnétiques, nous vous recommandons de brancher votre système à un suppresseur de surtension et de déconnecter les lignes de télécommunication de votre modem pendant les orages.
- Équipé d'une prise murale reliée à la terre.
- Équipé d'un espace suffisant pour accéder aux cordons d'alimentation secteur, car ils servent de disjoncteur principal d'alimentation du produit.

Pratiques de manipulation de l'équipement

Réduisez le risque de dommages personnels ou matériels :

- Conformez-vous aux exigences de médecine du travail et de sécurité lorsque vous déplacez et soulevez le matériel.
- Utilisez l'assistance mécanique ou toute autre assistance appropriée lorsque vous déplacez et soulevez le matériel.
- Pour réduire le poids en vue de faciliter la manipulation, retirez tout composant amovible.

Alimentation et avertissements en matière d'électricité

Attention: Le bouton d'alimentation, indiqué par le symbole de mise en veille, NE COUPE PAS complètement l'alimentation secteur du système car le courant de veille 5 V reste actif lorsque le système est sous tension. Pour couper l'alimentation du système, vous devez débrancher le cordon d'alimentation secteur de la prise murale. Votre système peut utiliser plusieurs cordons d'alimentation secteur. Assurez-vous que tous les cordons d'alimentation sont débranchés. Vous devez les débrancher avant d'ouvrir le châssis, d'ajouter ou de supprimer un composant non connectable à chaud.

Les alimentations de certains serveurs Intel sont munies de doubles fusibles pôle/neutre: veuillez observer les précautions d'usage afin d'éviter tout risque d'électrocution.

N'essayez pas de modifier ou d'utiliser un cordon d'alimentation secteur s'il ne s'agit pas du type exact requis. Un cordon secteur est requis pour chaque alimentation système.

Le bloc d'alimentation de ce produit ne contient aucun composant réparable par l'utilisateur. N'ouvrez pas le bloc d'alimentation. L'intérieur de celui-ci est soumis à des niveaux dangereux de tension, de courant et d'énergie. Renvoyez-le au fabricant en cas de problème.

Lorsque vous remplacez un bloc d'alimentation à chaud, débranchez le cordon du bloc d'alimentation en cours de remplacement avant de le retirer du serveur.

Pour éviter tout risque d'électrocution, mettez le système hors tension et débranchez les cordons d'alimentation ainsi que les systèmes de télécommunication, réseaux et modems reliés au système avant d'ouvrir ce dernier.

Avertissements sur le cordon d'alimentation

Si aucun cordon d'alimentation secteur n'a été fourni avec votre produit, vous devez vous en procurer un qui soit approuvé pour une utilisation dans votre pays.

Attention: Pour éviter tout risque d'électrocution ou d'incendie, vérifiez les cordons d'alimentation qui seront utilisés avec le produit comme suit:

- N'essayez pas d'utiliser ou de modifier les cordons d'alimentation en CA s'ils ne correspondent pas exactement au type requis pour les prises électriques reliées à la terre.
- Les cordons d'alimentation doivent répondre aux critères suivants :
- Le cordon d'alimentation doit supporter une intensité supérieure à celle indiquée sur le produit.
- Le cordon d'alimentation doit posséder une broche ou un contact de mise à la terre approprié à la prise électrique.
- Les cordons d'alimentation électrique représentent le principal dispositif de déconnexion raccordé à l'alimentation secteur. Les prises de courant doivent se trouver à proximité de l'équipement et être facilement accessibles pour une déconnexion.
- Les cordons d'alimentation doivent être branchés sur des prises électriques correctement reliées à la terre.

Avertissements sur l'accès au système

Attention: Pour éviter de vous blesser ou d'endommager votre équipement, les consignes de sécurité suivantes s'appliquent chaque fois que vous accédez à l'intérieur du produit:

- Mettez hors tension tous les périphériques connectés à ce produit.
- Éteignez le système en appuyant sur le bouton d'alimentation.
- Déconnectez l'alimentation secteur en débranchant tous les cordons d'alimentation secteur du système ou de la prise murale.
- Déconnectez l'ensemble des câbles et lignes de télécommunication qui sont connectés au système.
- Mettez toutes les vis ou autres attaches de côté lorsque vous retirez les panneaux d'accès. Une fois que vous avez terminé d'accéder à l'intérieur du produit, refixez le panneau d'accès avec les vis ou attaches d'origine.
- N'essayez pas d'accéder à l'intérieur du bloc d'alimentation. Il ne contient aucune pièce réparable. Renvoyez-le au fabricant en cas de problème.
- Mettez le serveur hors tension et débranchez tous les cordons d'alimentation avant d'ajouter ou de remplacer tout composant non connectable à chaud.
- Lorsque vous remplacez le bloc d'alimentation à chaud, débranchez le cordon du bloc d'alimentation en cours de remplacement avant de retirer le bloc du serveur.

Attention: Si le serveur a été utilisé, les processeurs et dissipateurs de chaleur installés peuvent être chauds. À moins que vous n'ajoutiez ou ne retiriez un composant connectable à chaud, laissez le système refroidir avant d'ouvrir les panneaux. Pour éviter tout risque d'entrer en contact avec un composant chaud lors d'une installation à chaud, prenez toutes les précautions nécessaires lorsque vous retirez ou installez des composants connectables à chaud.

Attention: Pour éviter de vous blesser, ne touchez pas les pales de ventilateur en mouvement. Si votre système est fourni avec une protection sur le ventilateur, ne mettez pas le système en route sans la protection en place.

Avertissements sur le montage en rack

Le rack doit être fixé à un support inamovible pour éviter qu'il ne bascule lors de l'extension d'un serveur ou d'un élément de l'équipement. Le rack doit être installé conformément aux instructions du fabricant.

Installez les équipements dans le rack en partant du bas, en plaçant le plus lourd en bas du rack.

N'étendez qu'un seul élément de l'équipement à partir du rack à la fois.

Vous êtes responsable de l'installation d'un disjoncteur principal d'alimentation pour la totalité du rack. Ce disjoncteur principal doit être rapidement accessible et doit être étiqueté comme contrôlant toute l'unité, et pas uniquement le ou les serveurs.

Pour éviter tout risque d'électrocution, le rack et chaque élément de l'équipement installé dans le rack doivent être correctement reliés à la terre.

Décharges électrostatiques†(ESD)

Attention: *Les décharges électrostatiques (ESD) peuvent endommager les lecteurs de disque dur, les cartes et d'autres pièces. Il est fortement conseillé d'effectuer l'ensemble des procédures décrites à un poste de travail protégé contre les ESD. Au cas où aucun poste de ce type ne serait disponible, protégez-vous contre les ESD en portant un bracelet antistatique relié à la masse du châssis (n'importe quelle surface métallique non peinte) de votre serveur lorsque que vous manipulez les pièces.*

Manipulez toujours les cartes avec précaution. Elles peuvent être extrêmement sensibles aux ESD. Ne tenez les cartes que par leurs bords. Après avoir retiré une carte de son emballage de protection ou du serveur, placez-la sur une surface reliée à la terre, exempte de charge statique, composants orientés vers le haut. Utilisez si possible un tapis de mousse conducteur, mais pas l'emballage de la carte. Veillez à ce que la carte ne glisse sur aucune surface.

Autres risques

Remplacement de la pile

Attention: *Il existe un risque d'explosion si la pile n'est pas correctement remplacée. Lors du remplacement de la pile, utilisez uniquement celle recommandée par le fabricant du matériel.*

Mettez la pile au rebut en vous conformant aux réglementations locales.

N'essayez pas de recharger une pile.

N'essayez pas de démonter, de percer ou d'endommager la pile d'une quelconque façon.

Refroidissement et ventilation

Attention: *Routez les câbles avec précaution comme indiqué pour minimiser les blocages de circulation d'air et les problèmes de refroidissement.*

Afin de permettre une ventilation et un refroidissement corrects, ne mettez le système en marche que lorsque les panneaux du châssis sont en place. L'utilisation du système sans les panneaux peut endommager les composants système. Pour installer les panneaux :

- Vérifiez tout d'abord que vous n'avez pas oublié d'outils ou de composants détachés à l'intérieur du système.
- Vérifiez que les câbles, les cartes d'extension et les autres composants sont correctement installés.
- Fixez les panneaux au châssis en suivant les instructions du produit.

Périphériques laser

Attention: *Pour éviter tout risque d'exposition aux rayonnements et/ou de dommage personnel:*

- *N'ouvrez pas l'enceinte d'un périphérique laser.*
- *Les périphériques laser ne sont pas réparables par l'utilisateur.*
- *Retournez-les au fabricant en cas de problème.*

Español

Información de seguridad del servidor

Este documento se aplica a las tarjetas de servidor de Intel[®], las carcassas de servidor de Intel[®] (montaje en bastidor y en pedestal) y los dispositivos periféricos. Para reducir el riesgo de daños corporales, descargas eléctricas, fuego y en el equipo, lea este documento y preste atención a todas las advertencias y precauciones de esta guía antes de instalar o mantener el producto de servidor de Intel[®].







En el caso de que haya diferencias entre la información para un producto en particular contenida en este documento y la información proporcionada con dicho producto o en el sitio Web, la documentación del producto es la que prevalece.

Sólo personal técnico cualificado debe montar y prestar los servicios para el servidor.

Debe ceñirse a las directrices de esta guía y a las instrucciones de montaje de los manuales del servidor para asegurar y mantener el cumplimiento con las certificaciones y homologaciones existentes de los productos. Utilice sólo los componentes descritos y homologados que se especifican en esta guía. El uso de otros productos o componentes anulará la homologación UL y otras certificaciones oficiales del producto, pudiendo dejar de ser compatible con las normativas locales de los países en los que se comercializa.

Advertencias y precauciones sobre seguridad

Para reducir la posibilidad de que se produzcan lesiones personales o daños en la propiedad, antes de empezar a instalar el producto, lea, observe y cumpla toda la información e instrucciones de seguridad siguientes. Puede que se utilicen los siguientes símbolos de seguridad en la documentación y es posible que aparezcan en el producto o en su embalaje.

PRECAUCIÓN	Indica la existencia de un riesgo que podría causar lesiones personales o daños en la propiedad leves si no se tiene en cuenta la PRECAUCIÓN.
ADVERTENCIA	Indica la existencia de un riesgo que podría causar lesiones personales graves si no se tiene en cuenta la ADVERTENCIA.
	Indica un riesgo potencial si no se tiene en cuenta la información indicada.
	Indica riesgo de descargas eléctricas que podrían causar lesiones graves o la muerte si no se siguen las instrucciones de seguridad.
	Indica componentes o superficies calientes.
	Indica que no se deben tocar las aspas de los ventiladores, ya que de lo contrario se podrían producir lesiones.
	Indica que es necesario desenchufar los cables de alimentación de CA para desconectar la alimentación de CA
	Recicle por favor la batería

Aplicaciones y usos previstos

Este producto ha sido evaluado como equipo de tecnología informática (ITE) que puede instalarse en oficinas, escuelas, salas de equipos informáticos o lugares de ámbito comercial similares. Es posible que sea necesario llevar a cabo una evaluación adicional para comprobar si este producto es apropiado para otras categorías de productos y entornos además de las aplicaciones informáticas (por ejemplo, soluciones médicas, industriales, residenciales, sistemas de alarma y equipos de pruebas).

Selección de la ubicación

El sistema se ha diseñado para funcionar en un entorno normal de oficinas. Seleccione una ubicación que esté:

- Limpia, seca y libre de macropartículas en suspensión en el aire (que no sean el polvo habitual de la habitación).
- Bien ventilada y alejada de fuentes de calor, incluida la luz solar directa y los radiadores.
- Alejada de fuentes de vibración o de golpes físicos.
- Aislada de campos electromagnéticos producidos por dispositivos eléctricos.
- En zonas propensas a tormentas eléctricas, se recomienda que conecte el servidor a un supresor de sobretensiones y desconecte las líneas de telecomunicaciones al módem durante una tormenta eléctrica.
- Provista de una toma de corriente alterna correctamente conectada a tierra.
- Provista de espacio suficiente para acceder a los cables de la fuente de alimentación ya que constituyen la desconexión principal de la alimentación.

Manipulación del equipo

Reduzca el riesgo de daños personales o en el equipo:

- Respete los requisitos de sanidad y seguridad laborales de su país cuando traslade y levante el equipo.
- Utilice medios mecánicos u otros que sean adecuados al trasladar o levantar el equipo.
- Para que el peso sea menor para manipularlo con más facilidad, extraiga los componentes que sean de fácil extracción.

Advertencias de alimentación y eléctricas

Precaución: El botón de encendido, indicado con la marca del modo de reposo o stand-by, NO DESCONECTA completamente la alimentación de CA del sistema, ya que el modo de reposo de 5 V sigue activo mientras el sistema está enchufado. Para desconectar el sistema debe desenchufar el cable de alimentación de CA de la toma de la pared. Puede usar más de un cable de alimentación de CA con el sistema. Asegúrese de que todos los cables de alimentación de CA estén desenchufados. Asegúrese de que los cables de alimentación de CA estén desenchufado antes de abrir la carcasa, agregar o extraer cualquier componente que no es de conexión en funcionamiento.

Algunas fuentes de alimentación de electricidad de los servidores de Intel utilizan el polo neutral del fuselaje. Para evitar riesgos de choques eléctricos use precauciones al trabajar con las fuentes de alimentación que utilizan el polo neutral de fuselaje.

No intente modificar ni utilizar un cable de alimentación de CA si no es del tipo exacto requerido. Se necesita un cable de CA para cada fuente de alimentación del sistema.

La fuente de alimentación de este producto no contiene piezas que puedan ser reparadas por el usuario. No abra la fuente de alimentación. Dentro de la fuente de alimentación puede haber niveles de tensión, corriente y energía peligrosos. Devuélvala al fabricante para repararla.

Al reemplazar una fuente de alimentación de conexión en funcionamiento, desenchufe el cable de alimentación de la fuente de alimentación que va a reemplazar antes de extraerla del servidor.

Para evitar el riesgo de descargas eléctricas, antes de abrir el servidor, apáguelo, desconecte el cable de alimentación, los sistemas de telecomunicaciones, las redes y los módems conectados al mismo.

Advertencias sobre el cable de alimentación

Si no se ha proporcionado con el producto ningún cable de alimentación de CA, adquiera alguno cuyo uso esté aprobado en su país.

Precaución: Para evitar descargas eléctricas o fuego, revise los cables de alimentación que usará con el producto tal y como se describe a continuación:

- No intente modificar ni utilizar los cables de alimentación de CA si no son exactamente del modelo especificado para ajustarse a las tomas de corriente conectadas a tierra
- Los cables de alimentación deben reunir los siguientes requisitos:
- El cable de alimentación debe disponer de una capacidad nominal de corriente eléctrica mayor que la capacidad especificada en el producto.
- El cable de alimentación debe disponer de una patilla o contacto de conexión a tierra que sea apto para la toma de corriente.
- Los cables de la fuente de alimentación son los dispositivos de desconexión principales a la corriente alterna. El enchufe o enchufes de zócalo deben encontrarse cerca del equipo y el acceso a ellos debe poderse efectuar de forma inmediata con el fin de desconectarlos.

- Los cables de la fuente de alimentación deben estar conectados a los enchufes con una toma de tierra adecuada.

Advertencias el acceso al sistema

Precaución: Para evitar lesiones personales o daños en la propiedad, se aplican las siguientes instrucciones de seguridad siempre que se acceda al interior del producto:

- Apague todos los dispositivos periféricos conectados a este producto.
- Pulse el botón de alimentación para apagar el sistema.
- Desconecte la alimentación de CA desenchufando los cables de alimentación de CA del sistema o de la toma de corriente alterna.
- Desconecte todos los cables y líneas de telecomunicación que estén conectados al sistema.
- Guarde todos los tornillos o elementos de fijación cuando retire las cubiertas de acceso. Cuando termine de operar en el interior del producto, vuelva a colocar los tornillos o los elementos de fijación originales de la cubierta de acceso.
- No acceda al interior de la fuente de alimentación. No hay elementos en la fuente de alimentación que usted pueda reparar y utilizar. Devuélvala al fabricante para repararla.
- Apague el servidor y desconecte todos los cables de alimentación antes de agregar o reemplazar cualquier componente que no es de conexión en funcionamiento.
- Al reemplazar una fuente de alimentación de conexión en funcionamiento, desenchufe el cable de alimentación de la fuente de alimentación que va a reemplazar antes de extraerla del servidor.

Precaución: Si el servidor se ha estado ejecutando, los procesadores y disipadores de calor estarán recalentados. A no ser que esté instalando o extrayendo un componente de conexión en funcionamiento, deje que el sistema se enfríe antes de abrir las cubiertas. Para que no llegue a tocar los componentes que estén calientes cuando esté realizando una instalación de conexión en funcionamiento, tenga cuidado al extraer o instalar los componentes de conexión en funcionamiento.

Precaución: Para evitar posibles daños, no toque las aspas en movimiento de los ventiladores. Si el sistema se le ha suministrado con una protección para el ventilador, asegúrese de que cuando esté funcionando el sistema la protección esté en su sitio.

Advertencias sobre el montaje en bastidor

El bastidor del equipo se debe sujetar con un soporte fijo para evitar que se caiga cuando se extraiga un servidor o una pieza del mismo. El bastidor del equipo debe instalarse siguiendo las instrucciones del fabricante del bastidor.

Instale el equipo en el bastidor comenzando desde la parte de abajo, con el equipo más pesado en la parte inferior del bastidor.

Extraiga las piezas del equipo del bastidor de una a una.

El usuario es el responsable de la instalación de un dispositivo de desconexión de la alimentación principal para toda la unidad del bastidor. El acceso a este dispositivo de desconexión deberá ser de fácil acceso y deberán incluirse indicaciones que lo identifiquen como el control de alimentación eléctrica de toda la unidad, no sólo de los servidores.

Para evitar el riesgo de descargas eléctricas, deberá instalar una conexión a tierra apropiada para el bastidor y para cada pieza del equipo instalada en el mismo.

Descarga electrostática (ESD)

Precaución: *Las descargas electrostáticas pueden dañar las unidades de disco, las tarjetas y otros componentes. Recomendamos que realice todos los procedimientos en una estación de trabajo protegida contra descargas electrostáticas. En caso de que no haya una disponible, protéjase de alguna forma contra las descargas llevando un brazalete antiestático conectado a la toma de tierra de la carcasa (cualquier superficie de metal que no esté pintada) del servidor cuando manipule las piezas.*

Manipule siempre las tarjetas con el máximo cuidado. Pueden ser sumamente sensibles a las descargas electrostáticas. Sujételas sólo por los bordes. Una vez extraída la tarjeta de su envoltorio de protección o del servidor, colóquela con el lado de los componentes hacia arriba sobre una superficie con toma de tierra y sin carga estática. Utilice una almohadilla de espuma conductora si dispone de ella, pero nunca el envoltorio de la tarjeta. No deslice la tarjeta sobre ninguna superficie.

Sustitución de la batería

Precaución: Existe el peligro de explosión si la batería no se reemplaza correctamente. Al reemplazar la batería, utilice sólo la batería recomendada por el fabricante del equipo.

Deseche las baterías respetando la normativa local.

No intente recargar la batería.

No intente desmontar, pinchar o causar cualquier otro desperfecto a una batería.

Enfriamiento y circulación de aire

Precaución: El tendido de los cables debe realizarse cuidadosamente tal y como se le indica para reducir al mínimo los problemas de obstrucción de la ventilación y de refrigeración.

Para conseguir una refrigeración y corriente de aire adecuadas, compruebe que cuando sistema esté funcionando, las cubiertas de la carcasa están instaladas. Si utiliza el sistema sin las cubiertas, podría dañar sus componentes. Para instalar las cubiertas:

- *Compruebe primero que no ha dejado herramientas o piezas sueltas dentro del sistema.*
- *Compruebe que los cables, tarjetas adicionales y otros componentes están instalados correctamente.*
- *Sujete las cubiertas a la carcasa siguiendo las instrucciones del producto.*

Periféricos o dispositivos láser

Precaución: Para evitar el riesgo de la exposición a radiaciones o de daños personales:

- *No abra la caja de ningún periférico o dispositivo láser*
- *Los periféricos o dispositivos láser no pueden ser reparados por el usuario*
- *Haga que el fabricante los repare.*

简体中文

服务器安全信息

本文档适用于 Intel® 服务器主板、Intel® 服务器机箱（基座和机架固定件）和已安装的外设。为减少人身伤害、电击、火灾以及设备损坏的危险，请在安装或维护 Intel® 服务器产品之前阅读本文档并遵循本指南中的所有警告和预防措施。





如果本文档中的信息与特定产品的随附信息或 Web 站点信息之间存在不一致，请以产品文档为准。

服务器须由合格的技术人员进行集成和维护。

必须遵守本指南的规定和服务器手册的装配指导，以确保符合现有的产品认证和审批。仅使用本指南中描述和规定的指定组件。使用其他产品 / 组件将使产品的 UL 认证和其他管理审批无效，并可能导致产品不符合销售地的产品法规。

安全警告与注意事项

为避免人身伤害与财产损失，安装本产品之前，请阅读以下所有安全指导和信息。下面所列的安全符号可能在整个文档中使用并可能标注于产品和 / 或产品包装之上。

注意	表示如果无视此“?? ? 项”?? ? ? ? ? 轻微人身伤害或财产损失的危险。
警告	表示如果无视此“?? ”?? ? ? ? ? ? ? 严重人身伤害的危险。
	表示如果无视所示信息，即存在潜在的危险。
	表示如果不遵守安全指导，存在可导致严重伤害或死亡的电击危险。
	表示灼热组件或表面。
	表示请勿触摸风机叶片，否则可能致伤。
	表示拔下所有交流电线，断开交流电源

预期应用使用

根据评估，本产品为信息技术设备 (ITE)，可安装在办公室、学校、计算机房和类似的商业场所。本产品对于非 ITE 应用的其他产品种类和环境（如医疗、工业、住宅、报警系统和测试设备）的适用性尚有待进一步的评估。

场地选择

本系统专为在典型办公环境运行而设计。请选择符合以下条件的地点：

- 清洁、干燥，无气载微粒（而非一般的室内尘埃）。
- 通风良好，远离热源（包括直接日晒和散热器）。
- 远离振动源或物理震动。
- 与电气设备产生的强大电磁场隔离。
- 在易受闪电袭击的地区，我们建议将系统插入电涌抑制器并在闪电期间断开通信线路与调制解调器之间的连接。
- 提供正确接地的墙壁插座。
- 提供足够的空间，以便拿取电源供应线，因为这是本产品的主要电源断开器。

设备操作规范

减少人身伤害或设备受损的危险：

- 移举设备时遵守当地的职业健康与安全要求。
- 借助机械手段或其他合适的手段移举设备。
- 拆除一切易分离组件，以降低重量并方便操作。

电源与电气警告

注意事项

电源按钮（如待机电源标记所示）并不能完全关闭系统的交流电源，只要系统已接通电源，就存在 5V

待机电源。要从系统切断电源，须从墙壁电源插座中拔下交流电线。您的系统可能不止使用一根交流电线。请确保所有的交流电线都已拔下。打开机箱或增加或删除任何热插拔组件之前，确保交流电线已拔下。

若非所需的确切类型，请勿尝试修改或使用交流电线。系统的每个电源供应设备都需要一根单独的交流电线。

本产品的电源供应设备包含非用户维修部件。请勿打开电源供应设备。电源供应设备包含非常危险的电压级、电流级和能量级。请与生产商联系维修事宜。

替换热插拔电源供应设备时，请先拔下需替换的电源供应设备上的电源线，再将其从服务器上移除。

为避免电击，请在打开服务器之前，关闭服务器并断开服务器上连接的电源线、电信系统、网络和调制解调器。

电源线警告

如果产品未提供交流电线，请购买一根您所在国家批准使用的交流电线。

注意事项

为避免电击或火灾危险，请按如下所述对产品所用的电源线进行检查：

- 若非所需的符合接地插座的确切类型，请勿尝试修改或使用交流电线
- 电源线须符合以下标准：
 - 电源线的电气额定值须大于产品上标注的电流额定值。
 - 电源线须拥有适合插座的安全接地插头或触点。
- 电源线为交流电源的主要断开设备。插座须靠近设备并可随时断开。
- 电源线须插入所提供的拥有合适接地的插座。

系统使用警告

注意事项

为避免人身伤害或财产损失，无论何时检查产品内部，以下安全指导都适用：

- 关闭所有与本产品相连的外设。
- 按下电源按钮至关闭状态，关闭系统。
- 从系统或墙壁插座上拔下所有交流电线，断开交流电源。
- 断开与系统相连的所有线缆和通信线路。
- 卸除舱口盖时，保留所有螺钉及其他紧固件。完成产品内部检查之后，请用螺钉或紧固件重新固定舱口盖。
- 请勿打开电源供应设备。电源供应设备内没有可维修部件。请与生产商联系维修事宜。
- 增加或替换任何非热插拔组件之前，请关闭服务器电源并断开所有电源线。
- 替换热插拔电源供应设备时，请先拔下需替换的电源供应设备上的电源线，然后再从服务器上移除电源供应设备。

注意事项

如果服务器一直在运行，任何已安装的处理器和吸热设备都可能很热。除非要增加或移除热插拔组件，否则请待系统冷却后再开盖。为避免在热插拔组件安装过程中接触灼热组件，移除或安装热插拔组件时务须小心。

注意事项

为避免受伤，请勿触摸运转的风机叶片。如果系统的风机上配有防护装置，请勿卸下风机防护装置运行系统。

机架固定件警告

设备的机架须固定在稳固的支座上，以防从中安装服务器或设备时倒塌。须按照机架生产商提供的安装说明进行安装。

从下往上将设备安装在机架上，最重的设备安装在机架的最底层。

一次只从机架上安装一件设备。

您须负责安装整个机架装置的主要电源断开设备。此主要断开设备须随时可用，且须标明为控制整个装置（而不仅限于服务器）的电源。

为避免潜在的电击危险，须对机架及其上所安装的每一件设备实行正确的安全接地。

静电放电（ESD）

注意事项

ESD 会损坏磁盘驱动器、主板及其他部件。我们建议您执行 ESD 工作站的所有步骤。如果没有 ESD

工作站，则采取一些静电放电保护措施，操作部件时，戴上与服务器上的机箱接地或任何未喷漆金属表面连接的防静电腕带。

操作主板时始终保持小心。它们可能对 ESD

非常敏感。拿持主板时只接触边缘。从保护包装中或从服务器上取出主板后，请将主板组件侧面朝上放置于无静电的接地表面上。请使用导电泡沫垫（若有），不要使用主板包装。请勿将主板在任何表面上滑动。

其他危险

替换电池

注意事项

不正确替换电池可能导致爆炸危险。替换电池时，请只使用设备生产商推荐使用的电池。

请按当地法规处置电池。

请勿对电池充电。

请勿拆卸、刺穿或以其他方式损坏电池。

冷却和气流

注意事项

按照说明小心布置线缆，尽量减少气流阻塞和冷却问题。

为保证适当的冷却和气流，运行系统时请确保机箱盖已安装。未安装机箱盖即运行系统可能导致系统部件受损。安装机箱盖的步骤如下：

- 首先检查并确保系统内没有遗留的未固定工具或部件。
- 检查线缆、内插板和其他组件已正确安装。
- 按产品说明安装机箱盖。

激光外设或激光设备

注意事项

为避免幅射暴露和 / 或人身伤害：

- 请勿打开任何激光外设或激光设备的外壳
- 激光外设或激光设备为非用户维修设备

请与生产商联系维修事宜

C Regulatory and Compliance Information

Product Regulatory Compliance

Product Safety Compliance

The Server Board SE7230NH1-E complies with the following safety requirements:

- UL60950 - CSA 60950(USA / Canada)
- EN60950 (Europe)
- IEC60950 (International)
- CB Certificate & Report, IEC60950 (report to include all country national deviations)
- GOST R 50377-92 - Listed on one System License (Russia)
- Belarus License - Listed on System License (Belarus)
- CE - Low Voltage Directive 73/23/EEE (Europe)
- IRAM Certification (Argentina)

Product EMC Compliance - Class A Compliance

Note: *Legally this product is required to comply with Class A emission requirements as it is intended for a commercial type market place. Intel targets 10db margin to Class A Limits.*

The Intel® Server Board [name] has been tested and verified to comply with the following electromagnetic compatibility (EMC) regulations when installed a compatible Intel® host system. For information on compatible host system(s) refer to Intel's Server Builder Web site or contact your local Intel representative.

- FCC /ICES-003 - Emissions (USA/Canada) Verification
- CISPR 22 - Emissions (International)
- EN55022 - Emissions (Europe)
- EN55024 - Immunity (Europe)
- CE - EMC Directive 89/336/EEC (Europe)
- AS/NZS 3548 Emissions (Australia / New Zealand)
- BSMI CNS13438 Emissions (Taiwan)
- GOST R 29216-91 Emissions - Listed on one System License (Russia)
- GOST R 50628-95 Immunity -Listed on one System License (Russia)
- Belarus License - Listed on one System License (Belarus)

- RRL MIC Notice No. 1997-41 (EMC) & 1997-42 (EMI) (Korea)

Certifications / Registrations / Declarations

- UL Certification (US/Canada)
- CE Declaration of Conformity (CENELEC Europe)
- FCC/ICES-003 Class A Attestation (USA/Canada)
- C-Tick Declaration of Conformity (Australia)
- MED Declaration of Conformity (New Zealand)
- BSMI Certification (Taiwan)
- GOST - Listed on one System License (Russia)
- Belarus - Listed on one System License (Belarus)
- RRL Certification (Korea)
- Ecology Declaration (International)

Product Regulatory Compliance Markings

This product is marked with the following Product Certification Markings:

Table 7. Product Certification Markings



Regulatory Compliance	Country	Marking
UL Mark	USA/Canada	
CE Mark	Europe	
FCC Marking (Class A)	USA	This device complies with Part 15 of the FCC Rules. Operation of this device is subject to the following two conditions: (1) This device may not cause harmful interference, and (2) This device must accept any interference received, including interference that may cause undesired operation. Manufactured by Intel Corporation
EMC Marking (Class A)	Canada	CANADA ICES-003 CLASS A CANADA NMB-003 CLASSE A

Table 7. Product Certification Markings

Regulatory Compliance	Country	Marking
BSMI Marking (Class A)	Taiwan	 <div data-bbox="899 491 1338 604" style="border: 1px solid black; padding: 5px;"> <p>警告使用者： 這是甲類的資訊產品，在居住的環境中使用時，可能會造成射頻干擾，在這種情況下，使用者會被要求採取某些適當的對策</p> </div>
RLL MIC Mark	Korea	

Electromagnetic Compatibility Notices

FCC (USA)

This device complies with Part 15 of the FCC Rules. Operation is subject to the following two conditions: (1) this device may not cause harmful interference, and (2) this device must accept any interference received, including interference that may cause undesired operation.

For questions related to the EMC performance of this product, contact:

Intel Corporation
5200 N.E. Elam Young Parkway
Hillsboro, OR 97124-6497
1-800-628-8686

This equipment has been tested and found to comply with the limits for a Class A digital device, pursuant to Part 15 of the FCC Rules. These limits are designed to provide reasonable protection against harmful interference in a residential installation. This equipment generates, uses, and can radiate radio frequency energy and, if not installed and used in accordance with the instructions, may cause harmful interference to radio communications. However, there is no guarantee that interference will not occur in a particular installation. If this equipment does cause harmful interference to radio or television reception, which can be determined by turning the equipment off and on, the user is encouraged to try to correct the interference by one or more of the following measures:

- Reorient or relocate the receiving antenna.
- Increase the separation between the equipment and the receiver.
- Connect the equipment to an outlet on a circuit other than the one to which the receiver is connected.
- Consult the dealer or an experienced radio/TV technician for help.

Any changes or modifications not expressly approved by the grantee of this device could void the user's authority to operate the equipment. The customer is responsible for ensuring compliance of the modified product.

Only peripherals (computer input/output devices, terminals, printers, etc.) that comply with FCC Class A or B limits may be attached to this computer product. Operation with noncompliant peripherals is likely to result in interference to radio and TV reception.

All cables used to connect to peripherals must be shielded and grounded. Operation with cables, connected to peripherals, that are not shielded and grounded may result in interference to radio and TV reception.

Industry Canada (ICES-003)

Cet appareil numérique respecte les limites bruits radioélectriques applicables aux appareils numériques de Classe A prescrites dans la norme sur le matériel brouilleur: "Appareils Numériques", NMB-003 édictée par le Ministre Canadien des Communications.

This digital apparatus does not exceed the Class A limits for radio noise emissions from digital apparatus set out in the interference-causing equipment standard entitled: "Digital Apparatus," ICES-003 of the Canadian Department of Communications.

Europe (CE Declaration of Conformity)

This product has been tested in accordance too, and complies with the Low Voltage Directive (73/23/EEC) and EMC Directive (89/336/EEC). The product has been marked with the CE Mark to illustrate its compliance.

Taiwan Declaration of Conformity (BSMI)

警告使用者：
這是甲類的資訊產品，在居住的環境中使用時，可能會造成射頻干擾，在這種情況下，使用者會被要求採取某些適當的對策

The BSMI Certification Marking and EMC warning is located on the outside rear area of the product.

Korean Compliance (RRL)



1. 기기의 명칭(모델명) :
2. 인증번호 :
3. 인증받은 자의 상호 :
4. 제조년월일 :
5. 제조자/제조국가 :

English translation of the notice above:

1. Type of Equipment (Model Name): On License and Product
2. Certification No.: On RRL certificate. Obtain certificate from local Intel representative
3. Name of Certification Recipient: Intel Corporation
4. Date of Manufacturer: Refer to date code on product
5. Manufacturer/Nation: Intel Corporation/Refer to country of origin marked on product

D Intel® Server Issue Report Form

Note: An on-line / automatic submission version of this form is available at <http://support.intel.com/support/motherboards/server/SE7230NH1-E/>. For the fastest service, please submit your form via the Internet.

Date Submitted: _____

Company Name: _____

Contact Name: _____

Email Address: _____

Intel Server Product: _____

Priority (Critical, Hot, High, Low): _____

Brief Problem Description. Provide a brief description below. See the last page for space to include a detailed problem description.

Board / Chassis Information

Baseboard Revision - PBA#: _____

Baseboard Serial Number: _____

Chassis Model: _____

CPU1 Speed/Stepping/Spec: _____

System BIOS Version: _____

HSC Firmware Version: _____

DIMM Configuration

DIMM1A MB and Vendor / part number: _____

DIMM1B MB and Vendor / part number: _____

DIMM2A MB and Vendor / part number: _____

DIMM2B MB and Vendor / part number: _____

Operating System Information

Operating System: _____

Version: _____

Service Pack: _____

Add-in Card, Peripheral, Video, NIC

Check each box below as applicable, and provide the requested information.

Peripheral Card or Peripheral Description Driver Revision IRQ # I/O Base Address NIC

X	Peripheral	Description	Driver Revision	IRQ	I/O Base Address	FW Revision
	Pedestal Slots					
	PCI (32bit/33MHz) Slot 1					
	PCI (32bit/33MHz) Slot 2					
	PCI Express* x4 (x1 Lane - Slot 3)					
	PCI Express* x8 (x4 Lane - Slot 4)					
	PCI-X (64bit/ 100MHz) (Slot 5)					
	PCI Express* x8 (x8 Lane - Slot 6)					
	Full-height Riser					
	PCI Riser Slot					
	Video					
	On-board Video					
	Add-in Video					
	NIC					
	On-Board NIC1					
	On-Board NIC2					

