



Intel[®] Carrier Grade Server TIGPT1U

Technical Product Specification



Revision 1.1

November, 2007

Modular Communications Platform Division

Revision History

Date	Revision Number	Modifications
June 2004	1.0	Initial release
November 2007	1.1	Add system weight(s) to table 2-5; Remove "Intel Secret" from footers;

Disclaimers

THIS SPECIFICATION IS PROVIDED "AS IS" WITH NO WARRANTIES WHATSOEVER, INCLUDING ANY WARRANTY OF MERCHANTABILITY, NONINFRINGEMENT, FITNESS FOR ANY PARTICULAR PURPOSE, OR ANY WARRANTY OTHERWISE ARISING OUT OF ANY PROPOSAL, SPECIFICATION OR SAMPLE. Intel disclaims all liability, including liability for infringement of any proprietary rights, relating to use of information in this specification. No license, express or implied, by estoppel or otherwise, to any intellectual property rights is granted herein.

The Intel® Carrier Grader Server TIGPT1U may contain design defects or errors known as errata which may cause the product to deviate from published specifications. Current characterized errata are available on request.

This document is an intermediate draft for comment only and is subject to change without notice. Readers should not design products based on this document.

I²C is a two-wire communications bus/protocol developed by Philips. SMBus is a subset of the I²C bus/protocol and was developed by Intel. Implementations of the I²C bus/protocol or the SMBus bus/protocol may require licenses from various entities, including Philips Electronics N.V. and North American Philips Corporation.

Copyright © Intel Corporation 2007.

*Other brands and names are the property of their respective owners.

Table of Contents

1. Introduction	1
1.1 Document Structure and Outline.....	1
2. System Overview	2
2.1 System Features.....	2
2.2 Chapter Structure and Outline.....	3
2.3 Introduction	4
2.4 External Chassis Features	8
2.4.1 Front View of Chassis	8
2.4.2 Front Panel	8
2.4.3 Chassis Peripheral Bay and Hot-Plug SCSI Hard Drive Bays.....	10
2.4.4 Rear View of Chassis.....	13
2.5 Internal Chassis Features	15
2.5.1 Telecom SE7210TP1-E Server Baseboard	15
2.5.2 Full-Height, Full-Length PCI Adapter Subsystem.....	16
2.5.3 Power Subsystem	17
2.5.4 Cooling Subsystem	18
2.6 Server Management	19
2.6.1 Baseboard Management Controller	19
2.7 Specifications.....	20
2.7.1 Environmental Specifications	20
2.7.2 Physical Specifications	21
3. Cables and Connectors	22
3.1 Chapter Structure and Outline	22
3.2 Interconnect Block Diagram	23
3.3 Cable and Interconnect Descriptions	24
3.4 Exteranly-Accessible Interconnects	25
3.4.1 Keyboard and Mouse Ports.....	25
3.4.2 Serial Ports	26
3.4.3 Video Port	27
3.4.4 Universal Serial Bus (USB) Interface	27
3.4.5 Ethernet Connector.....	28

3.4.6	Telco Alarms Connector.....	28
3.4.7	AC Power Input for AC-Input Power Supply.....	28
3.4.8	DC Power Input for DC-Input Power Supply	29
4.	Extended Front Panel System Board	30
4.1	Features.....	30
4.2	Chapter Structure and Outline	30
4.3	Introduction	31
4.4	Functional Description of Front Panel Switches, LEDs, and Relays	31
4.4.1	Front Panel Switches	31
4.4.2	Front Panel LEDs.....	32
4.4.3	System Status LEDs	32
4.4.4	System Fault LEDs	33
4.4.5	LED Color Selection.....	33
4.4.6	System Fault Relays	34
4.4.7	Server Management Bus (SMBus) Interface.....	34
4.5	Connector Information	35
4.5.1	Extended Front Panel Board USB Connector Pinout.....	37
4.5.2	Extended Front Panel Board uProcessor Power Connector Pinout.....	37
4.5.3	Extended Front Panel Board Front Panel Connector Pinout.....	38
4.5.4	Extended Front Panel Board Midplane Connector Pinout.....	38
4.5.5	Extended Front Panel Board Power/Signal Connector Pinout	39
4.5.6	Extended Front Panel Board Alarm/COM2 Connector Pinout.....	39
4.5.7	Extended Front Panel Board Baseboard Power Connector Pinout.....	40
4.5.8	Extended Front Panel Board COM2/USB Connector Pinout	40
4.5.9	Extended Front Panel Board NEBS Riser Power Connector Pinout	40
4.6	SCSI Power Subsystem.....	41
4.6.1	SCSI Drive Power Control.....	41
4.6.2	Internal SCSI Drive Power Switching	41
4.6.3	SCSI Drive Status LEDs	42
4.7	Specifications.....	43
4.7.1	Electrical Specifications	43
5.	Power Interconnect System Board.....	44
5.1	Features.....	44

5.2	Chapter Structure and Outline	44
5.3	Functional Description of Power Interconnect System Board	44
5.4	Connector Description	45
5.4.1	Connector Mating to the Power Supply Pinout.....	45
5.4.2	Connector Mating to the Extended Front Panel System Board Pinout.....	46
6.	NEBS 3.3 V Riser Board.....	47
6.1	Chapter Structure and Outline	47
6.2	Functional Description	47
6.3	Connector Interface	48
6.3.1	NEBS Riser Power Connector Pinout.....	50
6.4	Electrical Specification	51
7.	Midplane Board	52
7.1	Chapter Structure and Outline	52
7.2	Introduction	52
7.3	Functional Description	53
7.3.1	Midplane System Board SCSI Subsystem Block Diagram.....	53
7.3.2	SCSI Bus	54
7.3.3	SCA2 Connector Interlocks.....	54
7.3.4	Signal Descriptions	54
7.4	Connector Interface	56
7.4.1	Midplane Power/Signal Connector Pinout.....	57
7.4.2	Midplane SCSI Connector Pinout and SCSI ID settings	57
7.5	Specifications.....	57
7.5.1	Electrical Specifications	57
8.	DC Power Subsystem	58
8.1	Features.....	58
8.2	Chapter Structure and Outline	58
8.3	Introduction	58
8.4	Mechanical Interface.....	59
8.4.1	Power Supply Cage Mechanical Outline.....	59
8.4.2	DC Input Terminal Block Connector.....	60
8.4.3	DC Output Connector	61
8.4.4	Power Supply Module LED Indicators.....	63

8.5	Electrical Requirements	63
8.5.1	DC Input Voltage Specification	63
8.5.2	Dual DC Input	63
8.5.3	DC Output Current Specifications	64
9.	AC Power Subsystem	65
9.1	Features.....	65
9.2	Chapter Structure and Outline	65
9.3	Introduction	65
9.4	Mechanical Interface.....	66
9.4.1	Power Supply Cage Mechanical Outline.....	66
9.4.2	AC Input Connector	66
9.4.3	DC Output Connector	67
9.4.4	Power Supply Module LED Indicators.....	69
9.5	Electrical Requirements	69
9.5.1	AC Input Voltage Specification.....	69
10.	Regulatory Specifications	70
10.1	Safety Compliance	70
10.2	Electromagnetic Compatibility.....	70
10.3	CE Mark	70
10.4	NEBS Compliance (DC Input Only)	71
10.5	ETSI Standards Compliance (DC Input Only).....	71
Appendix A: Glossary.....		72
Appendix B: Reference Documents		76

List of Figures

Figure 2-1. Intel® Carrier Grade Server TIGPT1U	4
Figure 2-2. Intel® Carrier Grade Server TIGPT1U (shown with top covers and bezel removed)	5
Figure 2-3. Intel® Carrier Grade Server TIGPT1U Block Diagram	7
Figure 2-4. Front View of System	8
Figure 2-5. Front View of System (shown with bezel removed)	8
Figure 2-6. Front Panel Details	9
Figure 2-7. Chassis Peripheral Bay and Hard Drive Bays	10
Figure 2-8. Peripheral Drive Bay	11
Figure 2-9. Drive Carrier Assembly	11
Figure 2-10. SCSI Hard Drive Bays	12
Figure 2-11. SCSI Hard Drive Carrier	13
Figure 2-12. Rear View of System	13
Figure 2-13. Telecom SE7210TP1-E Server Baseboard Block Diagram	15
Figure 2-14. Full-Height, Full-Length PCI Adapter Subsystem	17
Figure 2-15. System Fan Assemblies	18
Figure 3-1. Intel® Carrier Grade Server TIGPT1U Interconnect Block Diagram	23
Figure 3-2. Telco Alarms Connector	28
Figure 3-3. AC Power Input Connector	29
Figure 3-4. DC Power Input Connector	29
Figure 3-5. Terminal Lug	29
Figure 4-1. Extended Front Panel Board	31
Figure 4-2. Extended Front Panel Board Connector Location	36
Figure 5-1. Physical Layout of Power Interconnect System Board	44
Figure 6-1. Physical Layout of NEBS 3.3 V Riser Board	48
Figure 7-1. Midplane System Board SCSI Subsystem Block Diagram	53
Figure 7-2. Extended Front Panel Board Connector Location	56
Figure 8-1. Power Subsystem Enclosure Outline Drawing	59
Figure 8-2. DC Input Terminal Block	60
Figure 8-3. Terminal Lug	60
Figure 8-4. Terminal Block Polarity	60

Figure 8-5. Edge Finger Layout.....	62
Figure 9-1. Power Subsystem Enclosure Outline Drawing.....	66
Figure 9-2. Edge Finger Layout.....	68

List of Tables

Table 2-1. Intel® Carrier Grade Server TIGPT1U Feature List.....	2
Table 2-2. Front Panel Features	9
Table 2-3. System Features - Rear	14
Table 2-4. Environmental Specifications Summary	20
Table 2-5. Dimensions and Weight	21
Table 3-1. System Interconnect Descriptions.....	24
Table 3-2. Keyboard/Mouse PS/2 Connector Pin Out (J9A1)	25
Table 3-3. COM1: 9-pin Serial A Port Pin Out (J8A1)	26
Table 3-4. COM2: Serial Port Connector on Front Panel	26
Table 3-5. Video Connector	27
Table 3-6. Single USB Connector	27
Table 3-7. Magjack Connector (RJ45, 10/100/1000) Pin Out (J5A1, J6A2)	28
Table 3-8. Telco Alarms Connector.....	28
Table 4-1. Front Panel Switch Description	31
Table 4-2. LED Specifications	32
Table 4-3. Front Panel System Status LED Description.....	32
Table 4-4. Front Panel System Fault LED Description	33
Table 4-5. LED Color Selection	33
Table 4-6. Alarms SMBus I/O Mapping	34
Table 4-7. SCSI SMBus I/O Mapping.....	35
Table 4-8. Extended Front Panel System Board Connector Information.....	35
Table 4-9. Connector Housing Information.....	36
Table 4-10. 8-pin (1 x 8) USB J2G1 Connector.....	37
Table 4-11. 8-pin (2 x 4) uP Power J5A1 Connector.....	37
Table 4-12. 34-pin (2 x 17) Front Panel J8A1 Connector	38
Table 4-13. 12-pin (2 x 6) Mid-Plane J1E1 Connector	38
Table 4-14. 10-pin (2 x 5) Power/Signal J9A1 Connector	39
Table 4-15. 24-pin (2 x 12) Alarm/COM2 J9B1 Connector.....	39
Table 4-16. 20-pin (2 x 10) Baseboard Power J10A1 Connector	40
Table 4-17. 16-pin Baseboard Power J1A1 Connector	40

Table 4-18. 3-pin (1 x 3) NEBS Riser Power J3E1 Connector	40
Table 4-19. LED Activity Definitions	42
Table 4-20. Maximum Power Requirements (mA)	43
Table 5-1. 2 x 31 Connector Pinout to 250 Watt Power Supply	45
Table 5-2. 2 x 31 Connector Pinout to Extended Front Panel System Board.....	46
Table 6-1. Riser Card Slot Pin-out Common Signals	48
Table 6-2. PCI Card Connector Signals	49
Table 6-3. 3-pin (1 x 3) NEBS Riser Power J1A1 Connector	50
Table 7-1. LVD SCSI Bus Signals – J2L1, J4A1, J8A1	55
Table 7-2. Extended Front Panel System Board Connector Information.....	56
Table 7-3. Connector Housing Information.....	57
Table 7-4. 12-pin (2 x 6) Midplane J9L1 Connector	57
Table 7-5. MPB Power Requirements	57
Table 8-1. 250 Watt DC-input Power Supply DC Output Ratings.....	58
Table 8-2. Edge Finger Pinout	61
Table 8-3. LED Indicators.....	63
Table 8-4. DC Input Rating.....	63
Table 8-5. 250 W Load Ratings.....	64
Table 9-1. 250 Watt AC-input Power Supply DC Output Ratings.....	65
Table 9-2. Edge Finger Pinout	67
Table 9-3. LED Indicators.....	69
Table 9-4. AC Input Rating.....	69

1. Introduction

This document provides an overview of the Intel® Carrier Grade Server TIGPT1U (Telecom Industrial Grade Prescott 1U (1.75" high) and includes information on chassis hardware, cables, connectors, SE7210TP1-E System Baseboard, system boards, power subsystem, and regulatory requirements.

1.1 Document Structure and Outline

This document is organized into the following chapters:

- Chapter 1: Introduction**
Provides an overview of this document.
- Chapter 2: System Overview**
Provides an overview of the Intel® TIGPT1U server chassis hardware.
- Chapter 3: Cables and Connectors**
Describes the cables and connectors used to interconnect the system board set and the Intel® TIGPT1U components.
- Chapter 4: Extended Front Panel System Board**
Describes the specifications of the extended front panel system board.
- Chapter 5: Power Interconnect System Board**
Describes the specifications of the power interconnect system board.
- Chapter 6: NEBS 3.3 V Riser Board**
Describes the specifications of the Network Equipment Building Specifications (NEBS) 3.3 V riser board.
- Chapter 7: Midplane Board**
Describes the specifications of the midplane board.
- Chapter 8: DC Power Subsystem**
Describes the specifications of the DC power subsystem.
- Chapter 9: AC Power Subsystem**
Describes the specifications of the AC power subsystem.
- Chapter 10: Regulatory Specifications**
Describes system compliance to regulatory specifications.

2. System Overview

This chapter describes the features of the Intel® Carrier Grade Server TIGPT1U chassis.

2.1 System Features

Table 2-1 provides a list and brief description of the features of the Intel® Carrier Grade Server TIGPT1U.

Table 2-1. Intel® Carrier Grade Server TIGPT1U Feature List

Feature	Description																
Compact, high-density system	Rack-mount server with a height of 1 U (1.75 inches) and a depth of 20.0 inches																
Configuration flexibility	Single processor capability in low profile and cost/value effective packaging Stand-alone system Intel® Pentium® 4 Processor with hyper-threading technology (3.0 GHz frequency, 1 M L2 cache, 800 MHz FSB, 90nm manufacturing technology)																
Serviceability	Front access to hot swap disk drives																
Availability	Integrated HostRAID™ ready to provide RAID 1 capability using two hot-swap Small Computer System Interface (SCSI) disk drives.																
Manageability	Remote management Emergency management port (Serial and LAN) IPMI 1.5 compliant Remote diagnostics support																
System-level scalability	4 GB DDR333/DDR400 unbuffered 184-pin DDR SDRAM DIMM memory support Single Intel® Pentium® 4 Processor support 1 Full Height Full Length 3.3 V/Universal 64-bit x 66 MHz PCI-X Slots 2 internal hot-swap SCSI disk drives (SCA support) 1 Low Profile CD-ROM																
Front panel	<table border="0"> <tr> <td>Power switch</td> <td>Hard Drive 0 Fault LED</td> </tr> <tr> <td>Reset switch</td> <td>Hard Drive 1 Fault LED</td> </tr> <tr> <td>NMI switch</td> <td>Telco power alarm fault LED/Relay</td> </tr> <tr> <td>ID switch</td> <td>Telco critical alarm fault LED/Relay</td> </tr> <tr> <td>Main power LED</td> <td>Telco major alarm fault LED/Relay</td> </tr> <tr> <td>HDD activity LED</td> <td>Telco minor alarm fault LED/Relay</td> </tr> <tr> <td>NIC activity LED</td> <td></td> </tr> <tr> <td>ID LED</td> <td></td> </tr> </table>	Power switch	Hard Drive 0 Fault LED	Reset switch	Hard Drive 1 Fault LED	NMI switch	Telco power alarm fault LED/Relay	ID switch	Telco critical alarm fault LED/Relay	Main power LED	Telco major alarm fault LED/Relay	HDD activity LED	Telco minor alarm fault LED/Relay	NIC activity LED		ID LED	
Power switch	Hard Drive 0 Fault LED																
Reset switch	Hard Drive 1 Fault LED																
NMI switch	Telco power alarm fault LED/Relay																
ID switch	Telco critical alarm fault LED/Relay																
Main power LED	Telco major alarm fault LED/Relay																
HDD activity LED	Telco minor alarm fault LED/Relay																
NIC activity LED																	
ID LED																	

2.2 Chapter Structure and Outline

This chapter is organized into the following sections. The content of each section is summarized as follows.

Section 2.3: Introduction

Provides an overview and block diagram of the Intel® Carrier Grade Server TIGPT1U.

Section 2.4: External Chassis Features

Describes features of the Intel® Carrier Grade Server TIGPT1U chassis in detail (buttons, switches, bezel, etc.).

Section 2.5: Internal Chassis Features

Provides an overview of the components of the Intel® Carrier Grade Server TIGPT1U.

Section 2.6: Server Management

Describes the server management features of the Intel® Carrier Grade Server TIGPT1U.

Section 2.7: Specifications

Summarizes the environmental and physical specifications of the Intel® Carrier Grade Server TIGPT1U.

2.3 Introduction

The Intel® TIGPT1U is a compact, high-density, rack mount server system with support for one Intel® Pentium® 4 Processor and 4 GB DDR266/DDR333/DDR400 unbuffered 184-pin DDR SDRAM DIMM memory. The Intel® TIGPT1U high availability features include hot swap disk drives and remote management. The scalable architecture of the Intel® TIGPT1U supports a variety of operating systems (OS).

Figure 2-1 shows an isometric view of the system.

Figure 2-2 shows the system with the top covers and the front bezel removed.

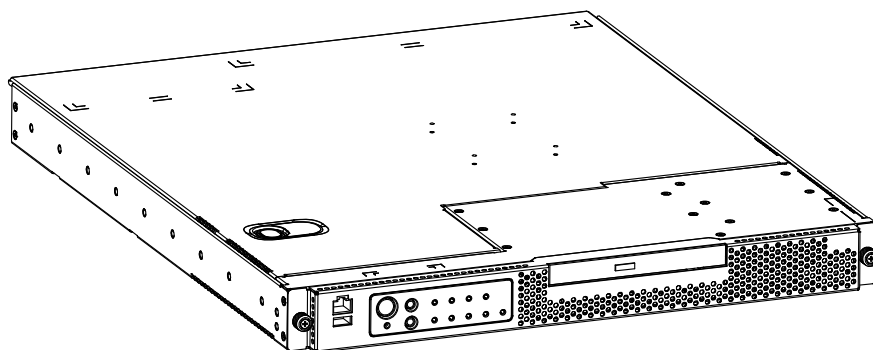

Figure 2-1. Intel® Carrier Grade Server TIGPT1U

The Intel® TIGPT1U uses the SE7210TP1-E system baseboard, which contains connectors for installing one Intel® Pentium® 4 Processor utilizing the uPGA478 socket. The baseboard has 4 DIMM slots and supports up to 4 GB error checking and correcting (ECC) unbuffered Synchronous Dynamic Random Access Memory (SDRAM). The SE7210TP1-E system baseboard also contains 1 PCI slots (implemented via riser cards), input/output (I/O) ports and various controllers.

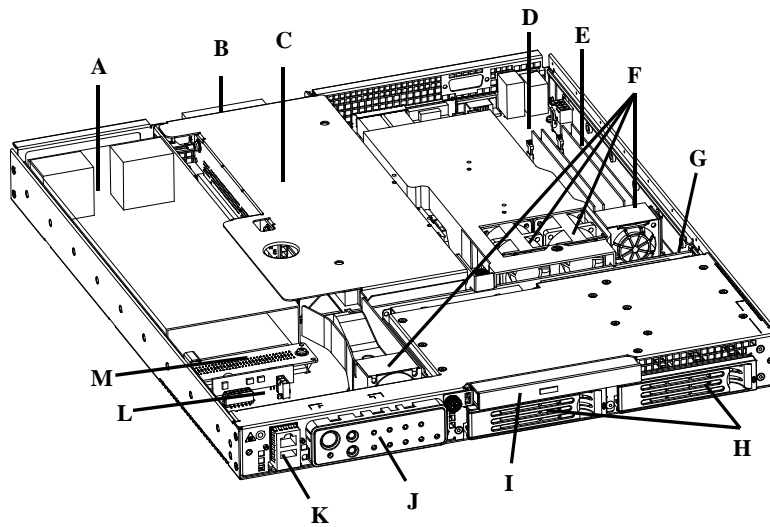

Figure 2-2. Intel® Carrier Grade Server TIGPT1U (shown with top covers and bezel removed)

A. Power Supply	H. SCSI Hard Disk Drive Bays
B. PCI card bracket (full-length)	I. Peripheral Bay (CDROM or DVD)
C. Riser card assembly (full-length)	J. Front Panel LEDs and Switches
D. SE7210TP1-E Server Baseboard	K. COM2/USB Front Panel Connector
E. System Memory	L. Extended Front Panel System Board
F. System Fans	M. Power Interconnect System Board
G. Midplane System Board	

The SE7210TP1-E system baseboard is mounted horizontally toward the rear of the chassis behind the system fan array.

Up to two 1.0” Ultra-320 SCSI technology hard drives can be mounted in the hot swap drive bays, which are located in the bottom front of the chassis. The front bezel needs to be removed to access the hot swap drive trays when installing or removing them from the hot swap drive bays.

Figure 2-2 shows the location of the two hot swap drive bays.

A slim-line CD-ROM drive can also be mounted in the system above the two hot swap drive bays.

System boards include the extended front panel board, the power supply interface board, and the SCSI hot swap backplane board. The extended front panel board is located in the front left of the chassis, the power supply interface board is located in the mid left of the chassis, and the SCSI hot swap backplane is located in the mid center and right of the chassis.

The 250 W power supply is mounted at the left-rear of the chassis. Two power supply options are available, one with AC-input and one with DC-input.

The system contains a fan array consisting of two 40 x 48 mm fans and one 40 x 28 mm fans to cool the SE7210TP1-E System Baseboard and other components. The fans are installed directly behind the drive bays and are located in front of the baseboard. Another 40 x 28 mm fan is located to the left of the hot swap drive bays and is used to cool the PCI adapter and left side of the SE7210TP1-E System Baseboard. Individual fan connectors are located on the system baseboard.

The front bezel can be customized to meet OEM industrial design requirements. The bezel design allows adequate airflow to cool the system components. The front bezel is removed to access the drive bay.

Figure 2-3 shows a block diagram of the Intel® Carrier Grade Server TIGPT1U with interconnections.

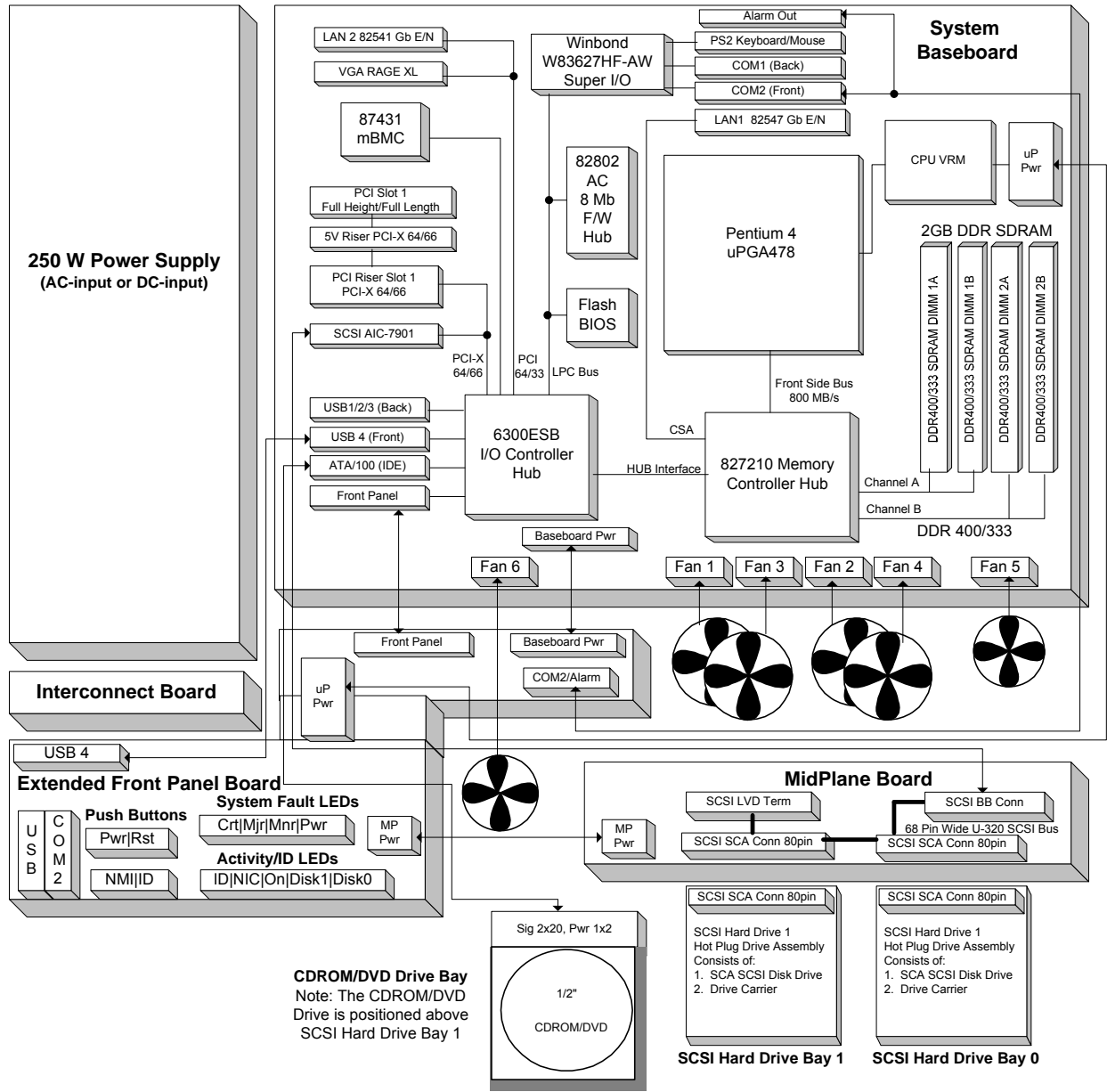

Figure 2-3. Intel® Carrier Grade Server TIGPT1U Block Diagram

2.4 External Chassis Features

2.4.1 Front View of Chassis

Figure 2-4 shows the front view of the system. Figure 2-5 shows the front view of the system with the front bezel removed. Removing the front bezel provides access to the two hot-plug hard drive bays.

Both areas are described in detail in the following sections.

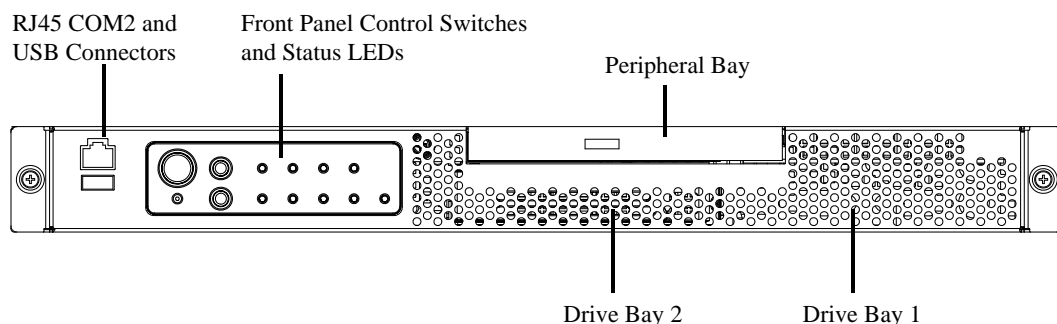

Figure 2-4. Front View of System

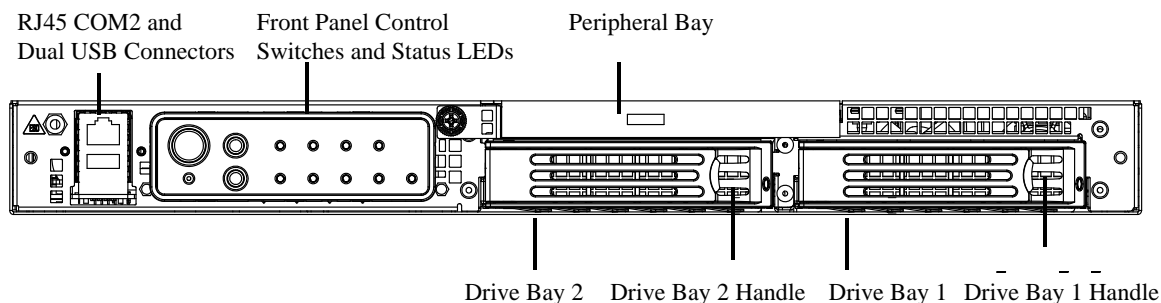

Figure 2-5. Front View of System (shown with bezel removed)

2.4.2 Front Panel

The front panel features are shown in Figure 2-6 and described in Table 2-2. All front panel control switches and status LEDs are contained on the front panel system board. Please refer to Section 5 Front Panel System Board for a detailed description of the control switches and status LEDs contained on the Front Panel.

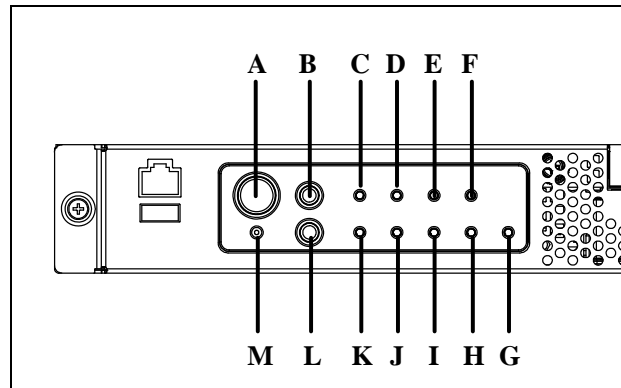

Figure 2-6. Front Panel Details

Table 2-2. Front Panel Features

Item	Feature	Description
Front Panel Switches		
A	Power switch	Toggles the system power
B	Reset switch	Resets the system
L	ID switch	Toggles system ID LED
M	NMI switch	Assert NMI to baseboard
Front Panel Alarm LEDs and Relays		
C	Critical (amber)	When continuously lit, indicates the presence of a Critical System Fault. A critical system fault is an error or event that is detected by the system with a fatal impact to the system. In this case, the system cannot continue to operate. An example could be the loss of a large section of memory, or other corruption, that renders the system not operational. The front panel critical alarm relay will be engaged.
D	Major (amber)	When continuously lit, indicates the presence of a Major System Fault. A major system fault is an error or event that is detected by the system that has discernable impact to system operation. In this case, the system can continue to operate but in a “degraded” fashion (reduced performance or loss of non-fatal feature reduction). An example could be the loss of one of two mirrored disks. The front panel major alarm relay will be engaged.
E	Minor (amber)	When continuously lit, indicates the presence of a Minor System Fault. A minor system fault is an error or event that is detected by the system but has little impact to actual system operation. An example would be a correctable ECC error. The front panel minor alarm relay will be engaged.
F	Power (amber)	When continuously lit, indicates the presence of a Power System Fault. The front panel power alarm relay will be engaged.
Front Panel Status LEDs		
G	Disk 1 Activity/Fault LED (green/amber)	Indicates disk 1 SCSI hard drive activity when green, or a disk 1 SCSI hard drive fault when amber
H	Disk 2 Activity/Fault LED (green/amber)	Indicates disk 2 SCSI hard drive activity when green, or a disk 2 SCSI hard drive fault when amber
I	Main power LED (green)	When continuously lit, indicates the presence of DC power in the server. The LED goes out when the power is turned off or the power source is disrupted.

Item	Feature	Description
J	NIC0/NIC1 activity LED (green)	Indicates activity on either NIC0 or NIC1
K	System ID LED (white)	Continuously lit when activated by (1) software command to extended front panel board or (2) by the front panel ID switch

2.4.3 Chassis Peripheral Bay and Hot-Plug SCSI Hard Drive Bays

The Intel® TIGPT1U server chassis provides two hot-swap SCSI hard drive bays at the front of the chassis, along with a peripheral bay that supports either a fixed CDROM Drive (read-only or read/write), or a fixed DVD Drive. Both hot-plug SCSI hard drive bays may be populated with a 3.5" SCSI Single Connector Attachment (SCA) hard disk drive mounted in a SCSI drive carrier.

The SCSI ID for each hard drive position is hardwired on the midplane board, so the use of jumper(s) to select a unique SCSI ID is not necessary. Hard disk drive position 1 is hardwired to SCSI ID 0 on the SCSI bus and hard disk drive position 2 is hardwired to SCSI ID 1 on the SCSI bus.

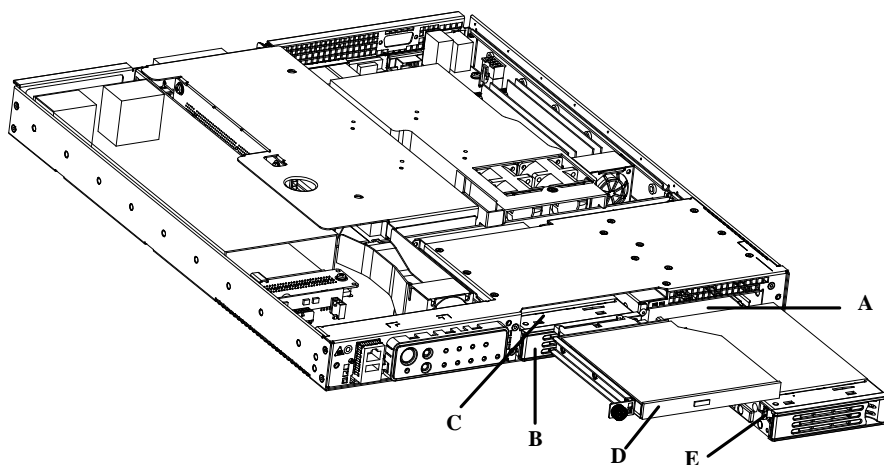

- A. Hard drive bay 1 (SCSI ID 0)
- B. Hard drive bay 2 (SCSI ID 1)
- C. Peripheral drive bay
- D. CD-ROM drive or DVD drive mounted in a peripheral carrier
- E. Hard disk drive module

Figure 2-7. Chassis Peripheral Bay and Hard Drive Bays

2.4.3.1 Peripheral Drive Bay

The peripheral bay supports either a CDROM drive or a DVD drive.

The peripheral drive carrier assembly can be configured with either a 0.5" (12.7 mm) slim-line CD-ROM or DVD drive. The install sequence is (1) slide the peripheral drive carrier into the peripheral drive bay, (2) tighten the thumb screw to secure the peripheral drive carrier to the chassis, and (3) connect the IDE and power cables to the interconnect board.

Note: A floppy drive cannot be installed in the system using the peripheral drive bay. If a floppy drive is needed, it will be necessary to use a Universal Serial Bus (USB) floppy and connect it to

the USB connection on the front of the unit or one of the USB connections on the back of the unit.

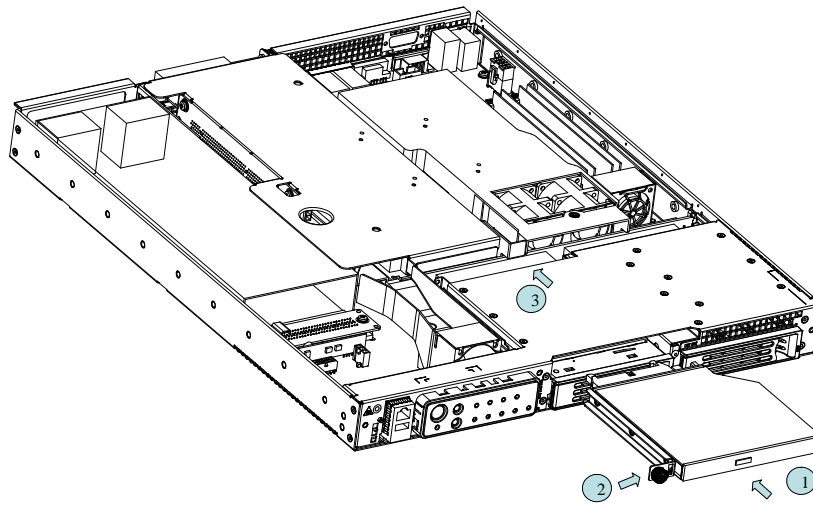
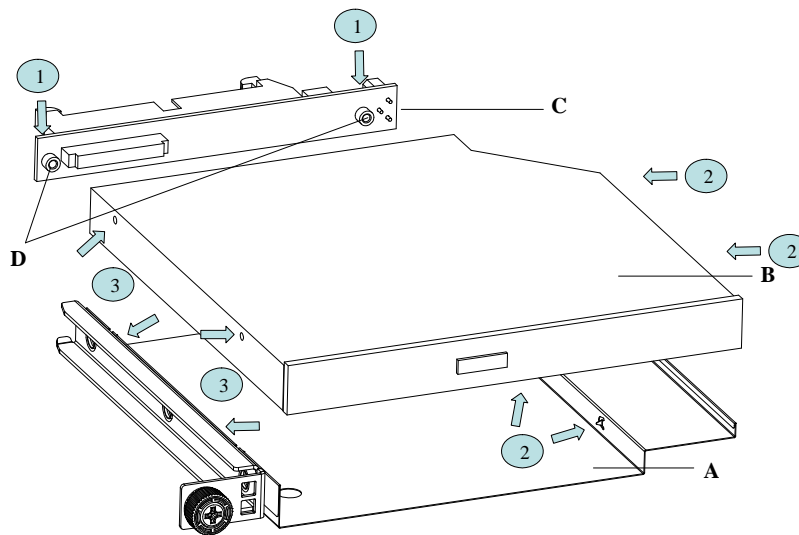

Figure 2-8. Peripheral Drive Bay

2.4.3.1.1 Peripheral Drive Carrier Assembly

The CDROM drive or DVD drive is installed in the drive carrier assembly before installing it into the system. An exploded view of the drive carrier assembly is shown in the following figure:



- A. Drive carrier metal housing
- B. CD-ROM or DVD Drive
- C. Interface Board
- D. Two screws to connect interface board to CD-ROM or DVD drive

Figure 2-9. Drive Carrier Assembly

Prior to installing the drive in the system, (1) the interface board is connected to the back of the drive and secured with two 8mm screws. The drive is then installed in the drive carrier metal housing by holding the left side of the drive carrier in the left hand, and with the right hand installing the right side of the drive into the right side of the drive carrier, (2) making sure to line up the two holes in the right side of the drive with the two mounting tabs on the right side of the drive carrier. Then, while flexing the left side of the drive carrier slightly down, (3) insert the left side of the drive into the drive carrier, making sure to line up the two holes on the left side of the drive with the two mounting tabs on the left side of the drive carrier. If this is done correctly, the drive carrier will be flush with the bottom and sides of the drive, and all four mounting tabs will be installed in the mounting holes on the drive. Observe that the right side mounting tabs are correctly inserted into the right side mounting holes on the drive by looking at the right bottom of the drive carrier assembly. Observe that the left side mounting tabs are correctly inserted into the left side mounting holes on the drive by looking at the top left of the drive carrier assembly.

2.4.3.2 Hard Drive Bays

There are two hot-plug SCSI SCA hard drive bays in the system (see (1) and (2) in the drawing below). Each hard drive bay supports a U320 SCA (single connector attach) SCSI disk drive mounted in a drive tray. The drive tray is installed into the front of the chassis in the hard drive bay, and then secured in place by latching the handle on the drive tray. Ultra 320 SCSI technology (SCA interconnect) or slower hard disk drives can be installed in the hard drive bays. The hard drive bays are designed to accept 15,000 rotations per minute (RPM) hard drives (and below) that consume up to 18 W of power.

The SCSI ID for each hard drive position is hardwired on the midplane board, so the use of jumper(s) to select a unique SCSI ID is not necessary. Hard disk drive position 1 is hardwired to SCSI ID 0 on the SCSI bus and hard disk drive position 2 is hardwired to SCSI ID 1 on the SCSI bus.

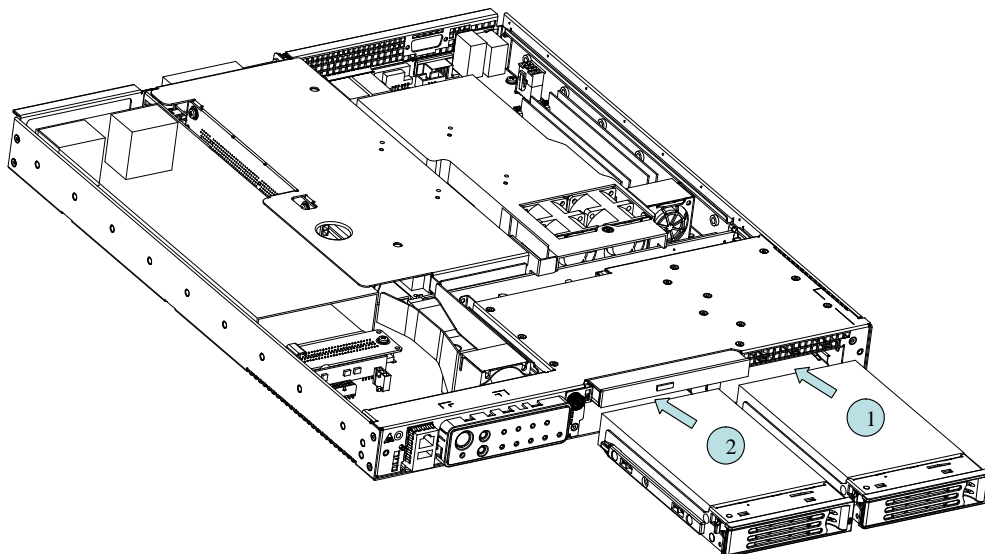

Figure 2-10. SCSI Hard Drive Bays

2.4.3.2.1 Hard Drive Tray

Each hard drive used in the system must be mounted to a drive tray using four screws inserted into the sides of the drive as shown in the figure.

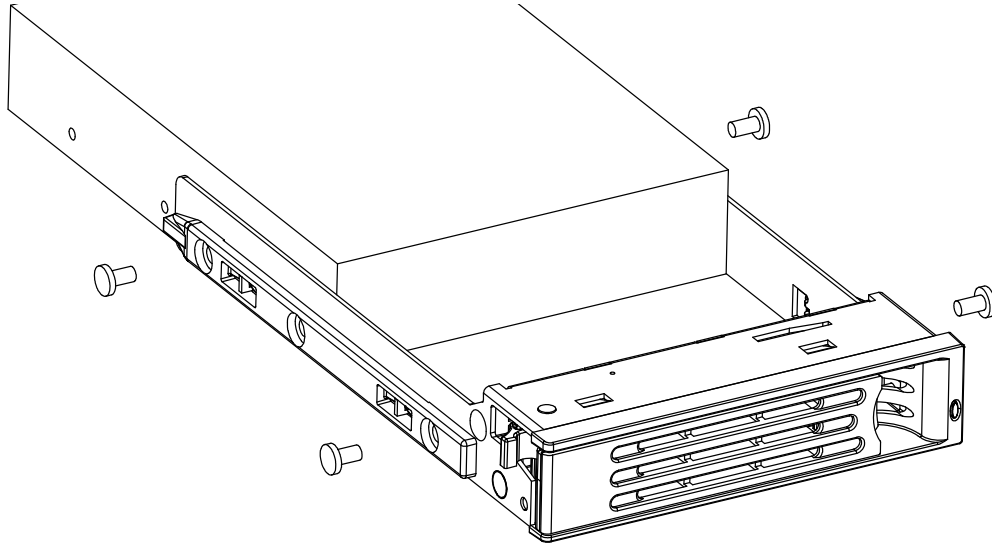

Figure 2-11. SCSI Hard Drive Carrier

2.4.4 Rear View of Chassis

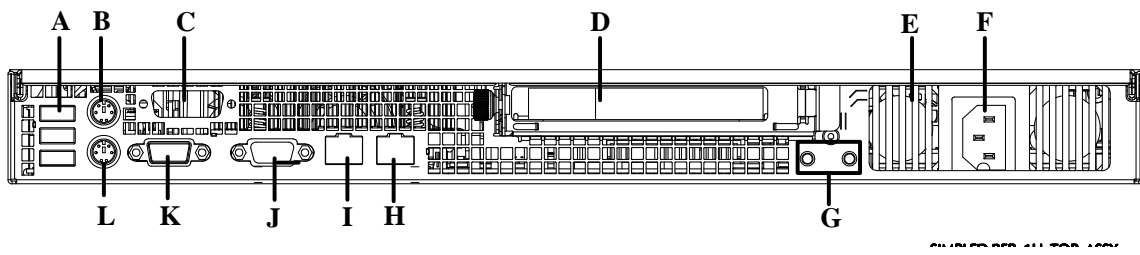

Figure 2-12. Rear View of System

Table 2-3. System Features - Rear

Item	Description
A	USB 1, USB 2, USB 3
B	PS/2 Mouse
C	DB15 Alarm Connector
D	PCI card bracket (full-height)
E	Power supply
F	AC power input (AC input power supply shown)
G	Ground Studs (used with system with DC input power supply)
H	RJ45 Network Interface Card (NIC) 2 connector
I	RJ45 NIC 1 connector
J	Video connector
K	DB9 serial 2 port
L	PS/2 Keyboard connector

2.5 Internal Chassis Features

2.5.1 Telecom SE7210TP1-E Server Baseboard

The telecom SE7210TP1-E Server Baseboard is a monolithic printed circuit board that can accept one Intel® Pentium® 4 Processor with hyper-threading technology in a μ PGA478 socket. The figure below shows the functional blocks of the telecom SE7210TP1-E Server Baseboard and the plug-in modules that it supports.

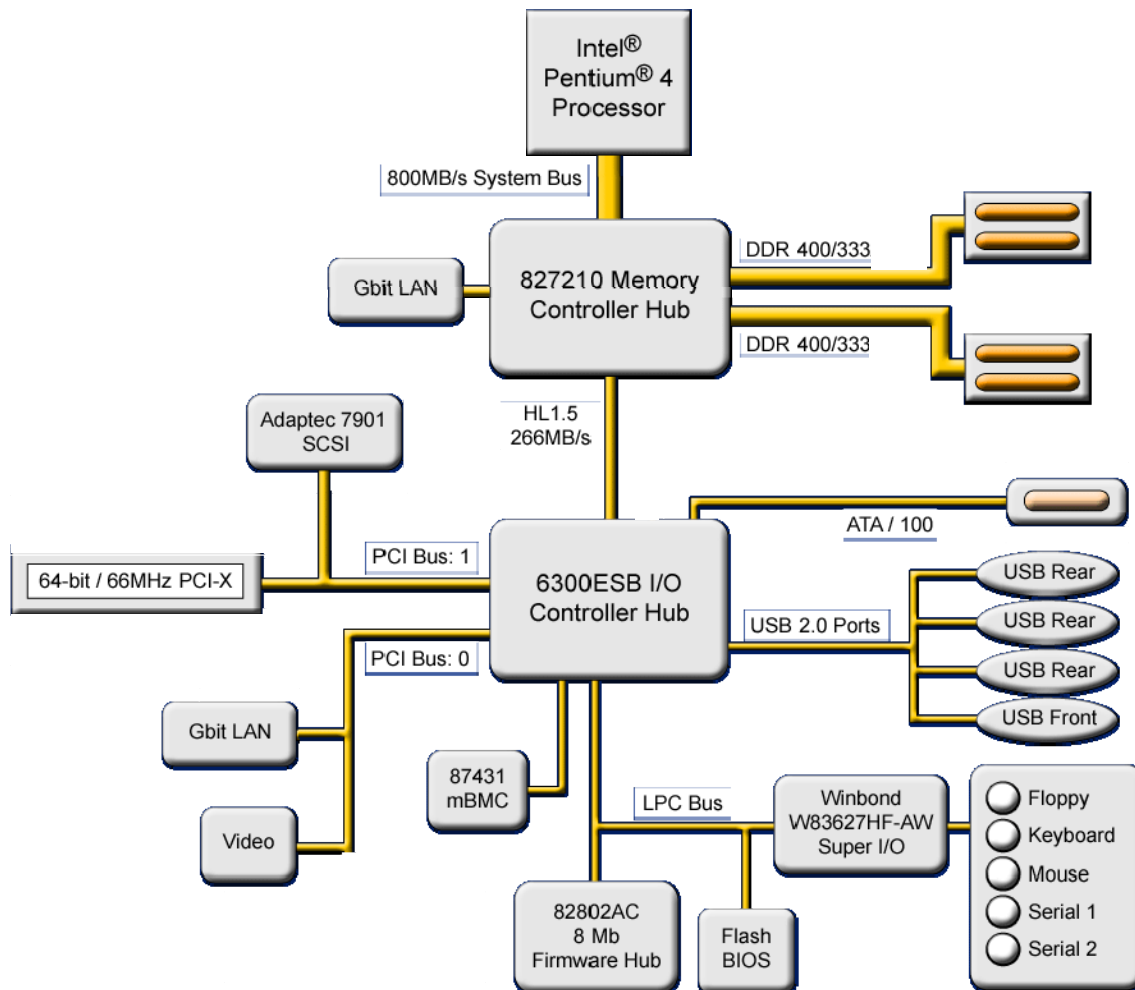

Figure 2-13. Telecom SE7210TP1-E Server Baseboard Block Diagram

- Support for an Intel® Pentium® 4 Processor with hyper-threading technology in a μ PGA478 socket (3.0 GHz frequency, 1 M L2 cache, 800 MHz Front Side Bus (FSB), 90 nm manufacturing technology).
- 400/533/800 MHz FSB
- Intel® E7210 chipset
 - Intel® 827210 Memory Controller Hub (MCH)
 - Intel® 6300ESB I/O Controller Hub (Hance Rapids)
 - Intel® 82802AC 8 Megabit Firmware Hub (FWH)

- Support for single-sided or double-sided dual inline memory module (DIMM) double-data rate (DDR) memory providing up to 4 GB of system memory with four 184-pin DIMM sockets
 - PC3200 (400 MHz): to run 400 MHz memory at full speed requires an Intel® Pentium® 4 Processor with 800 MHz system bus frequency.
 - PC2700 (333 MHz): to run 333 MHz memory at full speed requires an Intel® Pentium® 4 Processor with 533 MHz system bus frequency.

Note: PC2700 (333 MHz) memory will run at 320 MHz frequency when using an Intel® Pentium® 4 Processor with 800 MHz system bus frequency.
- Intel® 82547EI Platform LAN Connect (PLC) device for 10/100/1000 Mbps Ethernet LAN connectivity
- Intel® 82541EI device for 10/100/1000 Mbps Ethernet LAN connectivity
- Two independent PCI buses (one 32-bit, 33 MHz, 5 V; one 64-bit, 66 MHz, 3.3 V) with one PCI connectors and two embedded devices:
 - One PCI-X 64-bit 66-MHz PCI slots
 - Integrated 2D/3D graphics controller: ATI* Rage* XL Video Controller with 8 MB of SDRAM
 - Single channel, Ultra 320 Small Computer System Interface (SCSI) Controller: Adaptec* 7901*
- Low Pin Count (LPC) bus segment with one embedded device: Winbond* W83627HF-AW LPC Bus I/O controller chip providing all PC-compatible I/O (floppy, serial, keyboard and mouse)
- Three external USB 2.0 ports on the back panel with an additional internal header, which provides support for one additional USB port for front panel support (four total USB 2.0 ports)
- One serial port and one serial port header
- Two Integrated Drive Electronics (IDE) interfaces with Ultra 33, 66 and 100 Direct Memory Access (DMA) mode
- Support for up to six system fans
- Server System Infrastructure (SSI)-compliant connectors for SSI interface support: front panel, power connector
- Intel® Server Management 5.8 support via the National Semiconductor* PC87431M* Baseboard Management Controller (mBMC)

2.5.2 Full-Height, Full-Length PCI Adapter Subsystem

A one-slot PCI adapter assembly that supports one full-height/full-length PCI adapter is installed in the PCI riser slot located at the left side of the SE7210TP1-E System Baseboard. This PCI adapter assembly is configured and installed as shown in the following figure. After the PCI adapter assembly is removed from the system, it is configured with one PCI adapter by plugging the PCI adapter into the PCI connector on the riser card (either a 3.3 V riser card or a 5 V riser card) that is part of the PCI adapter assembly. The PCI adapter assembly is then installed into the system by plugging the riser card into the riser card connector on the SE7210TP1-E System Baseboard. Finally, the thumb screw located on the back of the server is secured to the PCI adapter assembly. Refer to the SE7210TP1-E System Baseboard specification for electrical characteristics for this PCI adapter subsystem. The maximum power supported for PCI adapters installed in the PCI Adapter subsystem is 25 watts.

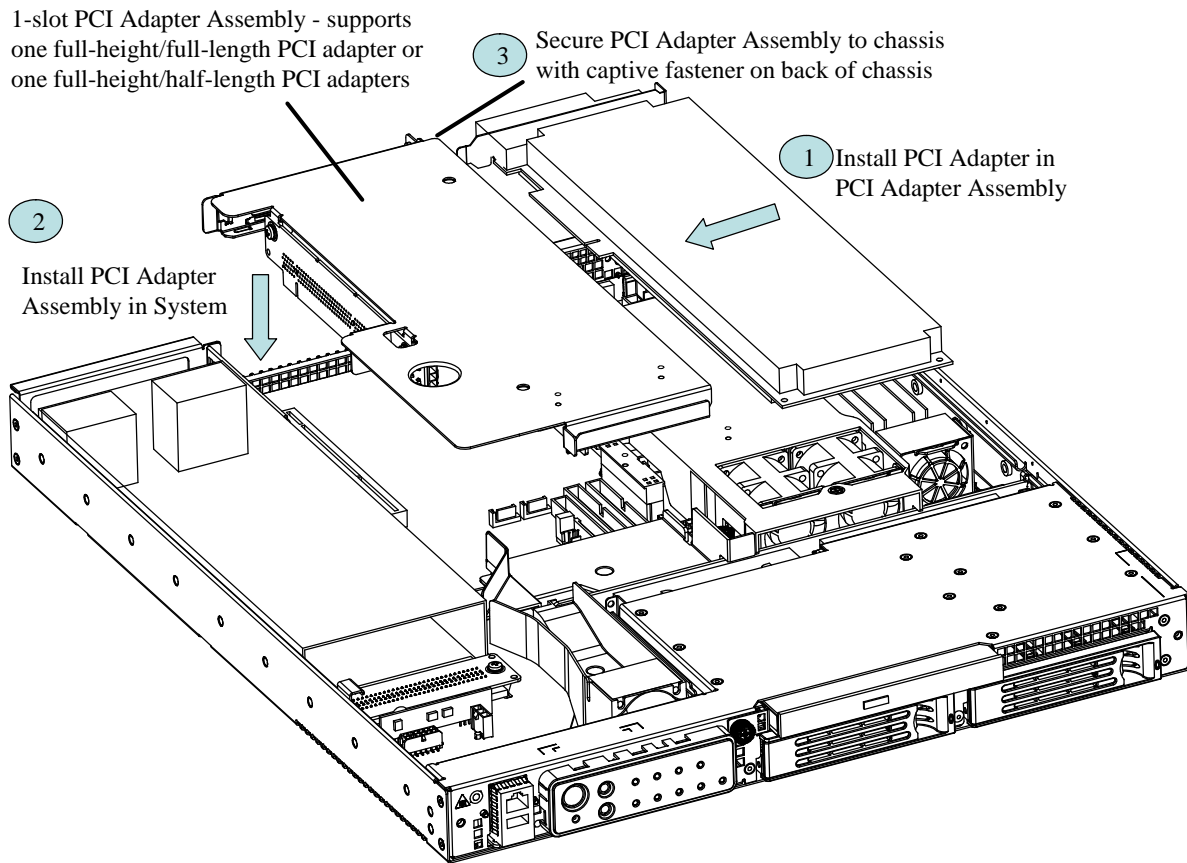

Figure 2-14. Full-Height, Full-Length PCI Adapter Subsystem

2.5.3 Power Subsystem

The Intel® Carrier Grade Server TIGPT1U can be configured with either a 250 watt AC-input power supply or a 250 watt DC-input power supply.

The 250 watt power supply interconnects to the power interface board with a board-edge connector. A board edge connector is also used by the extended front panel board to interconnect to the power interface board. Power is then carried to the 5 V riser board, the midplane board, and the system baseboard via discrete cables connected to individual connectors on the extended front panel board. The 250 watt power supply is capable of handling the worst-case power requirements for a fully configured Intel® Carrier Grade Server TIGPT1U. This includes one Intel® Pentium® 4 Processor, 4 GB of memory, two hard drives at 18 W per drive (typical worst case 3.5-inch by 1.0-inch, 15 k RPM drive), and one 25 watt PCI adapter.

2.5.4 Cooling Subsystem

2.5.4.1 Description

All system components except the power supply are cooled by two system fan assemblies. One fan assembly is mounted near the middle of the chassis, and a second fan assembly is mounted to the left of hard drive bay 1. These fan assemblies are shown in Figure 2-15.

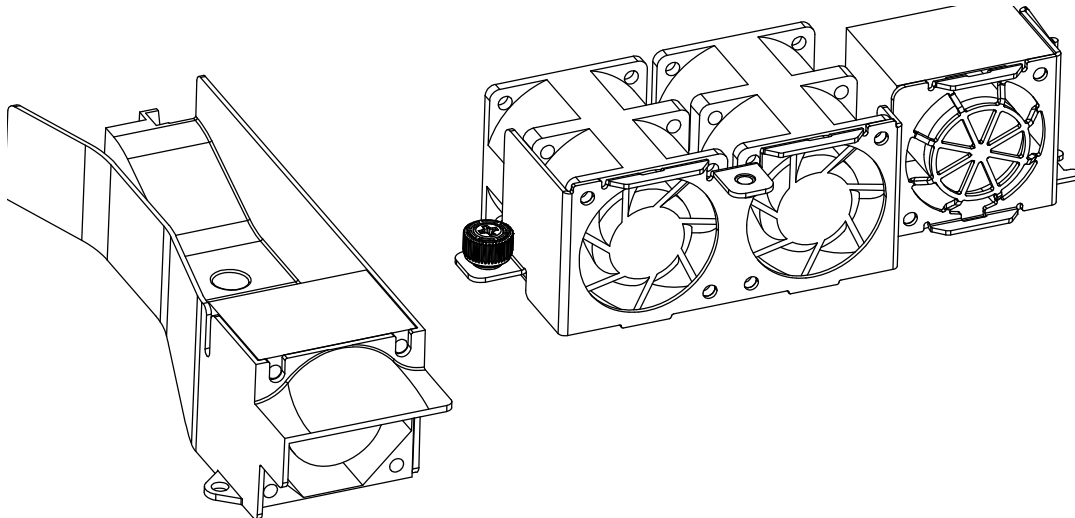

Figure 2-15. System Fan Assemblies

One fan assembly contains two 40 x 48 mm counter rotating fans that are used to cool the Intel® Pentium® 4 Processor, and also contains one 40 x 28 mm fan that is used to cool the DDR SDRAM memory and the processor Voltage Regulator Module (VRM) circuitry. Air to these fans comes in the front of the chassis and passes over the SCSI disk drives helping to provide cooling to the SCSI disk drives.

The other fan assembly contains one 40 x 28 mm fan that is used to cool the PCI adapter (maximum of 25 watts) as well as the components on the SE7210TP1-E System Baseboard that are located to the left of the Intel® Pentium® 4 Processor.

Each fan provides tachometer signal output to the SE7210TP1-E System Baseboard to indicate a fan failure.

2.5.4.2 Ambient Temperature Control

The SE7210TP1-E System Baseboard contains a pulse-width-modulation (PWM) circuit, which cycles the 12 Vdc fan voltage to provide quiet operation when system ambient temperature is low and there are no fan failures. Under normal room ambient conditions (less than 24° C) the fan power circuit supplies an effective fan voltage of 6.0 Vdc. When the room ambient temperature exceeds 24° C, the fan control circuit provides increased voltage levels to increase the speed of the fan. There are **sixteen** fan speed increments between 24° C and 40° C. At 40° C the fans operate at their maximum speed to provide maximum airflow.

2.5.4.3 Cooling Summary

The four-fan cooling subsystem is sized to provide cooling for:

- One Intel® Pentium® 4 Processor (3.0 GHz frequency, 1 M L2 cache, 800 MHz FSB, 90nm manufacturing technology)
- The SE7210TP1-E System Baseboard components
- 4 GB of SDRAM memory
- Two 15,000 RPM hard drives at a maximum of 18 watts per drive
- 1 PCI card at a maximum of 25 watts

The cooling subsystem is designed to meet acoustic and thermal requirements at the lower fan speed settings. At the higher fan speed settings, thermal requirements are met for the maximum ambient temperatures, but acoustic requirements are not met. The environmental specifications are summarized in 2.7.1.

2.6 Server Management

The Telco SE7210TP1-E Server Baseboard server management architecture features the National Semiconductor* PC87431M Baseboard Management Controller (mBMC), which autonomously monitors server status and provides the interface to server management control functions. This controller is responsible for controlling system power, resets, monitoring voltages, temperatures, fans, and communicating with secondary controllers on its Intelligent Platform Management Bus (IPMB).

The functions of the mBMC controller are summarized in the following section. The firmware for the National Semiconductor* PC87431M* (mBMC) is not intended to be field upgraded. Refer to the *System Server Management External Architecture Specification* for more details.

2.6.1 Baseboard Management Controller

The mBMC on the SE7210TP1-E System Baseboard provides server management monitoring capabilities. A flash memory is associated with the mBMC that holds the operational code, sensor data records (SDR), and system event log (SEL). There is also a serial Electrical Erasable Programmable Read Only Memory (EEPROM) that holds the mBMC configuration defaults and field replaceable unit (FRU) information. The various server management functions provided by the Bus Management Controller (BMC) are listed as follows:

- Baseboard voltage monitoring
- Fan failure detection
- Fan speed control
- Processor voltage monitoring
- Processor presence detection
- Processor internal error (IERR) monitoring
- Fault resilient booting (FRB)
- Watchdog timer
- Periodic system management interrupt (SMI) timer
- One I²C management bus interface for communicating with SIO and ADT7463
- System event log (SEL) management and access

- Sensor data record (SDR) repository management and access
- Processor nonmaskable interrupt (NMI) monitoring
- Processor System Management Interrupt (SMI) monitoring
- Time-stamp clock
- Secure mode and video blank
- Software front panel NMI generation

2.7 Specifications

2.7.1 Environmental Specifications

The Intel® TIGPT1U has been tested to the environmental specifications as indicated in Table 2-4. All testing was performed per procedures defined in Bellcore GR-63-CORE NEBS Physical Protection, Bellcore GR-3580 NEBS Criteria Levels, Bellcore GR-1089-CORE EMC and Electrical Safety – Generic Criteria for Network Telecommunications Equipment, and the *Intel® Environmental Standards Handbook*.

Table 2-4. Environmental Specifications Summary

Environment	Specification
Temperature operating	5° C to 40° C (41° F to 104° F)
Temperature nonoperating	-40° C to 70° C (-104° F to 158° F)
Altitude	0 to 1,800 m (0 to 5,905 ft)
Humidity nonoperating	95%, noncondensing at temperatures of 23° C (73° F) to 40° C (104° F)
Vibration operating	Swept sine survey at an acceleration amplitude of 0.1 g from 5 to 100 Hz and back to 5 Hz at a rate of 0.1 octave/minute, 90 minutes per axis on all three axes as per Bellcore GR-63-CORE standards
Vibration nonoperating	Swept sine survey at an acceleration amplitude of 0.5 g from 5 to 50 Hz at a rate of 0.1 octaves/minute, and an acceleration amplitude of 3.0 g from 50 to 500 Hz at a rate of 0.25 octaves/minute, on all three axes as per Bellcore GR-63-CORE standard. 2.2 Grms, 10 minutes per axis on all three axes as per the <i>Intel® Environmental Standards Handbook</i>
Shock operating	Half-sine 2 G, 11 ms pulse, 100 pulses in each direction, on each of the three axes as per the <i>Intel® Environmental Standards Handbook</i>
Shock nonoperating	Trapezoidal, 25 G, 170 inches/sec delta V, three drops in each direction, on each of the three axes as per <i>Intel® Environmental Standards Handbook</i>
Safety	UL 1950, CSA 950, IEC 950, TUV/GS EN60950
Emissions	Certified to FCC Class A; tested to CISPR 22 Class A, EN 55022 Class A, VCCI Class A ITE, AS/NZS 3548 Class A
Immunity	Verified to comply with EN 50082-1
Electrostatic discharge (ESD)	Tested to ESD levels up to 15 kilovolts (kV) air discharge and up to 8 kV contact discharge without physical damage as per <i>Intel® Environmental Standards Handbook</i>
Acoustic	Sound pressure: < 55 dBA at ambient temperatures < 24° C measured at bystander positions in operating mode

2.7.2 Physical Specifications

Table 2-5 describes the physical specifications of the Intel® TIGPT1U.

Table 2-5. Dimensions and Weight

Height	1.70 inches (43 mm)
Width	16.9 inches (430 mm)
Depth	20 inches (509 mm)
Front clearance	2 inches (76 mm)
Side clearance	1 inches (25 mm)
Rear clearance	3.6 inches (92 mm)
Weight of base system without: <ul style="list-style-type: none"> • Processor & heatsink • DIMMs • HDDs • PCI card 	20 lbs 0.0 oz
Weight of complete system Without: <ul style="list-style-type: none"> • PCI card 	25 lbs 6.3 oz
HDD (146GB SCSI)	01 lbs 10.6 oz
Processor 3.0GHz	00 lbs 0.7 oz
Heat sink for CPU	01 lbs 14.0 oz
DIMMs (Qty 4)	00 lbs 2.4 oz

3. Cables and Connectors

This chapter describes interconnections between the various components of the Intel® Carrier Grade Server TIGPT1U. In addition, this chapter includes an overview diagram of the Intel® TIGPT1U interconnections, as well as tables describing the signals and pin-outs for the connectors on the various system boards. Refer to the appropriate SE7210TP1-E System Baseboard section or system board sections in this document for other connector signal descriptions and pin-outs.

3.1 Chapter Structure and Outline

The information contained in this chapter is organized into four sections. The information is presented in a modular format, with numbered headings for each major topic and subtopic. The content of each section is summarized as follows:

- Section 3.2: Interconnect Block Diagram**
Provides an overview of system interconnects.
- Section 3.3: Cable and Interconnect Descriptions**
Provides a list of all the connectors and cables in the system.
- Section 3.4: User-accessible Interconnects**
Describes the form-factor and pin-out of user-accessible interconnects.

3.2 Interconnect Block Diagram

Figure 3-1 shows interconnections for all of the boards used in the Intel® TIGPT1U.

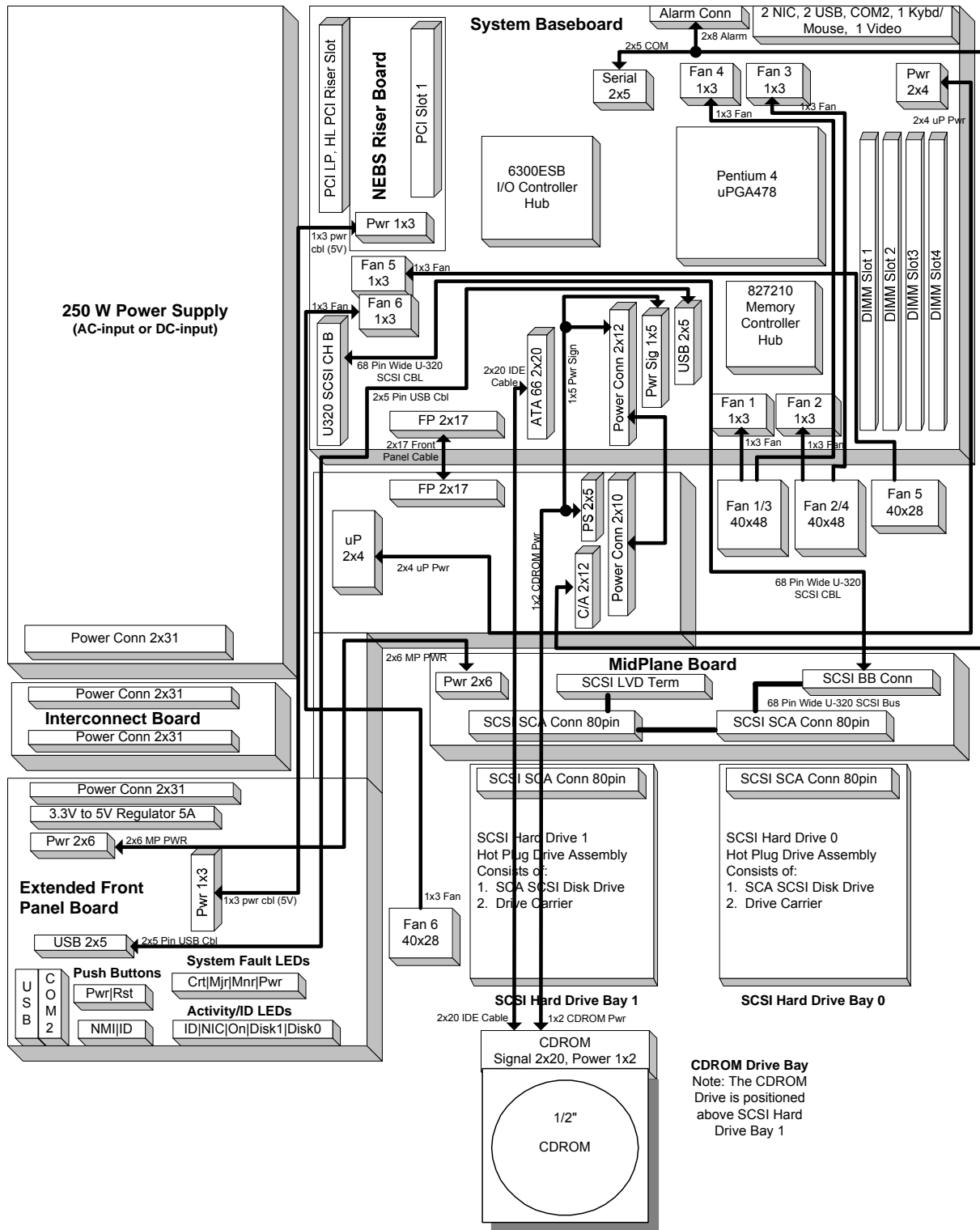

Figure 3-1. Intel® Carrier Grade Server TIGPT1U Interconnect Block Diagram

3.3 Cable and Interconnect Descriptions

Table 3-1 describes all cables and connectors of the Intel® Carrier Grade Server TIGPT1U.

Table 3-1. System Interconnect Descriptions

System Board	Ref Des	Connector Description	Cable/Device /Board	Ref Des	Connector Description
SE7210TP1-E Baseboard Connections					
Baseboard	J5G2	1 x 5 P/S Signal Connector	P/S Sig Cable	J5G2	1 x 5 P/S Signal Connector
Baseboard	J4J1	2 x 12 P/S Power Connector	P/S Pwr Cable	J4J1	2 x 12 P/S Power Conn
Baseboard	J9B1	2 x 4 uP Power Connector	P/S uP Pwr Cbl	J9B1	2 x 4 uP Power Connector
Baseboard	J4J2	2 x 20 IDE Connector	IDE Cable	J4J2	2 x 20 IDE Connector
Baseboard	J1J1	68 pin SCSI Ch B Conn	SCSI BB Cbl	J1J1	68 pin SCSI Connector
Baseboard	J8A2	2 x 5 Serial Port Connector	USB/Com2/Alrm	J8A2	2 x 5 Serial Port Connector
Baseboard	J5A1	1 x 3 Fan 1 Pwr/Tach Conn	40 x 48 Fan Right	J5A1	1 x 3 Fan Pwr/Tach Conn
Baseboard	J7A2	1 x 3 Fan 2 Pwr/Tach Conn	40 x 48 Fan Left	J7A2	1 x 3 Fan Pwr/Tach Conn
Baseboard	J7J3	1 x 3 Fan 3 Pwr/Tach Conn	40 x 48 Fan Right	J7J3	1 x 3 Fan Pwr/Tach Conn
Baseboard	J7J2	1 x 3 Fan 4 Pwr/Tach Conn	40 x 48 Fan Left	J7J2	1 x 3 Fan Pwr/Tach Conn
Baseboard	J1E2	1 x 3 Fan 5 Pwr/Tach Conn	40 x 28 Fan PCI	J1E2	1 x 3 Fan Pwr/Tach Conn
Baseboard	J1E1	1 x 3 Fan 5 Pwr/Tach Conn	40 x 28 Fan Mem	J1E1	1 x 3 Fan Pwr/Tach Conn
Baseboard	J3J2	2 x 17 Front Panel Conn	Front Panel (FP) Cable	J3J2	2 x 17 Front Panel Conn
Baseboard	J5G1	2 x 5 USB Connector	USB Cable	J5G1	2 x 5 USB Connector
Midplane Board Connections					
MP Board	J2L1	68 pin SCSI Connector	SCSI BB Cbl	J2L1	68 pin SCSI Connector
MP Board	J4A1	80 pin SCA Connector	SCSI Drive 1	J4A1	80 pin SCA Connector
MP Board	J8A1	80 pin SCA Connector	SCSI Drive 2	J8A1	80 pin SCA Connector
MP Board	J9L1	2 x 6 MP-FP Connector	MP-FP Cable	J9L1	2 x 6 MP-FP Connector
Extended Front Panel Board					
FP Board	J1E1	2 x 6 MP Power Conn	MP-FP Cable	J1E1	2 x 6 MP-FP Connector
FP Board	J3H1	1 x 3 Riser Power Conn	P/S CDRsr Cb	J3H1	1 x 3 Riser Power Conn
FP Board	J2G1	1 x 8 USB Connector	USB Cable	J2G1	1 x 8 USB Connector
FP Board	J5A1	2 x 4 uP Power Connector	P/S uP Pwr Cbl	J5A1	2 x 4 uP Power Connector
FP Board	J8A1	2 x 17 Front Panel Conn	FP Cable	J8A1	2 x 17 Front Panel Conn
FP Board	J9B1	2 x 12 COM2/Alarm Conn	C2/Alarm Cbl	J9B1	2 x 12 COM2/Alarm Conn
FP Board	J9A1	2 x 5 PS Sig/Pwr Conn	PS Sig/Pwr Cbl	J9A1	2 x 5 PS Sig/Pwr Conn
FP Board	J10A1	2 x 10 PS Pwr Conn	PS Pwr Cable	J10A1	2 x 10 PS Pwr Conn
FP Board	J1J1	RJ45 COM2/ USB con	N/C		

CDROM Interface Board Connections					
CDROM I/F	P1	2 x 1 Power Connector	CDROM Pwr Cb	P1	2 x 1 Power Connector
CDROM I/F	P3	2 x 20 IDE Connector	IDE Cable	P3	2 x 20 IDE Connector
NEBS Riser Board Connections					
NEBS Rsr	J1A1	1 x 3 Power Connector	P/S CDRsr Cb	J1A1	1 x 3 Power Connector

3.4 Exteranly-Accessible Interconnects

3.4.1 Keyboard and Mouse Ports

PS/2 keyboard and mouse connectors are located on the back panel. The +5 V lines to these connectors are protected with a PolySwitch* circuit that, like a self-healing fuse, reestablishes the connection after an overcurrent condition is removed.



NOTE

The keyboard is supported in the bottom PS/2 connector and the mouse is supported in the top PS/2 connector. Power to the server should be turned off before a keyboard or mouse is connected or disconnected.

The keyboard controller contains the AMI keyboard and mouse controller code, provides the keyboard and mouse control functions, and supports password protection for power-on/reset. A power-on/reset password can be specified in the BIOS Setup program.

Table 3-2. Keyboard/Mouse PS/2 Connector Pin Out (J9A1)

Connector	Pin	Signal Name
Keyboard	1	Data
	2	NC
	3	GND
	4	+5 V (Fused)
	5	Clock
	6	NC
Mouse	7	Data
	8	NC
	9	GND
	10	+5 V (Fused)
	11	Clock
	12	NC
	13	NC
	14	NC
	15	NC
	16	NC
	17	NC

3.4.2 Serial Ports

The Intel® Server Board SE7210TP1-E has one 9-pin D-sub serial port connector for COM1 and one 2 x 5 serial port connector COM2. COM2 is brought out the front of the chassis by an RJ45 connector. by cabling between the 2 x 5 serial port connector on the Intel® Server Board SE7210TP1-E and a mating connector on the extended front panel board. The following tables detail the pin outs of these two ports.

Table 3-3. COM1: 9-pin Serial A Port Pin Out (J8A1)

Pin	Signal
1	DCD (Data Carrier Detect)
2	RXD (Receive Data)
3	TXD (Transmit Data)
4	DTR (Data Terminal Ready)
5	GND
6	DSR (Data Set Ready)
7	RTS (Request to Send)
8	CTS (Clear to Send)
9	RI (Ring Indicator)

The front panel board has provision for the COM2 port using a RJ45 connector. This RJ45 connector is accessible at the front of the system.

Table 3-4. COM2: Serial Port Connector on Front Panel

Pin	Signal
1	RTS (request to send)
2	DTR (data terminal ready)
3	TXD (transmit data)
4	GND
5	RIA (ring indicator)
6	RXD (receive data)
7	DSR/DCD (date set ready / data carrier detect ¹)
8	CTS (clear to send)

¹ Use jumper on extended front panel board to select

3.4.3 Video Port

The video port interface is a standard VGA compatible, 15-pin connector. Onboard video is supplied by an ATI* Rage* XL video controller with 8 MB of onboard video SGRAM.

Table 3-5. Video Connector

Pin	Signal
1	Red (analog color signal R)
2	Green (analog color signal G)
3	Blue (analog color signal B)
4	No connection
5	GND
6	GND
7	GND
8	GND
9	Fused VCC (+5 V)
10	GND
11	No connection
12	V_MONID1
13	HSYNC (horizontal sync)
14	VSYNC (vertical sync)
15	V_MONID2

3.4.4 Universal Serial Bus (USB) Interface

The baseboard provides four USB ports. USB ports 1, 2, and 3 are brought out the rear of the unit on the baseboard, and USB port 4 is brought out the front of the unit on the extended front panel. The front USB port is accessible without removing the front bezel. The built-in USB ports permit the direct connection of four USB peripherals without an external hub. If more devices are required, an external hub can be connected to any of the built-in ports.

Table 3-6. Single USB Connector

Pin	Signal
1	Fused VCC (+5 V w/over-current monitor of ports 0, 1, 2, and 3)
2	DATAL0 (differential data line paired with DATAH0)
3	DATAH0 (differential data line paired with DATAL0)
4	GND
5	GND
6	GND

3.4.5 Ethernet Connector

The server board SE7210TP1-E supports two NIC RJ45 connectors for the Ethernet ports. The following table details the pin-out of each of the connectors.

Table 3-7. Magjack Connector (RJ45, 10/100/1000) Pin Out (J5A1, J6A2)

Pin	Signal Name	Pin	Signal Name
1	LAN_V_1P8	10	LAN_MDI_0*
2	LAN_MDI_2*	11	LAN_MDI_0
3	LAN_MDI_2	12	LAN_V_1P8
4	LAN_MDI_1	13	LAN_LINK_100*
5	LAN_MDI_1*	14	LAN_LINK
6	LAN_V_1P8	15	LAN_LINK_UP*
7	LAN_V_1P8	16	LAN_ACTLED*
8	LAN_MDI_3	17	GND
9	LAN_MDI_3*	18	GND

3.4.6 Telco Alarms Connector

The system provides one telco DB15 alarms connector on the rear bulkhead. Table 3-8 shows the pinout for the telco alarms connector, and Figure 3-2 shows the telco alarms connector as viewed from the back of the server.

Table 3-8. Telco Alarms Connector

Pin	Description	Pin	Description
1	MinorReset +	9	MinorAlarm – NC
2	MinorReset -	10	MinorAlarm - COM
3	MajorReset +	11	MajorAlarm - NO
4	MajorReset -	12	MajorAlarm - NC
5	CriticalAlarm - NO	13	MajorAlarm - COM
6	CriticalAlarm - NC	14	PwrAlarm - NO
7	CriticalAlarm - COM	15	PwrAlarm - COM
8	MinorAlarm - NO		

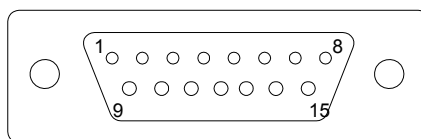

Figure 3-2. Telco Alarms Connector

3.4.7 AC Power Input for AC-Input Power Supply

One IEC320-C13 receptacle is provided at the rear of the AC-input power supply. It is recommended to use an appropriately sized power cord and AC main. Please refer to *Section 9, AC Power Subsystem*, in this document for system voltage, frequency, and current draw specifications.

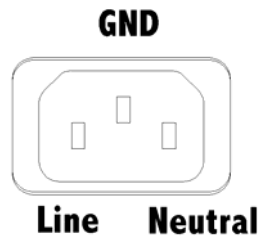

Figure 3-3. AC Power Input Connector

3.4.8 DC Power Input for DC-Input Power Supply

A DC power terminal block is provided at the rear of the DC-input power supply. It is recommended to use appropriately sized power wire and DC main.

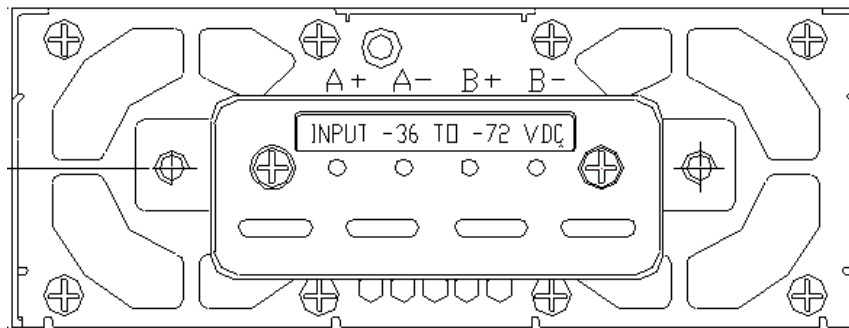

Figure 3-4. DC Power Input Connector

The terminal block will accept standard terminal lugs size Newark stock # 81N1501 type CRS-T0-1406-HT that accept 14 AWG wire gauge. The width (w , see Figure 2-1) of the lug can be no larger than 0.25 inches.



Figure 3-5. Terminal Lug

4. Extended Front Panel System Board

This chapter describes the basic functions and interface requirements of the Extended Front Panel system board that is designed for the Intel® Carrier Grade Server TIGPT1U.

4.1 Features

- Four switches to control power-on, reset, NMI, and the system ID LED
- One system ID LED that can be controlled remotely or by the system ID switch
- Two system activity LEDs that indicate power-on and NIC activity
- Two hard drive activity/fault LEDs that indicate activity/fault status for drives 0 and 1
- Four system fault LEDs that indicate critical, major, minor, and power system fault status
- Four system fault relays for external critical, major, minor, and power fault indicators
- Hot-swap circuitry for controlling power delivery to SCSI disk drives 0 and 1
- Power distribution to SE7210TP1-E System Baseboard, drive carrier assemblies, and hot plug disk drives 1 and 2

4.2 Chapter Structure and Outline

The information contained in this chapter is organized into eight sections. The information is presented in a modular format, with numbered headings for each major topic and subtopic. The content of each section is summarized as follows:

Section 4.3: Introduction

Provides an overview of the Intel® TIGPT1U extended front panel board, showing primary components and their relationships, and physical board layout diagrams.

Section 4.4: Functional Description of Front Panel Switches, LEDs, and Relays

Provides a functional description of the front panel switches, LEDs, and relays contained on the FPIO board.

Section 4.5: Connector Information

Provides information on all connectors contained on the extended front panel board. Gives signal descriptions and the corresponding electrical parameters for each input and output of a given connector.

Section 4.6: SCSI Power Subsystem

Provides information on the hard drive interface circuitry on the extended front panel board. The hard drive interface circuitry is designed to give the end user support for two SCSI hot-plug hard drives. The design enables easy use and replacement of the SCSI hard drives without powering down the system.

Section 4.7: Specifications

Describes the electrical, environmental and mechanical specifications.

4.3 Introduction

The extended front panel system board provides the means of mounting and electrically connecting switches and indicators for system operation and status. These features are accessible and visible from the front of the chassis. In addition, it contains the hard drive hot-plug control circuitry necessary for the hot-plug SCSI disk drives. An alarms function is also provided. The extended front panel system board is designed for use with telecom SE7210TP1-E Server Baseboards.

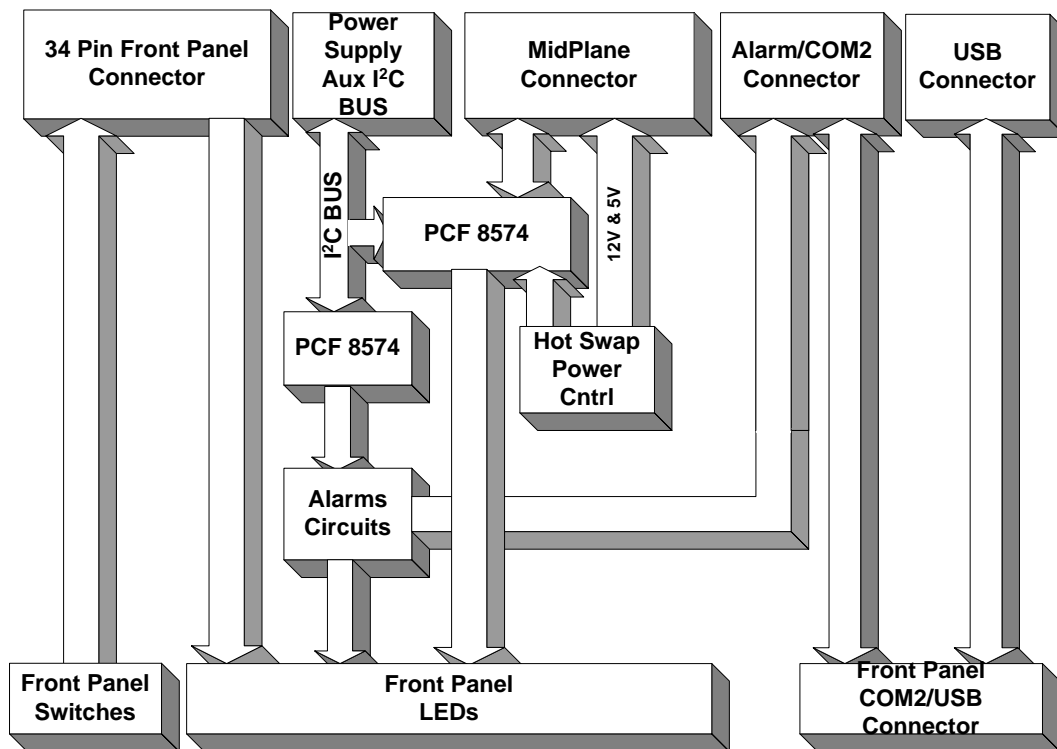

Figure 4-1. Extended Front Panel Board

4.4 Functional Description of Front Panel Switches, LEDs, and Relays

4.4.1 Front Panel Switches

The front panel has a power switch, a reset switch, an NMI switch, and a system ID switch. The function of each switch is described in the following table.

Table 4-1. Front Panel Switch Description

Switch	Function
Power Switch	A momentary switch, APCI compliant, used to toggle system power on/off.
Reset Switch	A momentary switch used to reset the system when it is in the power-on state.
NMI Switch	A momentary switch used to instruct the processor to copy system memory to hard disk
System ID Switch	A momentary switch used to instruct the processor to toggle the state of the system ID LED

4.4.2 Front Panel LEDs

Table 4-2. LED Specifications

LED Function	LED Color	Peak Wavelength (nm)	Luminous Intensity Typ(mcd)	Luminous Intensity Min(mcd)
ID	White	N/A	50	36
	Blue	470	50	18
NIC	Green	560	12	6
ON	Green	560	12	6
DRV 1/0 Activity	Green	568	12	2.6
DRV 1/0	Red	625	12	4.0
CRT	Red	660	23	6
	Yellow-Green	570	16.8	6
MJR	Red	660	23	6
	Yellow-Green	570	16.8	6
MNR	Yellow	580	5.9	3
PWR	Yellow	580	5.9	3

4.4.3 System Status LEDs

There are five extended front panel system board system status LEDs. The function of these system status LEDs is described in the following table.

Table 4-3. Front Panel System Status LED Description

Status LED	Function
Power	The green <i>Power LED</i> indicates that system power is on when it is illuminated continuously. When it is blinking green, it indicates that the system is in ACPI sleep mode.
NIC0/NIC1	The green <i>NIC activity LED</i> indicates network link presence and activity on either NIC0 or NIC1
System ID	The white or blue <i>NIC activity LED</i> is used to identify a particular system. The LED can be toggled remotely or with the System ID Switch
Disk 0	The <i>green/amber/red hard drive 1 activity/fault LED</i> displays activity or fault status for hard disk drive 1
Disk 1	The <i>green/amber/red hard drive 2 activity/fault LED</i> displays activity or fault status for hard disk drive 2

4.4.4 System Fault LEDs

There are four front panel system fault LEDs. The function of these system fault LEDs is described in the following table.

Table 4-4. Front Panel System Fault LED Description

Fault LED	Function
Critical	This amber or red LED alarm is illuminated via the Server Management Bus (SMBus) and may only be turned off via SMBUS control. When continuously lit, it indicates the presence of a Critical System Fault. A critical system fault is an error or event that is detected by the system with a fatal impact to the system. In this case, the system cannot continue to operate. An example could be the loss of a large section of memory, or other corruption, that renders the system not operational. The front panel critical alarm relay will be engaged.
Major	This amber or red major alarm is illuminated via SMBUS bus and may be turned off via SMBUS control or alarm connector reset. When continuously lit, it indicates the presence of a Major System Fault. A major system fault is an error or event that is detected by the system that has discernable impact to system operation. In this case, the system can continue to operate, but in a “degraded” fashion (reduced performance or loss of non-fatal feature reduction). An example could be the loss of one of two mirrored disks. The front panel major alarm relay will be engaged.
Minor	This amber LED minor alarm is illuminated via SMBUS bus and may be turned off via SMBUS control or alarm connector reset. When continuously lit, it indicates the presence of a Minor System Fault. A minor system fault is an error or event that is detected by the system but has little impact to actual system operation. An example would be a correctable ECC error. The front panel minor alarm relay will be engaged.
Power	The amber power alarm is illuminated via SMBUS bus or SYS_FLT_LED_L signal and may only be turned off via SMBUS control. When continuously lit, it indicates the presence of a Power System Fault. The front panel power alarm relay will be engaged.

4.4.5 LED Color Selection

The Extended Front Panel Board (XFPB) supports population options for two different SKUs, the Intel® SKU and an OEM SKU. The Intel® SKU supports a white ID LED and amber HDD fault LEDs. The OEM SKU supports a blue ID LED and red hard disk drive (HDD) fault LEDs. Selecting between the two SKUs are done during board build. For an Intel® SKU, install a white LED at location DS4J2 and install n-FETs at locations Q5W6 and Q5W2. For an OEM SKU, install a blue LED at location DS4J2 and remove n-FETs at locations Q5W6 and Q5W2. LED color selection to support the Intel® SKU and OEM SKU are outlined in the following table:

Table 4-5. LED Color Selection

Board SKU	LED Color	Board Location Reference Designator	Board Population Option
OEM	ID Blue	DS4J2	Install iPN 697565-010
Intel	ID White	DS4J2	Install iPN 697565-009
OEM	Disk 0 Fault Red	Q5W6	Remove component
Intel	Disk 0 Fault Amber	Q5W6	Install component
OEM	Disk 1 Fault Red	Q5W2	Remove component
Intel	Disk 1 Fault Amber	Q5W2	Install component

4.4.6 System Fault Relays

The front panel board contains four relays. These relays are for power, critical, major and minor alarms. The relays are controlled via the SMBus. See Section 4.4.7 for programming information.

4.4.7 Server Management Bus (SMBus) Interface

The Torrey Pines baseboard communicates to the XFPB via the auxiliary I²C bus to support server management functions. The I²C interface operates at less than 20 KHz rate to support SMBus functionality. Two I/O expanders on the XFPB are used as slave devices to interface to the SMBus.

The first device (U3H1) is used to support the control and monitoring of the front panel alarms. All signals at U3H1 that interface to the alarms circuitry are active low. During power up, the device will reset all I/Os to the default High state. However, during system soft resets, the device requires a software command to reinitialize all I/Os to the default inactive state.

Access to U3H1 during a write cycle can be performed by writing to address 0 x 40. Access to U3H1 during a read cycle can be performed by writing to address 0 x 41. Refer to Table 4-6 for an I/O map of U3H1.

The second device (U2H1) is used to support the control and monitoring of the two SCSI hard drives. Also, during a drive fault condition, U2H1 receives commands from the baseboard to activate the proper drive fault LED to provide visual indications of a fault condition. All signals at U2H1 that interface to the SCSI control circuitry are active low. During power up, the device will reset all I/Os to the default High state. However, during system soft resets, the device requires a software command to reinitialize all I/Os to the default inactive state.

Access to U2H1 during a write cycle can be performed by writing to address 0 x 44. Access to U2H1 during a read cycle can be performed by writing to address 0 x 45. Refer to Table 4-7 for an I/O map of U2H1.

Table 4-6. Alarms SMBus I/O Mapping

Bit	I/O	Name	Description
0	O	Power alarm	Writing 0 turns on the power alarm relay and illuminates the POWER LED, writing 1 turns both off. The relay and LED may also be turned on by a FAN_FAIL_L signal.
1	O	Critical alarm	Writing 0 turns on the critical alarm relay and illuminates the CRITICAL LED, writing 1 turns both off.
2	O	Major alarm	Writing a 1 to 0 edge will turn on the flip-flip that enables major alarm relay. Writing a 1 will turn off the major alarm relay or a MAJOR_RESET signal input. MAJOR LED in on when output is 0, off when output is 1.
3	O	Minor alarm	Writing a 1 to 0 edge will turn on the flip-flip that enables major alarm relay. Writing a 1 will turn off the major alarm relay or a MINOR_RESET signal input. MINOR LED in on when output is 0, off when output is 1.
4	I	Major alarm sense	Senses the state of the major alarm relay. 0 relay is on, 1 relay is off. This allows software to detect if the MAJOR_RESET signal was activated. Always write 1 during write operations.
5	I	Minor alarm sense	Senses the state of the minor alarm relay. 0 relay is on, 1 relay is off. This allows software to detect if the MINOR_RESET signal was activated. Always write 1 during write operations.

Bit	I/O	Name	Description
6	I	Critical/Major color	Writing a 1 turns CRITICAL and MAJOR LEDs to yellow, writing 0 color is RED. Strapping J7D1 pins 7-8 forces LEDs to RED. Resets to yellow.
7	I	Not used	Reserved for future use, always write 1 during write operations.

¹ Normally closed (NC) and normally open (NO) relay contacts are provided on the rear panel Telco alarms connector. To activate the relay, a 1 to 0 transition must be written.

Table 4-7. SCSI SMBus I/O Mapping

Bit	I/O	Name	Description
0	O	SCSI1_LED_FLT_N	Writing 0 to this signal will activate the SCSI drive fault circuitry and illuminate the SCSI1 fault LED.
1	O	SCSI0_LED_FLT_N	Writing 0 to this signal will activate the SCSI drive fault circuitry and illuminate the SCSI0 fault LED.
2	O	SCSI1_INSERTED_N	This signal provides a future use option to allow server management to control activation of the SCSI1 drive power delivery circuitry. Writing 0 to this signal will enable the hot swap circuitry to power on. However, the signal is set to the disabled mode in the current board configuration.
3	O	SCSI0_INSERTED_N	This signal provides a future use option to allow server management to control activation of the SCSI1 drive power delivery circuitry. Writing 0 to this signal will enable the hot swap circuitry to power on. However, the signal is set to the disabled mode in the current board configuration.
4	I	SCSI1_MATED_N	This signal senses drive presence at SCSI drive slot 1. A low state at this signal indicates that a drive is populated at slot 1
5	I	SCSI0_MATED_N	This signal senses drive presence at SCSI drive slot 0. A low state at this signal indicates that a drive is populated at slot 0
6	I	SCSI_PWRGOOD1	This signal senses the state of the SCSI drive 1 hot swap controller. A low state at this signal indicates that no power is delivered to drive 1.
7	I	SCSI_PWRGOOD0	This signal senses the state of the SCSI drive 1 hot swap controller. A low state at this signal indicates that no power is delivered to drive 1.

4.5 Connector Information

The following tables show all the connectors on the XFPB and the interconnection to other devices within the Intel® TIGPT1U. In addition, the first column references the location on the following figure of the connector location.

Table 4-8. Extended Front Panel System Board Connector Information

FPIO Board Connections				
Loc	Ref Des	Function	Interconnect	Connects to
1	J2G1	1 x 8 USB Connector	USB Cable	Baseboard USB Connector
2	J5A1	2 x 4 Processor Power Conn	uP Pwr Cable	Baseboard uP Power Connector
3	J8A1	2 x 17 Front Panel Conn	FP Cable	Baseboard Front Panel Connector
10	J1E1	2 x 6 Midplane Pwr/Sig	MP Cable	Midplane Power/Signal Connector
11	J9A1	2 x 5 Power Conn	Pwr/Sig Cable	Baseboard Power/Signal Connector
12	J9B1	2 x 12 Alarm/COM2 Conn	Alarm/Com Cbl	Baseboard COM2/Chassis Alarm
13	J10A1	2 x 10 Power Connector	Power Cable	Baseboard Power Connector
14	J1J1	RJ45 COM2/USB Conn	N/C	
16	J3H1	1 x 3 NEBS Riser Pwr Conn	Riser Pwr Cbl	NEBS Riser Power Connector

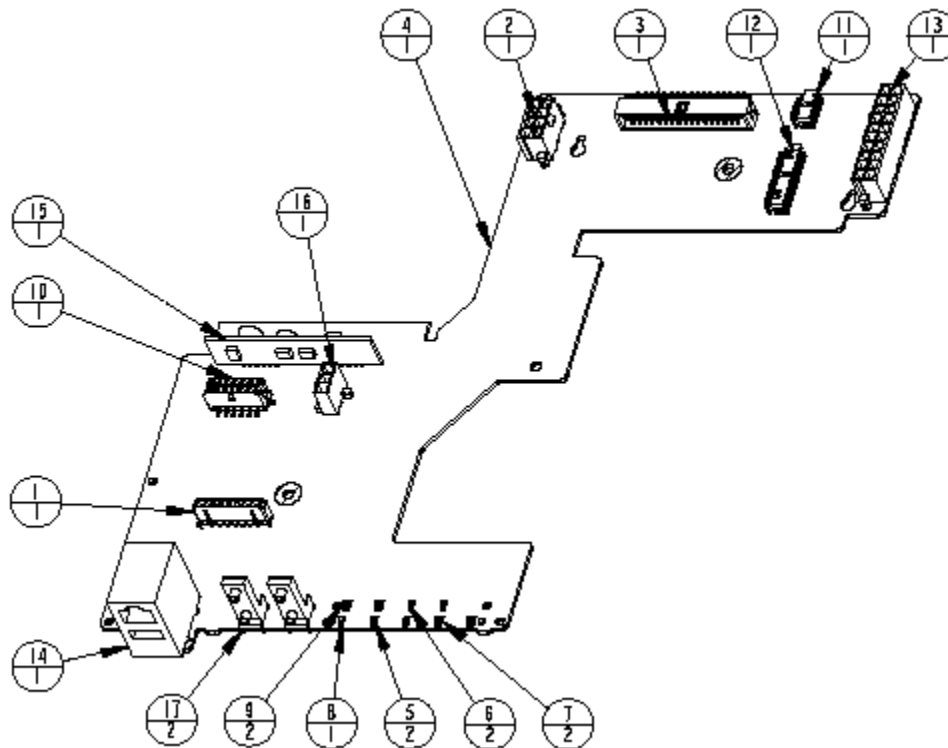

Figure 4-2. Extended Front Panel Board Connector Location

Table 4-9. Connector Housing Information

Conn	Function	Intel PN	AML	s/k/l/p*	cnt	hsn
Extended Front Panel Board						
J2G1	USB 1 x 8	C13083-007	Molex 43650-0817	y/y/y/y	30u"	94V0
J5A1	uP Pwr 2 x 4	A81170-001	Molex 39-29-9086	y/y/y/y	Tin	94V0
J8A1	FP 2 x 17	A57940-002	Foxconn HL15177	y/y/y/y	15u"	94V0
J1E1	MP 2 x 6	691314-004	Molex 43045-1218	y/y/y/y	Tin	94V0
J9A1	BB Pwr/Sig mm 2 x 5 2	700000-772	Molex 87333-1021	y/y/n/y	30u"	94V0
J9B1	Alarm/COM 2 x 12 2 mm	A62345-003	Molex 87333-2420	y/y/n/y	15u"	94V0
J10A1	Baseboard (BB) Pwr 2 x 10	703141-001	Molex 39-29-9207	y/y/y/y	Tin 35u"	94V0
J1J1	COM2/USB	680356-004	680358-004	y/y/y/y	30u"	94V0
J3E1	Riser Pwr 1 x 3	703140-002	Molex 39-30-2036	y/y/y/y	Tin 35u"	94V0

s/k/l/p* - shrouded/keyed/latching/polarized

4.5.1 Extended Front Panel Board USB Connector Pinout

The following table details the pin-out of the USB connector to the SE7210TP1-E System Baseboard.

Table 4-10. 8-pin (1 x 8) USB J2G1 Connector

Pin	USB Signal
1	GND
2	GND
3	FP_USB_N
4	FP_USB_P
5	USBPWR
6	GND
7	GND
8	GND

4.5.2 Extended Front Panel Board uProcessor Power Connector Pinout

The following table details the pin-out of the uP power connector to the SE7210TP1-E System Baseboard.

Table 4-11. 8-pin (2 x 4) uP Power J5A1 Connector

Pin	uP Power Signal	Pin	uP Power Signal
1	GND	2	P12V_A
3	GND	4	P12V_A
5	GND	6	P12V_A
7	GND	8	P12V_A

4.5.3 Extended Front Panel Board Front Panel Connector Pinout

The following table details the pin-out of the front panel connector to the SE7210TP1-E System Baseboard.

Table 4-12. 34-pin (2 x 17) Front Panel J8A1 Connector

Pin	Front Panel Signal	Pin	Front Panel Signal
1	GND	2	P5V_STBY
3	Keying Pin	4	NC_FAN_FAIL_PWR
5	PWR_ON_LED_N	6	NC_POWER_FAIL_PWR
7	NC_HD_ACT_PWR	8	NC_POWER_FAIL_PWR
9	NC_HD_ACT_N	10	FP_SYS_FLT_LED_N
11	FP_PWR_BTN_N	12	P3V3_STBY
13	GND	14	NIC1_LED_N
15	FP_RST_BTN_N	16	NC_FP_SDA
17	GND	18	NC_FP_SCL
19	NC_SLEEP_BTN	20	NC_SSI_PIN20
21	GND	22	P3V3_STBY
23	FP_NMI_BTN_N	24	NIC2_LED_N
25	NC_SSI_PIN25	26	NC_SSI_PIN26
27	P5V_STBY	28	P5V_STBY
29	FP_ID_LED_N	30	STATUS_LED_N
31	FP_ID_LED_N	32	P5V
33	GND	34	NC_HDD_FLT_N

4.5.4 Extended Front Panel Board Midplane Connector Pinout

The following table details the pin-out of the connector to the Mid-Plane System Baseboard.

Table 4-13. 12-pin (2 x 6) Mid-Plane J1E1 Connector

Pin	Mid-Plane Signal	Pin	Mid-Plane Signal
1	SCSI0_5V	2	SCSI0_12V
3	SCSI1_5V	4	SCSI1_12V
5	ACT_SCSI0_N	6	P5V
7	GND	8	GND
9	GND	10	SCSI0_MATED_N
11	ACT_SCSI1_N	12	SCSI1_MATED_N

4.5.5 Extended Front Panel Board Power/Signal Connector Pinout

The following table details the pin-out of the power/signal connector to the SE7210TP1-E System Baseboard.

Table 4-14. 10-pin (2 x 5) Power/Signal J9A1 Connector

Pin	Power/Signal Signal	Pin	Power/Signal Signal
1	PS_SCL	2	PS_SDA
3	PS_ALERT_N	4	GND_REM_SENSE
5	PWR_REM_SENSE	6	PWOK
7	PSON_N	8	N12V
9	P5V	10	GND

4.5.6 Extended Front Panel Board Alarm/COM2 Connector Pinout

The following table details the pin-out of the Alarm/COM2 connector to the SE7210TP1-E System Baseboard (COM2) and to the chassis rear access port (Alarm).

Table 4-15. 24-pin (2 x 12) Alarm/COM2 J9B1 Connector

Pin	Front Panel Signal	Pin	Front Panel Signal
1	GND	2	MIN_RST_P
3	RS232_RI	4	MINR_NC
5	RS232_DTR	6	MIN_RST_N
7	RS232_CTS	8	MINR_COMM
9	RS232_TXD	10	MAJ_RST_P
11	RS232_RTS	12	MAJ_NO
13	RS232_RXD	14	MAJ_RST_N
15	RS232_DSR	16	MAJ_NC
17	RS232_DCD	18	CRIT_NO
19	CRIT_COM	20	MAJ_COMM
21	POWER_COMM	22	CRIT_NC
23	MIN_NO	24	POWER_NO

4.5.7 Extended Front Panel Board Baseboard Power Connector Pinout

The following table details the pin-out of the baseboard power connector to the SE7210TP1-E System Baseboard

Table 4-16. 20-pin (2 x 10) Baseboard Power J10A1 Connector

Pin	Front Panel Signal	Pin	Front Panel Signal
1	P3V3	2	P3V3
3	P3V3	4	P3V3
5	P5V	6	P5V
7	P5V	8	P12V_A
9	P12V_A	10	GND
11	GND	12	GND
13	GND	14	GND
15	P5V	16	P5V
17	GND	18	GND
19	GND	20	P5V_STBY

4.5.8 Extended Front Panel Board COM2/USB Connector Pinout

The following table details the pin-out of the front access panel COMM/USB connector.

Table 4-17. 16-pin Baseboard Power J1A1 Connector

Pin	USB Signal	Pin	COM2 Signal
1	GND	9	RJ45_RTS
2	GND	10	RJ45_DTR
3	GND	11	RJ45_TXD
4	GND	12	GND
5	USBPWR	13	RJ45_RI
6	USB_TOP_DM	14	RJ45_RXD
7	USB_TOP_DP	15	RJ45_DSR_DCD*
8	GND	16	RJ45_CTS

* Pin 15 RJ45_DSR_DCD is selected via jumpers on J3H1 on the extended front panel board as follows:

J3H1 Pin1 to Pin2 – select DSR

J3H1 Pin 2 to Pin 3 – select DCD

4.5.9 Extended Front Panel Board NEBS Riser Power Connector Pinout

The following table details the pin-out of the 1 x 3 NEBS Riser Power connector.

Table 4-18. 3-pin (1 x 3) NEBS Riser Power J3E1 Connector

Pin	1 x 3 Power Signal
1	P5V_A
2	GND
3	GND

4.6 SCSI Power Subsystem

The SCSI power subsystem on the extended front panel board is designed to provide power delivery to the two SCSI hot-swappable hard drives that are mated to the midplane peripheral board. The design enables on-demand power delivery of +5 V and +12 V to the SCSI drives, without the need to power cycle the Intel® TIGPT1U during drive insertion/removal.

4.6.1 SCSI Drive Power Control

The SCSI power management circuit is intended to support the control function for hot-insertion of the two SCSI hard drives. The design enables on-the-fly replacement of the SCSI hard drives without powering down the system.

SCSI Power Control includes SCSI drive power switching, over-current protection, and system status notification.

Once a SCSI drive is mated to the chassis, the control circuit begins to turn on approximately 48 mS after the drive's `scsi_mated` signal goes low. Power to the SCSI device 5 V line begins to ramp approximately 6 mS after the control circuit is activated, and the SCSI 12 V line begins to ramp approximately 8 mS after the control circuit is activated. The `scsi_mated` signal not only activates the power control circuit, it also notifies server management software through the SMBus that the drive has been inserted. After the output voltages are stable, the power control circuit provides an active high `power_good` signal to the server management software to notify that the 5 V and 12 V supplies are at nominal voltage.

The SCSI power control circuit contains current sensing mechanism to detect conditions where excessive current are being drawn. When the current draw reaches 5 A on either the 12 V or 5 V supply, the control circuit disconnects power to the drive and times out for 9.4 mS ($200\text{ K}\Omega * C_{\text{tim}} = 200\text{ K} * .047\text{ }\mu\text{F}$).

4.6.2 Internal SCSI Drive Power Switching

Each SCSI drive is supplied with +12 V and +5 V. Separate Metal-Oxide Semiconductor Field Effect (MOSFET) switches apply and remove the +12 V and +5 V to each internal SCSI drive.

4.6.3 SCSI Drive Status LEDs

The status LEDs give the user a visual indication of the drives' condition. There is a single LED for each drive. The LEDs are bi-colored and use a combination of color and blinking frequency to indicate multiple conditions. The LEDs are mounted on the extended front panel system board, and the light is directed to the front panel through the use of a light pipe assembly. See Table 4-19 for LED activity definitions. See Firmware EPS for definitions of the different blink rates.

Table 4-19. LED Activity Definitions

LED State	Drive Active	Fault Condition
Solid Green		
Blinking Green	X	
Solid Yellow/Red		X
Blinking Yellow/Red		X
Blank		

4.7 Specifications

4.7.1 Electrical Specifications

DC specifications for the Intel® TIGPT1U extended front panel board power connectors are summarized in this section. All power rails must operate within +/- 5% voltage range.

Table 4-20. Maximum Power Requirements (mA)

CIRCUIT FUNCTION	P12V_B		P5V		P5V_STBY		P3V3_STBY		POWER Dissipation (Watts) TYP	POWER Dissipation (Watts) MAX
	TYP (mA)	MAX (mA)	TYP (mA)	MAX (mA)	TYP (mA)	MAX (mA)	TYP (mA)	MAX (mA)		
STATUS LEDs			41	56	3	17				
ALARM RELAY CNTL					0.4	76				
ALARM LEDs					0.3	55				
I/O EXPANDERS			22	26	4	6	0	0.0		
SCSI CONTROLLERS	22	55								
TOTAL CURRENT(mA)	22	55	63	82	7.7	154	0	0.6	0.6175	1.93416
POWER(W)	0.264	0.693	0.315	0.4305	0.0385	0.8085	0	0.00216	0.6175	1.93416

Note: Software limits 2 alarms active at once power fault and one of major, minor or critical alarms.

Alarms connector relay contacts are rated at 1 A with a maximum rating of 30 W(DC) / 60 VA (AC).

Alarms connector external alarm (major and/or minor) reset is an optoisolated input that is reverse voltage protected. A voltage of 3.3 V to 48 V input with a pulse width of at least 200 ms is required to activate the alarm-reset function. Maximum current is 12 mA.

5. Power Interconnect System Board

This chapter describes the basic functions and interface requirements of the power interconnect board that is designed for the Intel® Carrier Grade Server TIGPT1U.

5.1 Features

- Used to interconnect between the power supply and the extended front panel board
- Two connectors on the board, No active components on board

5.2 Chapter Structure and Outline

The information contained in this chapter is organized into two sections. The information is presented in a modular format, with numbered headings for each major topic and subtopic. The content of each section is summarized as follows:

Section 5.1: Functional Description of Power Interconnect System Board

Provides an overview of the Intel® Carrier Grade Server TIGPT1U Front Panel I/O (FPIO) Board and a physical board layout diagram.

Section 5.2: Connector Description

Provides connector descriptions for all connectors on the interface board.

5.3 Functional Description of Power Interconnect System Board

The power interconnect board is used to interconnect between the power supply and the extended front panel board. Both the power supply and the front panel board have card-edge fingers to interface to the card-edge connectors on the power interconnect system board.

Power passes from the 250 watt power supply through the power interconnect system board to the extended front panel system board. Power is then distributed from the extended front panel system board to the other system boards via discrete cables.

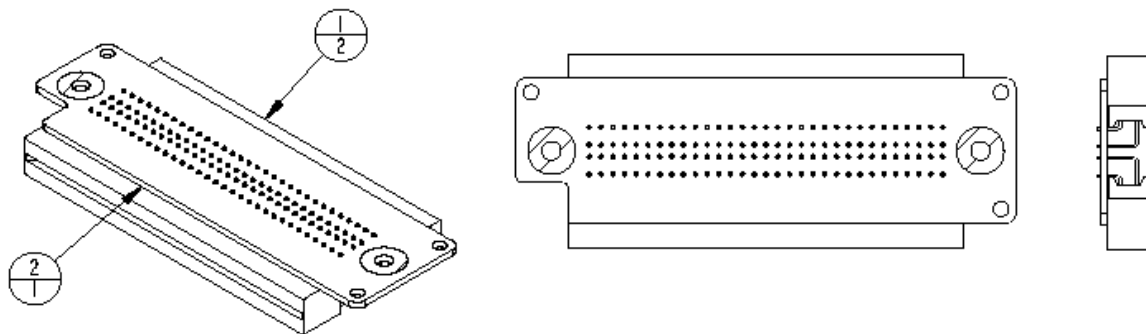

2/1 – Board

1/2 – AMP 532600-4 Connector, Card Edge, Right-Angle

Figure 5-1. Physical Layout of Power Interconnect System Board

5.4 Connector Description

5.4.1 Connector Mating to the Power Supply Pinout

The following table details the pin-out of the 2 x 31 connector that is used to interface to the card-edge connector on the 250 watt power supply.

Table 5-1. 2 x 31 Connector Pinout to 250 Watt Power Supply

Pin	Power Supply Signal	Pin	Power Supply Signal
1	N12V	32	P3V3
2	PWOK	33	P3V3
3	RESERVED1	34	P3V3
4	RESERVED2	35	P5V
5	5VSB	36	P5V
6	NC	37	P5V
7	RESERVED3	38	GND
8	RESERVED4	39	GND
9	RESERVED5	40	GND
10	RESERVED6	41	GND
11	P12V_B	42	GND
12	P12V_B	43	GND
13	P12V_B	44	GND
14	P12V_A	45	GND
15	P12V_A	46	GND
16	P12V_A	47	P12V_A
17	GND	48	P12V_A
18	GND	49	P12V_A
19	GND	50	P12V_B
20	GND	51	P12V_B
21	GND	52	P12V_B
22	GND	53	RESERVED7
23	GND	54	RESERVED8
24	GND	55	PWR_REM_SENSE
25	GND	56	RESERVED9
26	P5V	57	RESERVED10
27	P5V	58	GND_REM_SENSE
28	P5v	59	PS_ALERT_N
29	P3V3	60	PS_SCL
30	P3V3	61	PS_SDA
31	P3V3	62	PS_ON_N

5.4.2 Connector Mating to the Extended Front Panel System Board Pinout

The following table details the pin-out of the 2 x 31 connector that is used to interface to the card-edge connector on the extended front panel system board.

Table 5-2. 2 x 31 Connector Pinout to Extended Front Panel System Board

Pin	Power Supply Signal	Pin	Power Supply Signal
1	P3V3	32	PSON_N
2	P3V3	33	PS_SDA
3	P3V3	34	PS_SCL
4	P5V	35	PS_ALERT_N
5	P5V	36	GND_REM_SENSE
6	P5v	37	RESERVED10
7	GND	38	RESERVED9
8	GND	39	PWR_REM_SENSE
9	GND	40	RESERVED8
10	GND	41	RESERVED7
11	GND	42	P12V_B
12	GND	43	P12V_B
13	GND	44	P12V_B
14	GND	45	P12V_A
15	GND	46	P12V_A
16	P12V_A	47	P12V_A
17	P12V_A	48	GND
18	P12V_A	49	GND
19	P12V_B	50	GND
20	P12V_B	51	GND
21	P12V_B	52	GND
22	RESERVED6	53	GND
23	RESERVED5	54	GND
24	RESERVED4	55	GND
25	RESERVED3	56	GND
26	NC	57	P5V
27	5VSB	58	P5V
28	RESERVED2	59	P5V
29	RESERVED1	60	P3V3
30	PWOK	61	P3V3
31	N12V	62	P3V3

6. NEBS 3.3 V Riser Board

This chapter describes the design and external interface of the Intel® TIGPT1U NEBS 3.3 V riser board. Features of the NEBS 3.3 V riser board include:

- One 66 MHz 3.3 V 64-bit PCI slot
- A 1 x 3 power connector to provide 5V power to support one Peripheral Component Interconnect (PCI) adapter with a maximum power requirement of 25 watts (5 V @ 5 A). Note that the 5 V power rail is only connected to the 1 x 3 power connector. 5 V supply connections from the baseboard are disconnected at the riser connector.

6.1 Chapter Structure and Outline

The information contained in this chapter is organized into four sections. The information is presented in a modular format, with numbered headings for each major topic and subtopic. The content of each section is summarized as follows:

Section 6.2: Functional Description:

Provides a functional description of the NEBS 3.3 V riser board.

Section 6.3: Connector Interface:

Gives signal descriptions and the corresponding electrical parameters for each input and output of a given connector.

Section 6.4: Electrical Specification:

Describes the electrical, environmental, and mechanical specifications.

6.2 Functional Description

The NEBS 3.3 V riser board contains one 66 MHz 3.3 V 64-bit slot. A 1 x 3 power connector is used to provide 5 V power to the PCI adapter plugged into the NEBS 3.3 V riser board, and is capable of supporting a PCI adapter with a maximum wattage of 25 watts (5 V @ 5 A).

The riser is intended to mate to slot 1 of the Baseboard. The riser can accept 5 V from either the baseboard edge fingers or through the connector cable assembly from the XFPB. Selecting between the two supplies are done as follows:

1. To select P5V_A from the XFPB -- Install cable from the PDB to J1A1 and depopulate RP7A1, RP7A2, RP7A3 (default state).
2. To select P5V from baseboard -- Install RP7A1, RP7A2, RP7A3 and remove cable from the PDB.

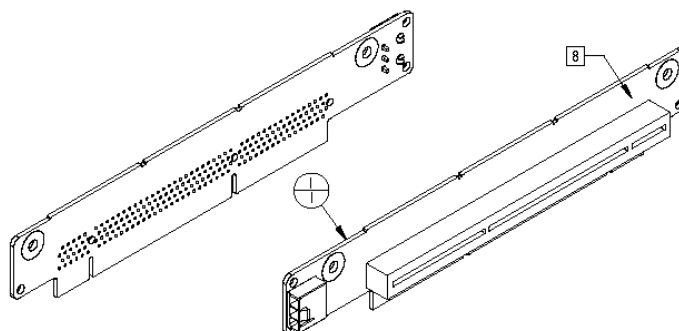

1/1 – Board
 8 – Connector 10028958-X3184 Conn, PCI, 3.3 V, Low Profile
 1 x 3 Connector – Molex 39-30-3036

Figure 6-1. Physical Layout of NEBS 3.3 V Riser Board

6.3 Connector Interface

Table 6-1 describes the common signals between the edge finger and the system baseboard.

Table 6-1. Riser Card Slot Pin-out Common Signals

Pin	Side B	Side A	Pin	Side B	Side A
1	-12 V	TRST_N	49	M66EN	AD[09]
2	TCK	+12 V	50	Ground	Ground
3	Ground	TMS	51	Ground	Ground
4	TDO	TDI	52	AD[08]	C/BE[0]#
5	+5 V	+5 V	53	AD[07]	+3.3 V
6	+5 V	INTA_N	54	+3.3 V	AD[06]
7	INTB_N	INTC_N	55	AD[05]	AD[04]
8	INTD_N	+5 V	56	AD[03]	Ground
9	PRSNT1_N	NC	57	Ground	AD[02]
10	NC	+3V_IO	58	AD[01]	AD[00]
11	PRSNT2_N	NC	59	+3V_IO	+3V_IO
	Connector Key	Connector Key	60	ACK64#	REQ64#
	Connector Key	Connector Key	61	+5 V	+5 V
14	NC	3.3 VAUX	62	+5 V	+5 V
15	Ground	RST#		Connector Key	Connector Key
16	CLK	+3V_IO		Connector Key	Connector Key
17	Ground	GNT_N	63	Reserved	Ground
18	REQ_N	Ground	64	Ground	C/BE[7]#
19	+3V_IO	PME#	65	C/BE[6]#	C/BE[5]#
20	AD[31]	AD[30]	66	C/BE[4]#	VIO
21	AD[29]	+3.3 V	67	Ground	PAR64
22	Ground	AD[28]	68	AD[63]	AD[62]

Pin	Side B	Side A	Pin	Side B	Side A
23	AD[27]	AD[26]	69	AD[61]	Ground
24	AD[25]	Ground	70	+3V_IO	AD[60]
25	+3.3 V	AD[24]	71	AD[59]	AD[58]
26	C/BE[3]#	IDSEL	72	AD[57]	Ground
27	AD[23]	+3.3 V	73	Ground	AD[56]
28	Ground	AD[22]	74	AD[55]	AD[54]
29	AD[21]	AD[20]	75	AD[53]	+3V_IO
30	AD[19]	Ground	76	Ground	AD[52]
31	+3.3 V	AD[18]	77	AD[51]	AD[50]
32	AD[17]	AD[16]	78	AD[49]	Ground
33	C/BE[2]#	+3.3 V	79	+3V_IO	AD[48]
34	Ground	FRAME#	80	AD[47]	AD[46]
35	IRDY#	Ground	81	AD[45]	Ground
36	+3.3 V	TRDY#	82	Ground	AD[44]
37	DEVSEL#	Ground	83	AD[43]	AD[42]
38	Ground	STOP#	84	AD[41]	+3V_IO
39	LOCK#	+3.3 V	85	Ground	AD[40]
40	PERR#	SMBUS SCL	86	AD[39]	AD[38]
41	+3.3 V	SMBUS SDA	87	AD[37]	Ground
42	SERR#	Ground	88	+3V_IO	AD[36]
43	+3.3 V	PAR	89	AD[35]	AD[34]
44	C/BE[1]#	AD[15]	90	AD[33]	Ground
45	AD[14]	+3.3 V	91	Ground	AD[32]
46	Ground	AD[13]	92	NC	NC
47	AD[12]	AD[11]	93	NC	Ground
48	AD[10]	Ground	94	Ground	NC

Table 6-2 describes the common signals between the PCI card connector and PCI edge fingers.

Table 6-2. PCI Card Connector Signals

Pin	Side B	Side A	Pin	Side B	Side A
1	-12 V	TRST_N	49	M66EN	AD[09]
2	TCK	+12 V	50	Ground	Ground
3	Ground	TMS	51	Ground	Ground
4	TDO	TDI	52	AD[08]	C/BE[0]#
5	+5V_A	+5V_A	53	AD[07]	+3.3 V
6	+5V_A	INTA_N	54	+3.3 V	AD[06]
7	INTB_N	INTC_N	55	AD[05]	AD[04]
8	INTD_N	+5V_A	56	AD[03]	Ground
9	PRSNT1_N	NC	57	Ground	AD[02]
10	NC	+3V_IO	58	AD[01]	AD[00]
11	PRSNT2_N	NC	59	+3V_IO	+3V_IO
	Connector Key	Connector Key	60	ACK64#	REQ64#
	Connector Key	Connector Key	61	+5V_A	+5V_A
14	NC	3.3 VAUX	62	+5V_A	+5V_A

Pin	Side B	Side A	Pin	Side B	Side A
15	Ground	RST#		Connector Key	Connector Key
16	CLK	+3V_IO		Connector Key	Connector Key
17	Ground	GNT_N	63	Reserved	Ground
18	REQ_N	Ground	64	Ground	C/BE[7]#
19	+3V_IO	PME#	65	C/BE[6]#	C/BE[5]#
20	AD[31]	AD[30]	66	C/BE[4]#	VIO
21	AD[29]	+3.3 V	67	Ground	PAR64
22	Ground	AD[28]	68	AD[63]	AD[62]
23	AD[27]	AD[26]	69	AD[61]	Ground
24	AD[25]	Ground	70	+3V_IO	AD[60]
25	+3.3 V	AD[24]	71	AD[59]	AD[58]
26	C/BE[3]#	IDSEL	72	AD[57]	Ground
27	AD[23]	+3.3 V	73	Ground	AD[56]
28	Ground	AD[22]	74	AD[55]	AD[54]
29	AD[21]	AD[20]	75	AD[53]	+3V_IO
30	AD[19]	Ground	76	Ground	AD[52]
31	+3.3 V	AD[18]	77	AD[51]	AD[50]
32	AD[17]	AD[16]	78	AD[49]	Ground
33	C/BE[2]#	+3.3 V	79	+3V_IO	AD[48]
34	Ground	FRAME#	80	AD[47]	AD[46]
35	IRDY#	Ground	81	AD[45]	Ground
36	+3.3 V	TRDY#	82	Ground	AD[44]
37	DEVSEL#	Ground	83	AD[43]	AD[42]
38	Ground	STOP#	84	AD[41]	+3V_IO
39	LOCK#	+3.3 V	85	Ground	AD[40]
40	PERR#	SMBUS SCL	86	AD[39]	AD[38]
41	+3.3 V	SMBUS SDA	87	AD[37]	Ground
42	SERR#	Ground	88	+3V_IO	AD[36]
43	+3.3 V	PAR	89	AD[35]	AD[34]
44	C/BE[1]#	AD[15]	90	AD[33]	Ground
45	AD[14]	+3.3 V	91	Ground	AD[32]
46	Ground	AD[13]	92	NC	NC
47	AD[12]	AD[11]	93	NC	Ground
48	AD[10]	Ground	94	Ground	NC

6.3.1 NEBS Riser Power Connector Pinout

The following table details the pin-out of the 1 x 3 NEBS Riser Power connector.

Table 6-3. 3-pin (1 x 3) NEBS Riser Power J1A1 Connector

Pin	1 x 3 Power Signal
1	+5V_A
2	GND
3	GND

6.4 Electrical Specification

The PCI slot on the riser is limited to a maximum of 25 W total power from the installed PCI adapter. This maximum power per slot conforms to *PCI Specification 2.2*.

7. Midplane Board

This chapter describes the design and external interface of the Intel® TIGPT1U Midplane system board. Features of the midplane system board include:

- SCSI Hot Swap Hard Disk Drive SCA Connectors
- SCSI ULTRA320 Active Terminators
- SCSI Hard Disk Drive Power Management

7.1 Chapter Structure and Outline

The information contained in this chapter is organized into four sections. The information is presented in a modular format, with numbered headings for each major topic and subtopic. The content of each section is summarized as follows:

Section 7.2: Introduction:

Provides an overview of the Intel® TIGPT1U midplane system board, showing primary components and their relationships, and physical board layout diagrams.

Section 7.3: Functional Description:

Provides a functional description of the midplane system board.

Section 7.4: Connector Interface:

Gives signal descriptions and the corresponding electrical parameters for each input and output of a given connector.

Section 7.5: Specifications:

Describes the electrical, environmental and mechanical specifications.

7.2 Introduction

The Intel® TIGPT1U midplane peripheral board provides all SCSI subsystem components necessary to interface to the hot plug SCSI SCA hard disk drives. This includes the SCSI hot swap hard disk drive SCA connectors, the SCSI ultra320 active terminators, the SCSI hard disk drive power management circuitry, and the SCSI contact sense circuit for detecting the presence of SCSI hot swap hard disk drives.

The following figure shows a functional block diagram of the midplane system board.

7.3 Functional Description

The SCSI subsystem on the midplane board is designed to give the end user support for two SCSI hot-plug hard drives. The design enables easy use and replacement of the SCSI hard drives without powering down the system. The following block diagram and functional description will explain how the midplane SCSI subsystem works.

7.3.1 Midplane System Board SCSI Subsystem Block Diagram

The block diagram in Figure 7-1 illustrates the general architecture of the midplane board SCSI subsystem. The physical and functional blocks of the SCSI subsystem are shown, with arrows representing buses and signals, and the blocks representing the functional parts of the SCSI subsystem.

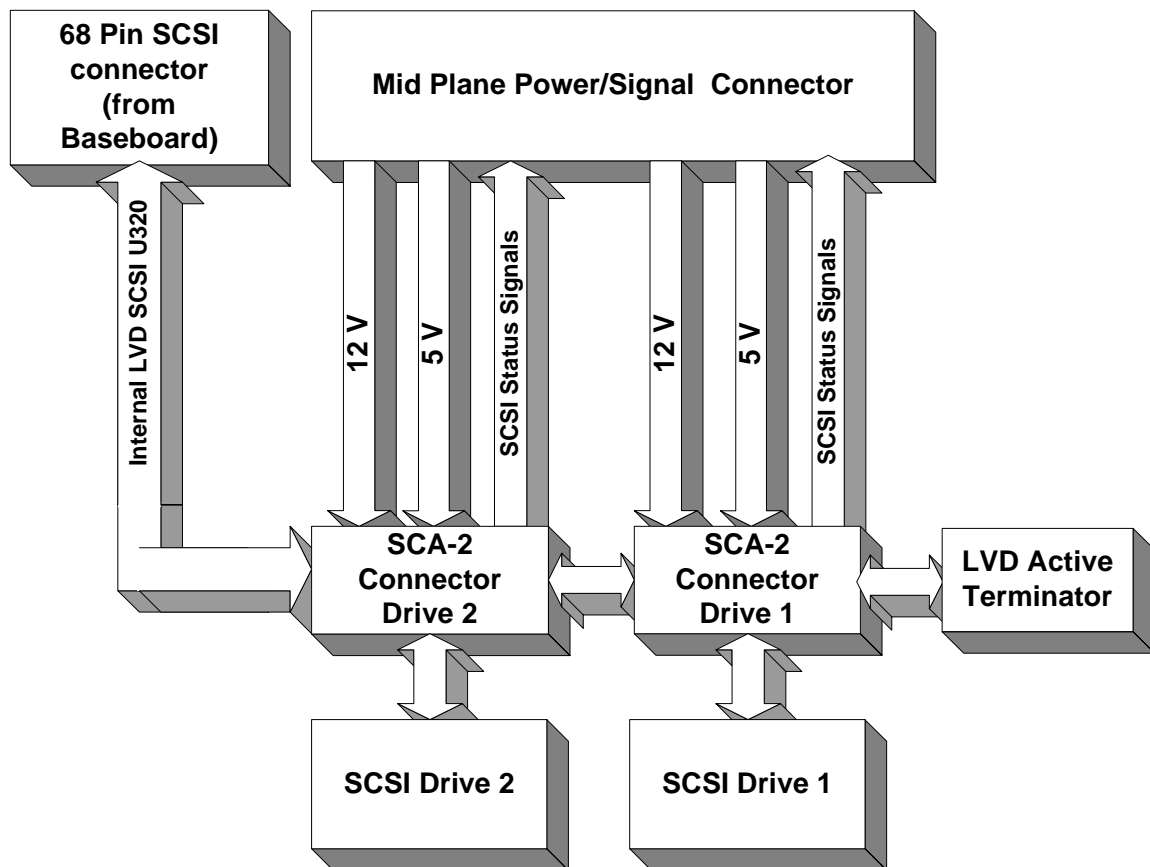

Figure 7-1. Midplane System Board SCSI Subsystem Block Diagram

7.3.2 SCSI Bus

The midplane system board SCSI subsystem passes the SCSI bus from the SE7210TP1-E System Baseboard to the internal SCSI drives. The SCSI bus is Ultra 320 (SPI-4) capable. Single-Ended (SE) drives are not supported. SE drives should not be installed as the behavior of the drives is unpredictable and data corruption could result. The bus is comprised of 68 signals. The bus clock is 80 MHz. The 320 Mbytes data rate results from double transition (DT) data transfers on a two byte wide bus. The SCSI bus attaches to the SE7210TP1-E System Baseboard via a 68-pin SCSI connector.

$$320 \text{ Mbytes/s} = 2 \text{ byte bus} * 80 \text{ MHz clock} * \text{double transitions.}$$

NOTE: The SCSI drives and SCSI controller on the SE7210TP1-E System Baseboard determine actual SCSI bus data rate.

7.3.3 SCA2 Connector Interlocks

The SCA2 connectors on the Midplane board (MPB) have interlocks. The mated1 and mated2 signals are used to provide Interlock notification for the SCSI device and Baseboard, respectively. Sensing and delay circuitry on the MPB will utilize the input mating signal from the drive to monitor hot insertion. Approximately 60 mS after hot insertion, the MPB activates its own mated acknowledgement signal to the drive to notify the drive that it can safely power-up.

7.3.4 Signal Descriptions

The following notations are used to describe the signal type, from the perspective of the FPIO SCSI subsystem:

Notation	Description
I	Input pin to the SCSI subsystem
O	Output pin from the SCSI subsystem
I/O	Bi-directional (input/output) pin
PWR	Power Supply pin

The signal description also includes the type of buffer used for the particular signal:

Notation	Description
LVD	Low Voltage Differential SCSI
SE	Standard Single Ended SCSI
TTL	5 V TTL signals
CMOS	5 V CMOS signals
3.3 V CMOS	3.3 V CMOS signals
Analog	Typically a voltage reference or specialty power supply

7.3.4.1 LVD SCSI Connectors

The low voltage differential (LVD) connector carries signals between the midplane SCSI bus and internal SCSI drives through the SCSI SCA connectors. The LVD SCSI bus's signals are driven by either the baseboard SCSI controller, the LVD/SE Transceiver, or the internal SCSI drives. Table 7-1 provides a description of each signal on the SCSI connectors.

Table 7-1. LVD SCSI Bus Signals – J2L1, J4A1, J8A1

Signal	Type	Driver	Name and Description
DB_[15..0][P, N]	I/O	LVD/	SCSI Data Bus. These pins, with the DBP[1/0][P/N] pins form the bi-directional SCSI data bus.
DB_P0[P, N] DB_P1[P, N]	I/O	LVD/	SCSI Data Parity. These pins support parity on the SCSI bus. DBP0[P/N] supports parity for data [7..0] DBP1[P/N] supports parity for data [15..8]
DIFFSENSE	I	Analog	Differential Sense. This pin monitors the DIFFSENSE signal from the terminator. The voltage level determines the operating mode of the target devices on the SCSI bus. If the voltage on the DIFFSENSE signal is from –0.35 V to +0.5 V the mode will be SE. If it is from +0.7 V to 1.9 V the mode will be LVD.
ATN_[P, N]	I/O	LVD/	SCSI Bus Attention. These pins are asserted by a SCSI device in initiator mode to alert the target that the initiator has a message to transfer.
BSY_[P, N]	I/O	LVD	SCSI Bus Busy. In SE mode, these pins are bi-directional and are asserted to gain use of the SCSI bus and to indicate that that SCSI bus is in use.
ACK_[P, N]	I/O	LVD	SCSI Bus Acknowledge. These pins are asserted by a SCSI device in initiator mode to acknowledge the target's request for a data transfer.
RST_[P, N]	I/O	LVD	SCSI Bus Reset. In SE mode, these pins are bi-directional and are asserted when all the SCSI devices attached to the SCSI bus need to be reset.
MSG_[P, N]	I/O	LVD	SCSI Bus Message Phase. These pins are asserted by a SCSI device in target mode to indicate the Message In or Message Out phase.
SEL_[P, N]	I/O	LVD	SCSI Bus Select. In SE mode, these pins are bi-directional and are asserted by the controller when attempting to select or reselect a SCSI device.
CD_[P, N]	I/O	LVD	SCSI Bus Control/Data Phase. These pins are asserted or de-asserted by a SCSI device in target mode to indicate that control or data information is being transferred over the SCSI bus
REQ_[P, N]	I/O	LVD	SCSI Bus Request. These pins are asserted by a SCSI device in target mode to indicate that the target is requesting a data transfer over the SCSI bus.
IO_[P, N]	I/O	LVD	SCSI Bus I/O Phase. These pins are asserted by a SCSI device in target mode to indicate the direction of data movement on the SCSI bus between the target and the initiator.
SCSI_ID	O	GND/OPEN	SCSI ID. Sets internal SCSI ID depending on slot. Drive 0 has SCSI address 0. Drive 1 has SCSI address 1.
MATED [1,2]	I/O	TTL	SCSI MATED. Pins are used to determine if SCSI is present and has proper contact. See T10/1302D Annex C for additional information.

Signal	Type	Driver	Name and Description
GND	I/O	PWR	Ground. These pins provide Secondary Ground reference.
P12V	O	PWR	+12-V supply. Max 1.5 A of continuous current. Max 5 amps peak current.
P5V	O	PWR	+5-V supply. Max 1.5 A of continuous current. Max 5 amps peak current.

7.4 Connector Interface

The following table shows all the connectors on the midplane system board, the interconnect used for each connector, and the destination for the interconnect. In addition, the first column references the location on the following figure of the connector location.

Table 7-2. Extended Front Panel System Board Connector Information

FPIO Board Connections				
Loc	Ref Des	Function	Interconnect	Connects to
1	J9L1	2x6 Midplane Pwr/Sig Conn	Main Power (MP) Cable	Extended Front Panel Pwr/Sig Conn
2	J4A1	80 Pin SCA SCSI Conn	N/A	SCSI SCA Hard Disk Drive
3	J8A1	80 Pin SCA SCSI Conn	N/A	SCSI SCA Hard Disk Drive
4	J2L1	64 Pin SCSI Connector	SCSI Cable	Baseboard SCSI Connector

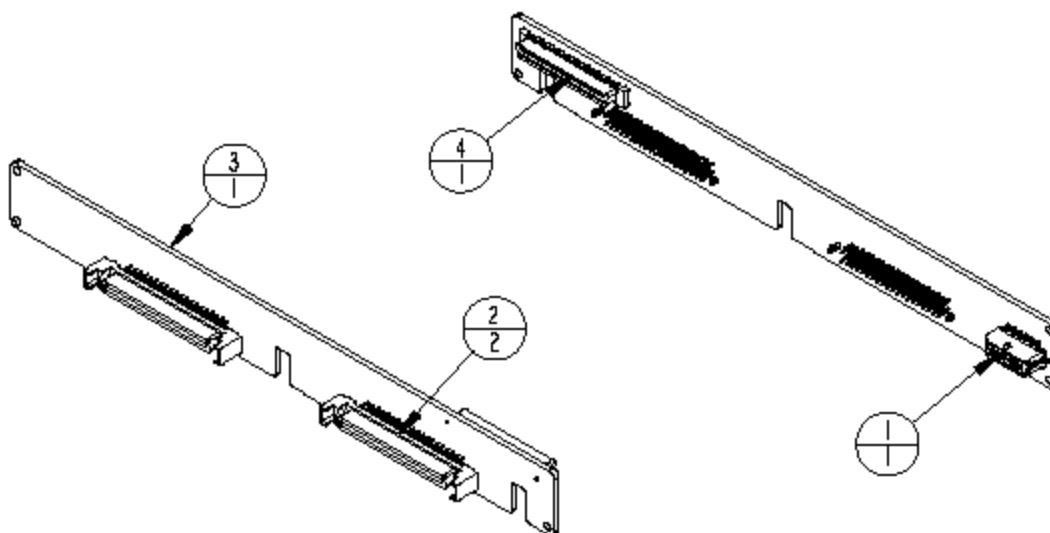

Figure 7-2. Extended Front Panel Board Connector Location

Table 7-3. Connector Housing Information

Conn	Function	Intel PN	AML	s/k/l/p*	cnt	hsn
Extended Front Panel Board						
J9L1	2x6 Midplane Pwr/Sig	691314-004	Molex 43045-1218	y/y/y/y	tin	94V0
J4A1	80 Pin SCA SCSI Conn	626530-380	Fxconn LS2640X-C64	y/y/n/y	30u"	94V0
J8A1	80 Pin SCA SCSI Conn	626530-380	Fxconn LS2640X-C64	y/y/n/y	30u"	94V0
J2L1	68 Pin SCSI Connector	628525-069	Molex 15-87-0305	y/y/n/y	30u"	94V0

s/k/l/p* - shrouded/keyed/latching/polarized

7.4.1 Midplane Power/Signal Connector Pinout

The following table details the pin-out of the midplane power/signal connector

Table 7-4. 12-pin (2 x 6) Midplane J9L1 Connector

Pin	Midplane Signal	Pin	Midplane Signal
1	SCSI0_5V	2	SCSI0_12V
3	SCSI1_5V	4	SCSI1_12V
5	ACT_SCSI0_N	6	P5V
7	GND	8	GND
9	GND	10	SCSI0_MATED_N
11	ACT_SCSI1_N	12	SCSI1_MATED_N

7.4.2 Midplane SCSI Connector Pinout and SCSI ID settings

The 68 Pin SCSI connector pinout and the 80 Pin SCSI SCA connector will not be documented, since they conform to standard SCSI connector pinouts. The SCSI ID for each hard drive position is hardwired on the midplane board, so the use of jumper(s) to select a unique SCSI ID is not necessary. Hard disk drive position 1 is hardwired to SCSI ID 0 on the SCSI bus and hard disk drive position 2 is hardwired to SCSI ID 1 on the SCSI bus.

7.5 Specifications

7.5.1 Electrical Specifications

DC specifications for the Intel® TIGPT1U midplane system board power connectors are summarized in this section. All power rails must operate within +/- 5% voltage range.

Table 7-5. MPB Power Requirements

CIRCUIT FUNCTION	P12V_B		P5V		POWER DISSIPATION (Watts) TYP	POWER DISSIPATION (Watts) MAX
	TYP(mA)	MAX(mA)	TYP(mA)	MAX(mA)		
ACTIVE TERMINATORS			22	27		
SCSI CONTROLLERS	22	55				
TOTAL CURRENT(mA)	22	55	22	27	0.374	0.83475
POWER(W)	0.264	0.693	0.11	0.14175	0.374	0.83475

8. DC Power Subsystem

This chapter defines the features and functionality of the DC-input power supply. The DC-input power supply will be NEBS hardened, so NEBS certification of the Intel® Carrier Grade Server TIGPT1U will be performed with the Intel® TIGPT1U configured with a DC-input power supply.

8.1 Features

- 250 W output capability in full DC input voltage range
- Power good indication LED
- Predictive failure warning
- Cooling fans with multispeed capability
- Remote sense of 3.3 V, 5 V, and 12 Vdc outputs
- DC_OK circuitry for brown out protection and recovery
- Built-in overloading protection capability
- Onboard field replaceable unit (FRU) information
- I²C interface for server management functions

8.2 Chapter Structure and Outline

The information contained in this chapter is organized into three sections. The information is presented in a modular format, with numbered headings for each major topic and subtopic. The content of each section is summarized as follows:

Section 8.3: Introduction

Provides an overview of the Intel® TIGPT1U DC-input power subsystem.

Section 8.4: Mechanical Interface

Describes the form factor and connector pinouts.

Section 8.5: Electrical Requirements

Describes the electrical parameters for the inputs and outputs.

8.3 Introduction

The Intel® Carrier Grade Server TIGPT1U uses a –48 V DC-input switching power subsystem, which provides up to 250 W DC with –48 V DC-input and with current and remote sense regulation. All power supply module connectors accommodate “blind mating.” The power subsystem has four externally enabled outputs, and one +5 V standby output at 2.0 A. The +5 Vdc standby output is present whenever –48V DC power is applied. The four externally enabled outputs have the following ratings:

Table 8-1. 250 Watt DC-input Power Supply DC Output Ratings

+3.3 V at 16 A
+5 V at 12 A
+12V1 (baseboard) at 16 A with 17 A peak (combined +12V1 & +12V2 <= 18 A)
+12V2 (peripherals) at 10 A with 22 A peak (combined +12V1 & +12V2 <= 18 A)
-12 V at 0.5 A
+5VSB at 2.0 A

8.4 Mechanical Interface

8.4.1 Power Supply Cage Mechanical Outline

The Intel® Carrier Grade Server TIGPT1U's C-input power supply mechanical outline and dimensions are shown below. The unit of measurement is millimeters.

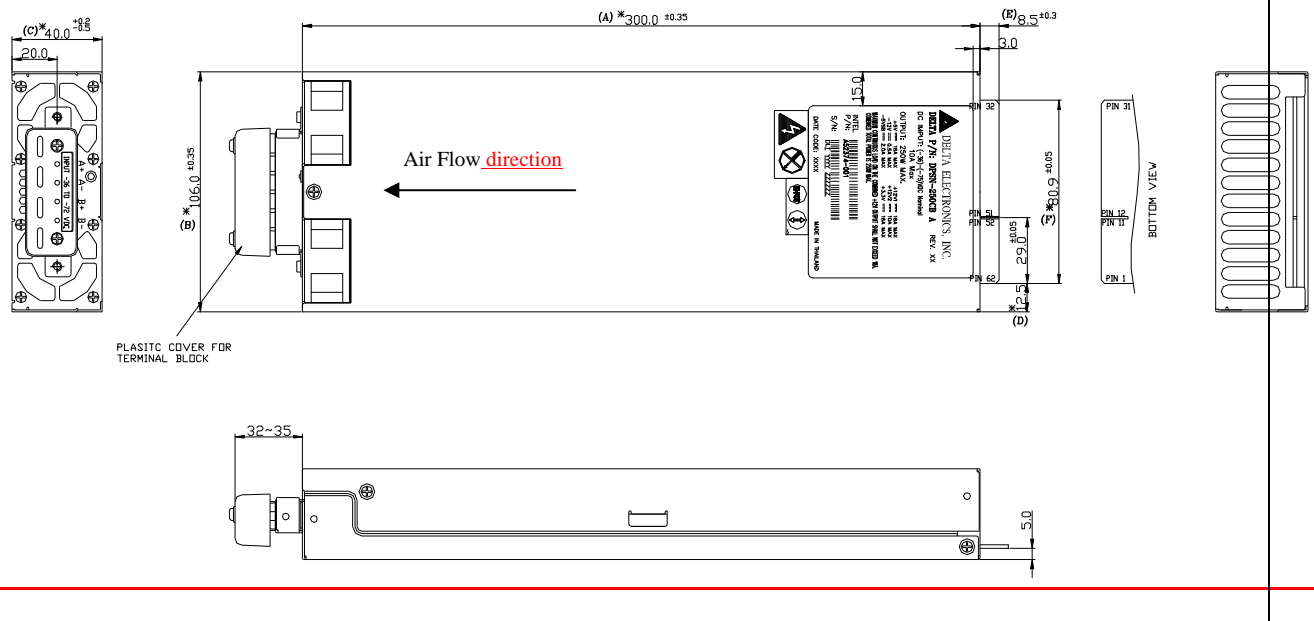

Figure 8-1. Power Subsystem Enclosure Outline Drawing

Note: The power subsystem enclosure has dimensions of 40.0 mm (1.57") H X 106.0 mm (4.17") W X 300.0 mm (11.8") D.

8.4.2 DC Input Terminal Block Connector

The power input DC line connector is a 4-position terminal strip that accepts crimp ring terminals. The terminal strip has 0.325" (8.26 mm) center spacing and accepts 0.25" outside diameter (OD) crimp ring terminals for up to 14 AWG wire. In addition, a plastic protective cover is mounted over the terminal strip and fastened with 2 screws. This is shown in the following figure.

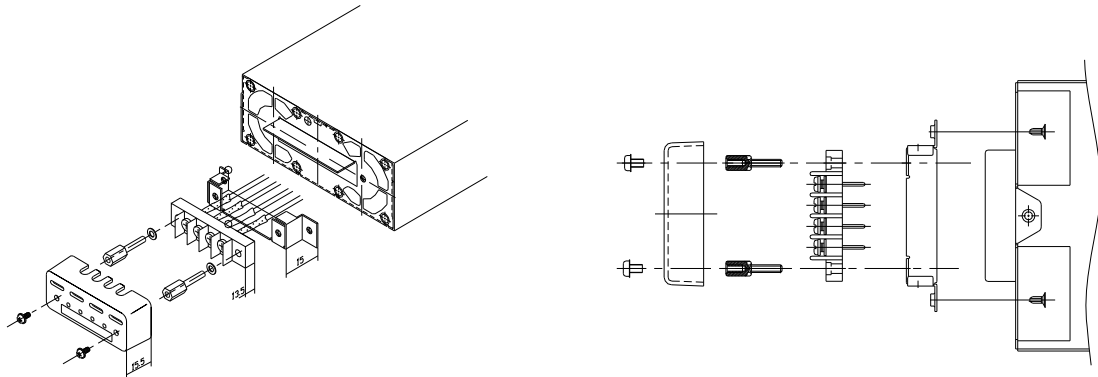

Figure 8-2. DC Input Terminal Block

The terminal block will accept standard terminal lugs size Newark stock # 81N1501 type CRS-T0-1406-HT that accept 14 AWG wire gauge. The width of the lug can be no larger than 0.25 inches.



Figure 8-3. Terminal Lug

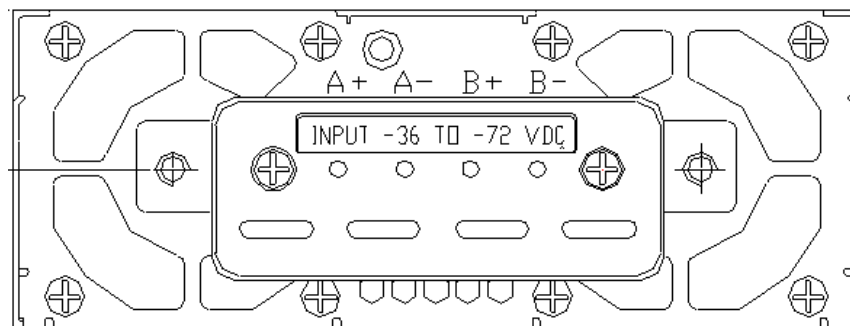

Figure 8-4. Terminal Block Polarity

8.4.3 DC Output Connector

The power supply provides card edge fingers, which mate to a connector located in the system. This is a blind mating type connector that connects the power supply's output voltages and signals. The card edge fingers are located on the power supply as shown below. Card edge finger pin assignments are listed below. The figure below shows the card edge layout for the power supply. The connector located in the system is an AMP* 1364999-1* or equivalent.

Table 8-2. Edge Finger Pinout

Description	Pin#	Pin#	Description
-12 V	1	62	PSON#
PWOK	2	61	SDA
Reserved	3	60	SCL
Reserved	4	59	Reserved
5VSB	5	58	Returns
Removed keying pin (NC)	6	57	Reserved
Reserved	7	56	Reserved
Reserved	8	55	3.3VS
Reserved	9	54	Reserved
Reserved	10	53	Reserved
12V2	11	52	12V2
12V2	12	51	12V2
12V2	13	50	12V2
12V1	14	49	12V1
12V1	15	48	12V1
12V1	16	47	12V1
Ground	17	46	Ground
Ground	18	45	Ground
Ground	19	44	Ground
Ground	20	43	Ground
Ground	21	42	Ground
Ground	22	41	Ground
Ground	23	40	Ground
Ground	24	39	Ground
Ground	25	38	Ground
5 V	26	37	5 V
5 V	27	36	5 V
5 V	28	35	5 V
3.3 V	29	34	3.3 V
3.3 V	30	33	3.3 V
3.3 V	31	32	3.3 V

← keying position

Signals that can be defined as low true or high true use the following convention: *signal#* = low true
Reserved pins are reserved for future use.

Note: All dimensions are in mm.-

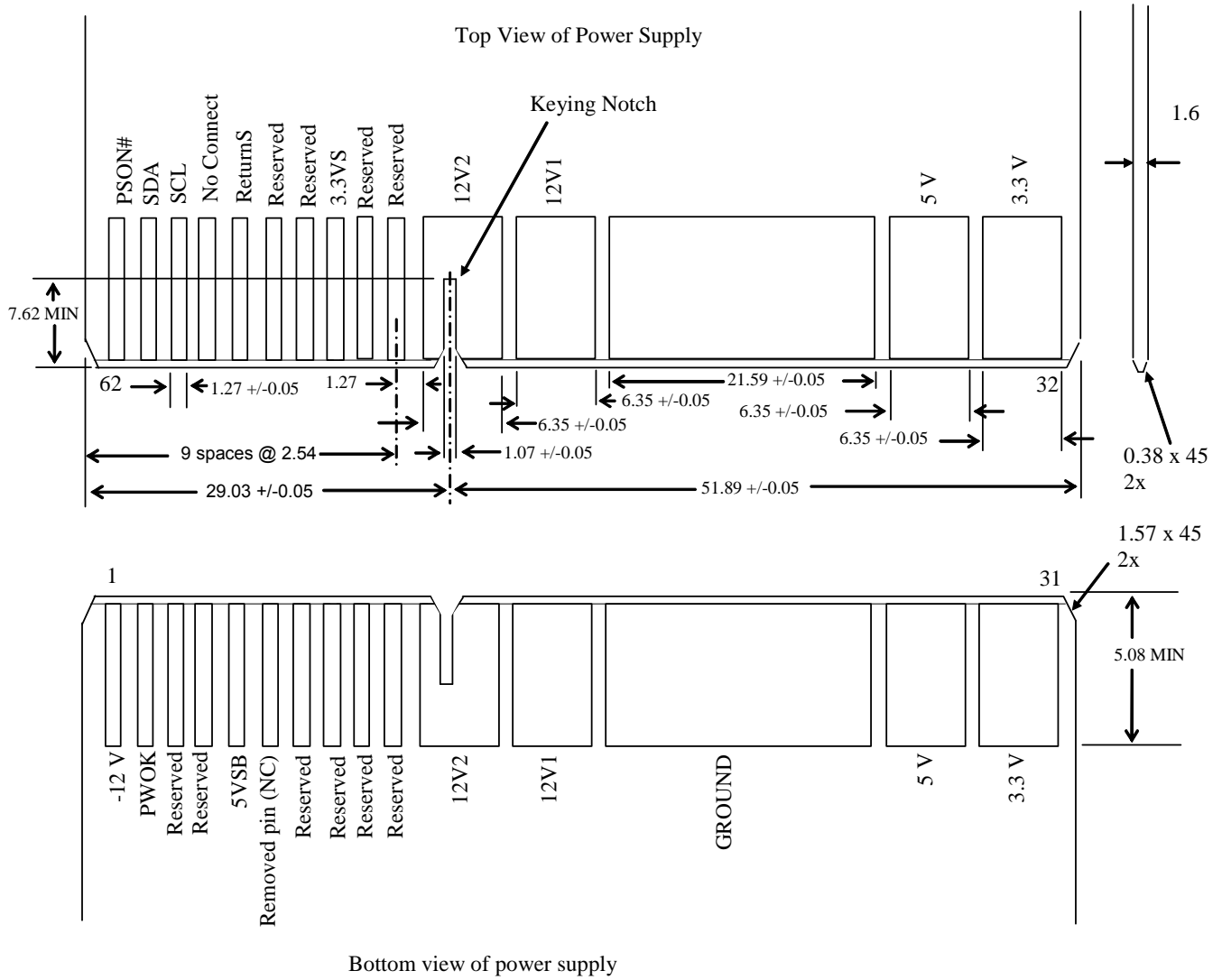

Figure 8-5. Edge Finger Layout

8.4.4 Power Supply Module LED Indicators

There is a single bi-color LED to indicate power supply status. When DC line is applied to the Power Supply Unit (PSU) and standby voltages are available the LED blinks green. The LED turns on solid green to indicate that all the power outputs are available. In case of over-current protection (OCP), over-voltage protection (OVP), over-temperature protection (OTP), fan failure, or under voltage, the LED turns on solid amber. Refer to the table below.

Table 8-3. LED Indicators

POWER SUPPLY CONDITION	Power Supply LED
No DC line power to all PSU	Off
DC line present / Only Standby Outputs On	Blink Green
Power supply DC outputs ON and OK	Green
Power supply shutdown due to over current, over temperature, fan failure, over voltage, or under voltage.	Amber
Power supply failed and DC line fuse open or other critical failure.	Amber or Off

8.5 Electrical Requirements

8.5.1 DC Input Voltage Specification

The power supply is capable of supplying full rated output power over entire nominal –48/-60 VDC that covers the range from –38 VDC to –75 VDC. The power supply will automatically recover from DC power loss. The input voltage and current requirements for continuous operation are stated below. The power supply is able to start up under peak loading at any input voltage listed below.

Table 8-4. DC Input Rating

Parameter	Min	Nom	Max	Unit
V _{in} (-48 VDC)	- 38.0	- 48.0/-60.0	- 75.0	VDC
I _{in} (-38 VDC)			- 9.4	ADC
I _{in} (-75 VDC)			- 4.75	ADC

8.5.2 Dual DC Input

The power supply requires a dual power feed (A and B battery feed). The A and B feeds are interconnected via blocking diodes with 250 VDC minimum blocking voltage rating. The power supply provides four series diodes, one for each wire feed. The power supply also provides two internal slow-blow fuses, one on each –48 V input wire.

8.5.3 DC Output Current Specifications

The combined output power of all outputs can not exceed 250 W. Each output has a maximum and minimum current rating shown. The power supply meets both static and dynamic voltage regulation requirements for the minimum loading conditions.

Table 8-5. 250 W Load Ratings

Voltage	Minimum Continuous Load	Maximum Continuous Load	Peak Load	Max Continuous Wattage
+3.3 V	1.5 A	16 A		52.8 W
+5 V	1.0 A	12 A		60.0 W
+12V1	1.5 A	16 A (see note 3)	22.0 A	216.0 W
+12V2	0.5 A	10 A (see note 3)	See note 2	(see note 3)
-12 V	0 A	0.5 A		6.0 W
+5VSB	0.1 A	2.0 A		10.0 W
			Total =	250 W = see note 1

1. Maximum continuous total DC output power should not exceed 250 Watts.
2. Peak load on the combined 12 V output shall not exceed 22 A (while 12V1 shall not exceed 17 A pk).
3. Maximum continuous load on the combined 12 V output shall not exceed 18 A.
4. Peak total DC output power should not exceed 300 Watts.
5. Peak power and current loading shall be supported for a minimum of 12 seconds.

9. AC Power Subsystem

This chapter defines the features and functionality of the AC-input switching power subsystem. The AC power supply will not be NEBS hardened, so NEBS certification of an Intel® Carrier Grade Server TIGPT1U configured with an AC power subsystem will not be possible.

9.1 Features

- 250 W output capability in full AC input voltage range
- Power good indication LED
- Predictive failure warning
- Cooling fans with multispeed capability
- Remote sense of 3.3 V, 5 V, and 12 Vdc outputs
- AC_OK circuitry for brown out protection and recovery
- Built-in overloading protection capability
- Onboard field replaceable unit (FRU) information
- I²C interface for server management functions

9.2 Chapter Structure and Outline

The information contained in this chapter is organized into three sections. The information is presented in a modular format, with numbered headings for each major topic and subtopic. The content of each section is summarized as follows:

Section 9.3: Introduction

Provides an overview of the Intel® TIGPT1U AC-input power subsystem.

Section 9.4: Mechanical Interface

Describes the form factor and connector pin-outs.

Section 9.5: Electrical Requirements

Describes the electrical parameters for the inputs and outputs.

9.3 Introduction

The Intel® Carrier Grade Server TIGPT1U uses an AC input switching power subsystem, which provides up to 250 W DC with 110/220 Voltage of Alternating Current (VAC) input and with current and remote sense regulation. All power supply connectors, including AC and DC connectors, accommodate “blind mating.” The power subsystem has four externally enabled outputs, and one +5 V standby output at 2.0 A. The +5 Vdc standby output is present whenever 110/220 VAC power is applied. The four externally enabled outputs have the following ratings:

Table 9-1. 250 Watt AC-input Power Supply DC Output Ratings

+3.3 V at 16 A
+5 V at 12 A
+12V1 (baseboard) at 16 A with 17 A peak (combined +12V1 & +12V2 <= 18 A)
+12V2 (peripherals) at 10 A with 22 A peak (combined +12V1 & +12V2 <= 18 A)
-12 V at 0.5 A
+5VSB at 2.0 A

9.4 Mechanical Interface

9.4.1 Power Supply Cage Mechanical Outline

The Intel® TIGPT1U's AC-input power supply mechanical outline and dimensions are shown below. The unit of measurement is millimeters.

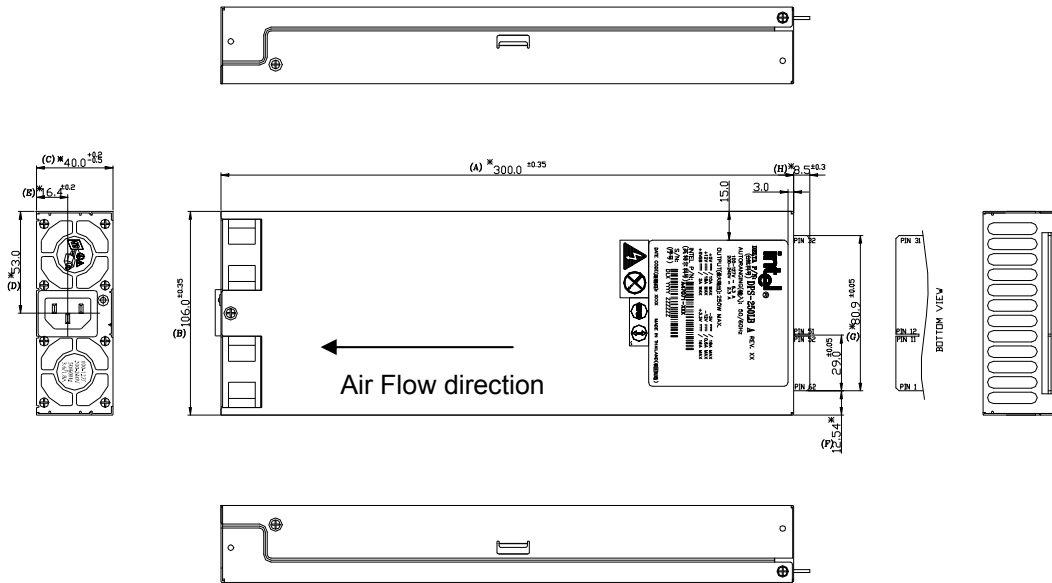

Figure 9-1. Power Subsystem Enclosure Outline Drawing

Note: The power subsystem enclosure has dimensions of 40.0 mm (1.57") H X 106.0 mm (4.17") W X 300.0 mm (11.8") D.

9.4.2 AC Input Connector

The AC input connector shall be an International Electrotechnical Commission (IEC) 320 C-14 power inlet. This inlet is rated for 15 A/250 VAC.

9.4.3 DC Output Connector

The power supply provides card edge fingers, which mate to a connector located in the system. This is a blind mating type connector that connects the power supply's output voltages and signals. The card edge fingers are located on the power supply as shown below. Card edge finger pin assignments are listed below. The figure below shows the card edge layout for the power supply. The connector located in the system is an AMP 1364999-1 or equivalent.

Table 9-2. Edge Finger Pinout

Description	Pin#	Pin#	Description
-12 V	1	62	PSON#
PWOK	2	61	SDA
Reserved	3	60	SCL
Reserved	4	59	Reserved
5VSB	5	58	Returns
Removed keying pin (NC)	6	57	Reserved
Reserved	7	56	Reserved
Reserved	8	55	3.3VS
Reserved	9	54	Reserved
Reserved	10	53	Reserved
12V2	11	52	12V2
12V2	12	51	12V2
12V2	13	50	12V2
12V1	14	49	12V1
12V1	15	48	12V1
12V1	16	47	12V1
Ground	17	46	Ground
Ground	18	45	Ground
Ground	19	44	Ground
Ground	20	43	Ground
Ground	21	42	Ground
Ground	22	41	Ground
Ground	23	40	Ground
Ground	24	39	Ground
Ground	25	38	Ground
5 V	26	37	5 V
5 V	27	36	5 V
5 V	28	35	5 V
3.3 V	29	34	3.3 V
3.3 V	30	33	3.3 V
3.3 V	31	32	3.3 V

← keying position

Signals that can be defined as low true or high true use the following convention: *signal*[#] = low true
Reserved pins are reserved for future use.

Note: All dimensions are in mm.

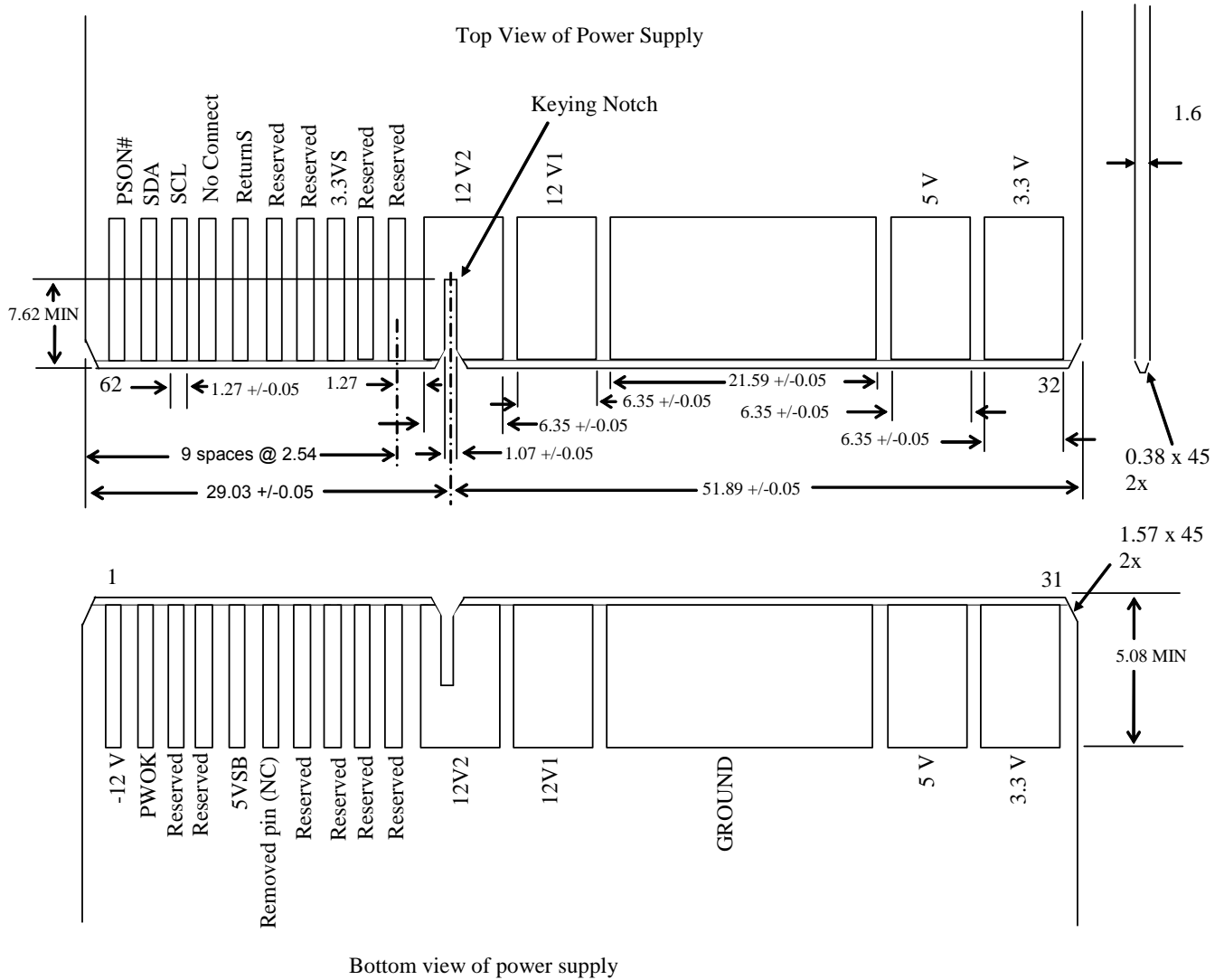

Figure 9-2. Edge Finger Layout

9.4.4 Power Supply Module LED Indicators

There is a single bi-color LED to indicate power supply status. When AC is applied to the PSU and standby voltages are available the LED blinks green. The LED turns on solid green to indicate that all the power outputs are available. In case of OCP or OVP or OTP or fan failure or under voltage the LED should turn ON solid amber. Refer to the following table for conditions of the LEDs.

Table 9-3. LED Indicators

POWER SUPPLY CONDITION	Power Supply LED
No AC power to all PSU	Off
AC present / Only Standby Outputs On	Blink Green
Power supply DC outputs ON and OK	Green
Power supply shutdown due to over current, over temperature, fan failure, over voltage, or under voltage.	Amber
Power supply failed and AC fuse open or other critical failure.	Amber or Off

9.5 Electrical Requirements

9.5.1 AC Input Voltage Specification

The power supply will operate within all specified limits over the following input voltage ranges. Harmonic distortion of up to 10% THD will not cause the power supply to go out of specified limits. The power supply shall power off if the AC input is less than 70 VAC. The power supply shall operate properly at 85 VAC input voltage to guarantee proper design margins.

Table 9-4. AC Input Rating

PARAMETER	MIN	RATED	MAX	Max Input Current	Max Rated Input Current
Voltage (110)	90 V _{rms}	100-127 V _{rms}	140 V _{rms}	5.7 A _{rms} ^{1,3}	3.6 A _{rms}
Voltage (220)	180 V _{rms}	200-240 V _{rms}	264 V _{rms}	2.3 A _{rms} ^{2,3}	1.8 A _{rms}
Frequency	47 Hz		63 Hz		

- 1 Maximum input current at low input voltage range shall be measured at the lowest input voltage which the power supply continues to operate (70 VAC ≤ Vin < 85 VAC).
- 2 Maximum input current at high input voltage range shall be measured at 180 VAC.
- 3 This is not intended to be used for determining agency input current markings.
Maximum rated input current is measured at 100 VAC and 200 VAC.

10. Regulatory Specifications

The Intel® Carrier Grade Server TIGPT1U meets the specifications and regulations for safety and EMC defined in this chapter.

10.1 Safety Compliance

USA/Canada	UL 60950, 3rd Edition/CSA 22.2, No. 60950-0, 3rd Edition
Europe	Low Voltage Directive, 73/23/EEC TUV/GS to EN60950 3 rd Edition
International	CB Certificate and Report to IEC 950, 3 rd Edition including EMKO-TSE (74-SEC) 207/94 and all international deviations

10.2 Electromagnetic Compatibility

USA	FCC 47 CFR Parts 2 and 15, Verified Class A Limit
Canada	IC ICES-003 Class A Limit
Europe	EMC Directive, 89/336/EEC EN55022, Class A Limit, Radiated & Conducted Emissions EN55024 Immunity Characteristics for ITE EN61000-4-2 ESD Immunity (level 2 contact discharge, level 3 air discharge) EN61000-4-3 Radiated Immunity (level 2) EN61000-4-4 Electrical Fast Transient (level 2) EN61000-4-5 Surge EN61000-4-6 Conducted RF EN61000-4-8 Power Frequency Magnetic Fields EN61000-4-11 Voltage Fluctuations and Short Interrupts EN61000-3-2 Harmonic Currents EN61000-3-3 Voltage Flicker
Australia/New Zealand	AS/NZS 3548, Class A Limit
Japan	VCCI Class A ITE (CISPR 22, Class A Limit) IEC 1000-3-2; Harmonic Currents
Taiwan	BSMI Approval, CNS 13438, Class A
Korea	RRL Approval, Class A
China	CCC Approval
Russia	Gost Approval
International	CISPR 22, Class A Limit

10.3 CE Mark

The CE marking on this product indicates that it is in compliance with the European Union's EMC Directive 89/336/EEC, and Low Voltage Directive, 73/23/EEC.

10.4 NEBS Compliance (DC Input Only)

The Intel® TIGPT1U with DC input is compliant with the following NEBS specifications:

- NEBS GR-63-CORE, Issue 2 – Physical Protection
- NEBS GR-1089-CORE, Issue 3 – Electromagnetic Compatibility and Electrical Safety

10.5 ETSI Standards Compliance (DC Input Only)

The Intel® TIGPT1U with DC input is compliant with the following ETSI specifications:

- ETSI EN 300 386 EMC requirements for Telecom Equip.
- ETS 300-019-2-1 Storage Tests, Class T1.2
- ETS 300-019-2-2 Transportation Tests, Class T2.3
- ETS 300-019-2-3 Operational Tests, Class T3.2
- ETS 753 Acoustic Noise

Appendix A: Glossary

This appendix contains important acronyms and terms used in the preceding chapters.

Term	Definition
A, Amp	Ampere
A/μs	Amps per microsecond
AC	Alternating current
ACPI	Advanced Configuration and Power Interface
ANSI	American National Standards Institute
APIC	Advanced Programmable Interrupt Controller
ASIC	Application specific integrated circuit
AWG	American wire gauge
BIOS	Basic input/output system
BMC	Baseboard management controller
Bridge	Circuitry that connects one computer bus to another
Byte	8-bit quantity
C	Centigrade
CE	Community European
CFM	Cubic feet per minute
CISPR	International Special Committee on Radio Interference
CSA	Canadian Standards Organization
CTS	Clear to send
DAT	Digital audio tape
dB	Decibel
dBA	Acoustic decibel
DC	Direct current
DIMM	Dual inline memory module
DMI	Desktop management interface
DOS	Disk operating system
DRAM	Dynamic random access memory
DSR	Data set ready
DTR	Data terminal ready
DWORD	Double word - 32-bit quantity
ECC	Error checking and correcting
EEPROM	Electrical erasable programmable read-only memory
EMC	Electromagnetic compatibility
EMI	Electromagnetic interference
EMP	Emergency management port
EN	European Standard (Norme Européenne or Europäische Norm)
EPS	External product specification
ESCD	Extended system configuration data
ESD	Electrostatic discharge
ESR	Equivalent series resistance
F	Fahrenheit

Term	Definition
FCC	Federal Communications Commission
FFC	Flexible flat connector
Flash ROM	EEPROM
FPC	Front panel controller
FRB	Fault resilient booting
FRU	Field replaceable unit
G	Acceleration in gravity units, 1G = 980665 m/s ²
GB	Gigabyte - 1024 MB
GND	Ground
GPIO	General purpose input/output
Grms	Root mean square of acceleration in gravity units
GUI	Graphical user interface
HDD	Hard disk drive
HPIB	Hot-plug indicator board
HSC	Hot-swap controller
Hz	Hertz – 1 cycle/second
I/O	Input/output
I ² C*	Inter-integrated circuit bus
ICMB	Intelligent Chassis Management Bus
IDE	Integrated drive electronics
IEC	International Electrotechnical Commission
IEEE	Institute of Electrical and Electronics Engineers
IFLASH	Utility to update Flash EEPROM
IMB	Intelligent management bus
IPMB	Intelligent Platform Management Bus
IPMI	Intelligent Platform Management Initiative
IRQ	Interrupt request line
ITE	Information technology equipment
ITP	In-target probe
JAE	Japan Aviation Electronics
KB	Kilobyte - 1024 bytes
kV	Killivolt – 1,000 volts
L2	Second-level cache
LAN	Local area network
LED	Light-emitting diode
LVDS	Low voltage differential SCSI
mA	Milliamp
MB	Megabyte - 1024 KB
MEC	Memory expansion card
mm	Millimeter
MPS	Multiprocessor specification
MTTR	Mean time to repair
mΩ	Milliohm
NEMKO	Norges Elektriske Materiekkontroll (Norwegian Board of Testing and Approval of Electrical Equipment)

Term	Definition
NIC	Network interface card
NMI	Nonmaskable interrupt
NWPA	NetWare* Peripheral Architecture
ODI	Open data-link interface
OEM	Original equipment manufacturer
OPROM	Option ROM (expansion BIOS for a peripheral)
OS	Operating system
OTP	Over-temperature protection
OVP	Over-voltage protection
PC-100	Collection of specifications for 100 MHz memory modules
PCB	Printed circuit board
PCI	Peripheral component interconnect
PHP	PCI hot-plug
PID	Programmable interrupt device
PIRQ	PCI interrupt request line
PMM	POST memory manager
PnP	Plug and play
POST	Power-on Self Test
PSU	Power supply unit
PVC	Polyvinyl chloride
PWM	Pulse width modulation
RAS	Reliability, availability, and serviceability
RIA	Ring indicator
RPM	Rotations per minute
RTS	Request to send
SAF-TE	SCSI Accessed Fault-Tolerant Enclosures
SCA	Single connector attachment
SCL	Serial clock
SCSI	Small Computer System Interface
SDR	Sensor data records
SDRAM	Synchronous dynamic RAM
SEC	Single edge connector
SEL	System event log
SELV	Safety extra low voltage
SEMKO	Sverge Elektriske Materiellkontroll (Swedish Board of Testing and Approval of Electrical Equipment)
SGRAM	Synchronous graphics RAM
SM	Server management
SMBIOS	System management BIOS
SMBus	Subset of I ² C bus/protocol (developed by Intel)
SMI	System management interrupt
SMM	Server management mode
SMP	Symmetric multiprocessing
SMRAM	System management RAM
SMS	Server management software

Term	Definition
SPD	Serial presence detect
SSI	Server system infrastructure
TUV	Technischer Überwachungs-Verein (A safety testing laboratory with headquarters in Germany)
UL	Underwriters Laboratories, Inc.
USB	Universal Serial Bus
UV	Under-voltage
V	Volt
VA	Volt-amps (volts multiplied by amps)
Vac	Volts alternating current
VCCI	Voluntary Control Council for Interference
Vdc	Volts direct current
VDE	Verband Deutscher Electrotechniker (German Institute of Electrical Engineers)
VGA	Video graphics array
VRM	Voltage regulator module
VSB	Voltage standby
W	Watt
WfM	Wired for Management
Word	A 16-bit quantity
Ω	Ohm
μF	Microfarad
μs	Microsecond

Appendix B: Reference Documents

Refer to the following documents for additional information:

ACPI

- *Advanced Configuration And Power Interface Specification*, Revision 1.0b, <http://www.teleport.com/~acpi/>.

AMI* BIOS

- <http://www.ami.com/support/doc/Server.pdf>

Boot

- *BIOS Boot Specification*, Version 1.01, <http://www.ptltd.com/techs/specs.html>.
- *El Torito CD-ROM Boot Specification*, Version 1.0, <http://www.ptltd.com/techs/specs.html>.

DMI

- *Desktop Management Interface (DMI) Specification*, Version 2.0s, Desktop Management Task Force, Inc., <http://www.dmtf.org/spec/dmis.html>.

ESCD

- *Extended System Configuration Data Specification*, Version 1.02a, <http://www.microsoft.com/hwdev/respec/PNPSPECS.HTM>.

Ethernet

- *Intel 82547EI Gigabit Ethernet Controller Datasheet*, Intel Corporation, <http://www.intel.com/design/network/products/lan/controllers/82547ei.htm>
- *Intel 82541EI Gigabit Ethernet Controller Datasheet*, Intel Corporation, <http://www.intel.com/design/network/products/lan/controllers/82541gi.htm>

Flash

- *Intel 5 VOLT FlashFile™ Memory (28F008SA x8) Datasheet*, December 1998, Intel Corporation, Number 290429-008, <http://developer.intel.com/design/flcomp/datashts/290429.htm>.

I₂O

- *Intelligent Input/Output (I₂O) Architecture Specification*, Revision 1.0, I₂O Special Interest Group, <http://www.Intelligent-IO.com>

MPS

- *MultiProcessor Specification*, Version 1.4, Intel Corporation, <http://www-techdoc.intel.com/design/intarch/manuals/242016.htm>.

PC133 SDRAM

- *PC SDRAM Registered DIMM Specification*, Revision 1.2, Intel Corporation, <http://developer.intel.com/technology/memory/>.
- *PC SDRAM Specification*, Revision 1.63, Intel Corporation, <http://developer.intel.com/technology/memory/>.
- *PC SDRAM Serial Presence Detect (SPD) Specification*, Revision 1.2A, Intel Corporation, <http://developer.intel.com/technology/memory/>.

PCI

- *PCI Bus Power Management Interface Specification*, Revision 1.1, PCI Special Interest Group, <http://www.pcisig.com/>.
- *PCI Local Bus Specification*, Revision 2.1, PCI Special Interest Group, <http://www.pcisig.com/>.
- *PCI Hot-plug Specification*, Revision 1.0, PCI Special Interest Group, <http://www.pcisig.com/>.
- *PCI Hot-plug Application and Design*, Alan Goodrum, ISBN 0-929392-60-4.
- *Compaq PCI Hot-Plug Megacell Specification*.

PID

- *Programmable Interrupt Device External Product Specification*, Revision 1.1, Intel Corporation, Document number OR4-680777.

Plug and Play

- *Plug and Play BIOS Specification*, Version 1.0a, <http://www.microsoft.com/hwdev/respec/PNPSPECS.HTM>.
- *Clarification to Plug and Play BIOS Specification*, Version 1.0a, <http://www.microsoft.com/hwdev/respec/PNPSPECS.HTM>.
- *Plug and Play ISA Specification*, Version 1.0a, <http://www.microsoft.com/hwdev/respec/PNPSPECS.HTM>.
- *Clarification to Plug and Play ISA Specification*, Version 1.0a, <http://www.microsoft.com/hwdev/respec/PNPSPECS.HTM>.

PMM

- *POST Memory Manager Specification*, Version 1.01, <http://www.ptltd.com/techs/specs.html>.

Power Supply

- TBD

Regulatory

- *CISPR 22: Limits and Methods of Measurement of Radio Interference Characteristics of Information Technology Equipment*, 2nd Edition.
- *CFR 47: Federal Communications Commission (FCC) Compliance with the Class A Limits for Computing Devices (FCC Mark)*, Part 2 & 15.
- *ANSI C63.4: American National Standard for Methods of Measurement of Radio-Noise Emissions from Low Voltage Electronic Equipment in the Range of 9 kHz to 40 GHz for EMI Testing*, 1992.
- *CISPR 24: Information Technology Equipment - Immunity Characteristics Limits and Methods of Measurement*, 1st Edition.
- *ICES-003: Canadian Radio Interference Regulations for Digital Apparatus*.
- *EN 61000-3-2: Electromagnetic Compatibility (EMC) Part 3: Limits - Section 2: Limits for Harmonic Current Emissions*.
- *JEIDA MITI Guideline for Suppression of High Harmonics in Appliances and General-Use Equipment*.

SCSI

- *Adaptec* AIC-7899* Dual-Channel PCI-to-Ultra 320/M SCSI Single-Chip Host Adapter Specification*, <http://www.adaptec.com/>.

Server Management

- *Emergency Management Port v1.0 Interface External Product Specification*, Revision 0.83, Intel Corporation.
- *Intelligent Platform Management Interface (IPMI) Specification*, Version 1.0, Revision 1.1, Intel Corporation, <http://developer.intel.com/design/servers/ipmi/spec.htm>.

SMBIOS

- *System Management BIOS Reference Specification*, Version 2.3, <http://www.ptitd.com/techs/specs.html>.

Super I/O

- *National* PC97317* SuperI/O Plug and Play Compatible Chip with ACPI-Compliant Controller/Extender*, <http://www.national.com/pf/PC/PC97317.html>.

USB

- *Universal Serial Bus Specification*, Revision 2.0, <http://www.usb.org/developers>.

VGA

- *ATI* RAGE* IIC Technical Reference Manual*.
- *ATI-264 VT4* Graphics Controller Technical Reference Manual*.

Wired for Management

- *Wired for Management (WfM) Baseline Specifications*, Version 2.0, Intel Corporation, <http://developer.intel.com/ial/wfm/wfmspecs.htm>.

Windows

- *Hardware Design Guide for Microsoft® Windows NT Server**, Version 2.0, <http://www.microsoft.com/HWDEV/serverdg.htm>.

Miscellaneous

- *Intel Environmental Standards Handbook*, June 1999, Intel Document No. 662394-04.
- *VRM 8.3 DC-DC Converter Specification*.
- *VRM 8.4 DC-DC Converter Specification*.