

Hardware User's Guide

Intel[®] RAID Controller SRCU42E

June 2004

C76895-002

INFORMATION IN THIS DOCUMENT IS PROVIDED IN CONNECTION WITH INTEL(R) PRODUCTS. NO LICENSE, EXPRESS OR IMPLIED, BY ESTOPPEL OR OTHERWISE, TO ANY INTELLECTUAL PROPERTY RIGHTS IS GRANTED BY THIS DOCUMENT. EXCEPT AS PROVIDED IN INTEL'S TERMS AND CONDITIONS OF SALE FOR SUCH PRODUCTS, INTEL ASSUMES NO LIABILITY WHATSOEVER, AND INTEL DISCLAIMS ANY EXPRESS OR IMPLIED WARRANTY, RELATING TO SALE AND/OR USE OF INTEL PRODUCTS INCLUDING LIABILITY OR WARRANTIES RELATING TO FITNESS FOR A PARTICULAR PURPOSE, MERCHANTABILITY, OR INFRINGEMENT OF ANY PATENT, COPYRIGHT OR OTHER INTELLECTUAL PROPERTY RIGHT. Intel products are not intended for use in medical, life saving, life sustaining applications. Intel may make changes to specifications and product descriptions at any time, without notice.

Intel is a trademark or registered trademark of Intel Corporation or its subsidiaries in the United States and other countries.

*Other names and brands may be claimed as the property of others.

Copyright © 2004 by Intel Corporation. Portions Copyright 2003 - 2004 by LSI Logic Corporation. All rights reserved.

Safety Warnings

WARNING: English

Important Safety Instructions

Read all caution and safety statements in this document before performing any of the instructions. See also Intel Server Boards and Server Chassis Safety Information on the Resource CD and/or at <http://support.intel.com/support/motherboards/server/safecert.htm>.

	<p>SAFETY STEPS: Whenever you remove the chassis covers to access the inside of the system, follow these steps:</p> <ol style="list-style-type: none">1. Turn off all peripheral devices connected to the system.2. Turn off the system by pressing the power button.3. Unplug all AC power cords from the system or from wall outlets.4. Label and disconnect all cables connected to I/O connectors or ports on the back of the system.5. Provide some electrostatic discharge (ESD) protection by wearing an antistatic wrist strap attached to chassis ground of the system-any unpainted metal surface-when handling components.6. Do not operate the system with the chassis covers removed.
	<p>A microprocessor and heat sink may be hot if the system has been running. Also, there may be sharp pins and edges on some board and chassis parts. Contact should be made with care. Consider wearing protective gloves.</p>

ADVERTENCIAS: Español

Instrucciones de seguridad importantes

Lea todas las declaraciones de seguridad y precaución de este documento antes de realizar cualquiera de las instrucciones. Vea Intel Server Boards and Server Chassis Safety Information en el CD Resource y/o en <http://support.intel.com/support/motherboards/server/safecert.htm>.

	<p>INSTRUCCIONES DE SEGURIDAD: Cuando extraiga la tapa del chasis para acceder al interior del sistema, siga las siguientes instrucciones:</p> <ol style="list-style-type: none">1. Apague todos los dispositivos periféricos conectados al sistema.2. Apague el sistema presionando el interruptor encendido/apagado.3. Desconecte todos los cables de alimentación CA del sistema o de las tomas de corriente alterna.4. Identifique y desconecte todos los cables enchufados a los conectores E/S o a los puertos situados en la parte posterior del sistema.5. Cuando manipule los componentes, es importante protegerse contra la descarga electrostática (ESD). Puede hacerlo si utiliza una muñequera antiestática sujeta a la toma de tierra del chasis - o a cualquier tipo de superficie de metal sin pintar.6. No ponga en marcha el sistema si se han extraído las tapas del chasis.
	<p>Si el sistema ha estado en funcionamiento, el microprocesador y el disipador de calor pueden estar aún calientes. También conviene tener en cuenta que en el chasis o en el tablero puede haber piezas cortantes o punzantes. Por ello, se recomienda precaución y el uso de guantes protectores.</p>

WARNUNG: Deutsch
Wichtige Sicherheitshinweise

Lesen Sie zunächst sämtliche Warn- und Sicherheitshinweise in diesem Dokument, bevor Sie eine der Anweisungen ausführen. Beachten Sie hierzu auch die Sicherheitshinweise zu Intel-Serverplatinen und -Servergehäusen auf der Ressourcen-CD oder unter <http://support.intel.com/support/motherboards/server/safecert.htm>.

	<p>SICHERHEISSMASSNAHMEN: Immer wenn Sie die Gehäuseabdeckung abnehmen um an das Systeminnere zu gelangen, sollten Sie folgende Schritte beachten:</p> <ol style="list-style-type: none"> 1. Schalten Sie alle an Ihr System angeschlossenen Peripheriegeräte aus. 2. Schalten Sie das System mit dem Hauptschalter aus. 3. Ziehen Sie den Stromanschlußstecker Ihres Systems aus der Steckdose. 4. Auf der Rückseite des Systems beschriften und ziehen Sie alle Anschlußkabel von den I/O Anschlüssen oder Ports ab. 5. Tragen Sie ein geerdetes Antistatik Gelenkband, um elektrostatische Ladungen (ESD) über blanke Metallstellen bei der Handhabung der Komponenten zu vermeiden. 6. Schalten Sie das System niemals ohne ordnungsgemäß montiertes Gehäuse ein.
	<p>Der Mikroprozessor und der Kühler sind möglicherweise erhitzt, wenn das System in Betrieb ist. Außerdem können einige Platinen und Gehäuseteile scharfe Spitzen und Kanten aufweisen. Arbeiten an Platinen und Gehäuse sollten vorsichtig ausgeführt werden. Sie sollten Schutzhandschuhe tragen.</p>

Der Mikroprozessor und der Kühler sind möglicherweise erhitzt, wenn das System in Betrieb ist. Außerdem können einige Platinen und Gehäuseteile scharfe Spitzen und Kanten aufweisen. Arbeiten an Platinen und Gehäuse sollten vorsichtig ausgeführt werden. Sie sollten Schutzhandschuhe tragen.

AVERTISSEMENT: Français
Consignes de sécurité

Lisez attention toutes les consignes de sécurité et les mises en garde indiquées dans ce document avant de suivre toute instruction. Consultez Intel Server Boards and Server Chassis Safety Information sur le CD Resource CD ou bien rendez-vous sur le site <http://support.intel.com/support/motherboards/server/safecert.htm>.

	<p>CONSIGNES DE SÉCURITÉ: Lorsque vous ouvrez le boîtier pour accéder à l'intérieur du système, suivez les consignes suivantes:</p> <ol style="list-style-type: none"> 1. Mettez hors tension tous les périphériques connectés au système. 2. Mettez le système hors tension en mettant l'interrupteur général en position OFF (bouton-poussoir). 3. Débranchez tous les cordons d'alimentation c.a. du système et des prises murales. 4. Identifiez et débranchez tous les câbles reliés aux connecteurs d'E-S ou aux accès derrière le système. 5. Pour prévenir les décharges électrostatiques lorsque vous touchez aux composants, portez une bande antistatique pour poignet et reliez-la à la masse du système (toute surface métallique non peinte du boîtier). 6. Ne faites pas fonctionner le système tandis que le boîtier est ouvert.
	<p>Le microprocesseur et le dissipateur de chaleur peuvent être chauds si le système a été sous tension. Faites également attention aux broches aiguës des cartes et aux bords tranchants du capot. Nous vous recommandons l'usage de gants de protection.</p>

AVVERTENZA: Italiano

	<p>PASSI DI SICUREZZA: Qualora si rimuovano le coperture del telaio per accedere all'interno del sistema, seguire i seguenti passi:</p> <ol style="list-style-type: none">1. Spegner tutti i dispositivi periferici collegati al sistema.2. Spegner il sistema, usando il pulsante spento/acceso dell'interruttore del sistema.3. Togliere tutte le spine dei cavi del sistema dalle prese elettriche.4. Identificare e sconnettere tutti i cavi attaccati ai collegamenti I/O od alle prese installate sul retro del sistema.5. Qualora si tocchino i componenti, proteggersi dallo scarico elettrostatico (SES), portando un cinghia anti-statica da polso che è attaccata alla presa a terra del telaio del sistema - qualsiasi superficie non dipinta - .6. Non far operare il sistema quando il telaio è senza le coperture.
	<p>Se il sistema è stato a lungo in funzione, il microprocessore e il dissipatore di calore potrebbero essere surriscaldati. Fare attenzione alla presenza di piedini appuntiti e parti taglienti sulle schede e sul telaio. È consigliabile l'uso di guanti di protezione.</p>

Regulatory and Certification Information

Product Regulatory Compliance

This RAID Controller Card complies with the following safety and electromagnetic compatibility (EMC) regulations.

Product Safety Compliance

- UL 1950 - CSA 950 (US/Canada)
- EN 60 950 (European Union)
- IEC60 950 (International)
- CE - Low Voltage Directive (73/23/EEC) (European Union)









Product EMC Compliance - Class B

- FCC /ICES-003 (USA/Canada)
- CISPR 22 (International)
- EN55022 (Europe)
- EN55024 (Europe)
- CE - EMC Directive 89/336/EEC (Europe)
- VCCI (Japan)
- AS/NZS 3548 (Australia / New Zealand)
- BSMI CNS13438 (Taiwan)
- RRL, MIC Notice No. 1997-41 (EMC) & 1997-42 (EMI) (Korea)

Product Regulatory Compliance Markings

The RAID Controller Card is marked with the following compliance markings. Some marking information may be provided on the packaging and/or in the product documentation due to limited marking space on the product.

- ETL NRTL Mark (US/Canada)
- FCC Mark (US)
- ICES-003 (Canada)
- CE Mark (Europe)
- VCCI Mark (Japan)
- MIC Mark (Korea)
- BSMI DOC Mark (Taiwan)
- ACS C-Tick Mark (Australia)

Regulatory Compliance	Country	Marking
cULus Listing Marks	USA/Canada	
ETL (NRTL) Mark	USA/Canada	
CE Mark	Europe	
FCC Marking (Class A)	USA	This device complies with Part 15 of the FCC Rules. Operation of this device is subject to the following two conditions: (1) This device may not cause harmful interference, and (2) This device must accept any interference received, including interference that may cause undesired operation.
FCC Marking (Class B)	USA	 Tested to Comply With FCC standards FOR HOME OR OFFICE USE
EMC Marking (Class A)	Canada	CANADA ICES-003 CLASS A CANADA NMB-003 CLASSE A
EMC Marking (Class B)	Canada	CANADA ICES-003 CLASS B CANADA NMB-003 CLASSE B
VCCI Marking (Class A)	Japan	<div style="border: 1px solid black; padding: 5px;">この装置は、情報処理装置等電波障害自主規制協議会（VCCI）の基準に基づくクラスA情報技術装置です。この装置を家庭環境で使用すると電波妨害を引き起こすことがあります。この場合には使用者が適切な対策を講ずるよう要求されることがあります。</div>
VCCI Marking (Class B)	Japan	<div style="border: 1px solid black; padding: 5px;">この装置は、情報処理装置等電波障害自主規制協議会（VCCI）の基準に基づくクラスB情報技術装置です。この装置は、家庭環境で使用することを目的としています。この装置がラジオやテレビジョン受信機に近接して使用されると、受信障害を引き起こすことがあります。 取扱説明書に従って正しい取り扱いをして下さい。</div> 
BSMI Marking (Class A or B) and Class A EMC Warning	Taiwan	 <div style="border: 1px solid black; padding: 5px;">警告使用者： 這是甲類的資訊產品，在居住的環境中使用時，可能會造成射頻干擾，在這種情況下，使用者會被要求採取某些適當的對策</div>
RRL MIC Mark	Korea	
C-Tick Mark	Australia	

Electromagnetic Compatibility Notices

FCC Verification Statement (USA)

This device complies with Part 15 of the FCC Rules. Operation is subject to the following two conditions: (1) This device may not cause harmful interference, and (2) this device must accept any interference received, including interference that may cause undesired operation.

Intel Corporation
5200 N.E. Elam Young Parkway
Hillsboro, OR 97124-6497
Phone: 1-800-628-8686

This equipment has been tested and found to comply with the limits for a Class B digital device, pursuant to Part 15 of the FCC Rules. These limits are designed to provide reasonable protection against harmful interference in a residential installation. This equipment generates, uses, and can radiate radio frequency energy and, if not installed and used in accordance with the instructions, may cause harmful interference to radio communications. However, there is no guarantee that interference will not occur in a particular installation. If this equipment does cause harmful interference to radio or television reception, which can be determined by turning the equipment off and on, the user is encouraged to try to correct the interference by one or more of the following measures:

- Reorient or relocate the receiving antenna.
- Increase the separation between the equipment and the receiver.
- Connect the equipment into an outlet on a circuit different from that to which the receiver is connected.
- Consult the dealer or an experienced radio/TV technician for help.

Intel is not responsible for any radio or television interference caused by unauthorized modification of this equipment for substitution or attachment of connecting cables and equipment other than those specified by Intel. The correction of interferences caused by such unauthorized modification, substitution, or attachment will be the responsibility of the user.

This RAID Controller Card has been tested to comply with FCC Standards for home or office use.

ICES-003 (Canada)

This digital apparatus does not exceed the Class B limits for radio noise emissions from digital apparatus set out in the interference-causing equipment standard entitled "Digital Apparatus," ICES-003 of the Canadian Department of Communications.

Cet appareil numérique respecte les limites bruits radioélectriques applicables aux appareils numériques de Classe Aprescrites dans la norme sur le matériel brouilleur: "Appareils Numériques", NMB-003 édictée par le Ministre Canadien des Communications.

Europe (CE Declaration of Conformity)

This product has been tested in accordance too, and complies with the Low Voltage Directive (73/23/EEC) and EMC Directive (89/336/EEC). The product has been marked with the CE Mark to illustrate its compliance.

RRL (Korea)

English translation of the notice above:

1. Type of Equipment (Model Name): Model name on product
2. Certification No.: On RRL certificate. Obtain certificate from local Intel representative
3. Name of Certification Recipient: LSI Logic Corporation
4. Date of Manufacturer: Refer to date code on product
5. Manufacturer/Nation: LSI Logic Corporation / Refer to country of origin marked on product

Preface

This guide is the hardware reference and user's guide for the Intel® RAID Controller SRCU42E. It contains complete installation instructions and specifications .

For information about how to configure the RAID Controller SRCU42E, and for an overview of the software drivers, see the *Intel RAID Software User's Guide*.

Audience

This document assumes that you have some familiarity with RAID controllers and related support devices. The people who benefit from this book are:

- Engineers who are designing an RAID Controller SRCU42E into a system
- Anyone installing an RAID Controller SRCU42E in their RAID system

Organization

This document has the following chapters and appendixes:

- Chapter 1, "Overview," provides a general overview of the RAID Controller SRCU42E.
- Chapter 2, "Hardware Installation," describes the procedures for installing the RAID Controller SRCU42E.
- Chapter 3, "Intel® RAID Controller SRCU42E Technical Reference," describes the technical specifications for the RAID Controller SRCU42E.
- Chapter A, "Glossary of Terms and Abbreviations," lists and explains the terms and abbreviations used in this manual.

Related Publications

Intel® RAID Software User's Guide on the Resource CD included with the RAID controller.

Safety Instructions

Use the following safety guidelines to help protect your computer system from potential damage and to ensure your own personal safety.

When Using Your Computer System

As you use your computer system, observe the following safety guidelines:

CAUTION: Do not operate your computer system with any cover(s) (such as computer covers, bezels, filler brackets, and front-panel inserts) removed:

- To help avoid damaging your computer, be sure the voltage selection switch on the power supply is set to match the alternating current (AC) power available at your location:
 - 115 volts (V)/60 hertz (Hz) in most of North and South America and some Far Eastern countries such as Japan, South Korea, and Taiwan
 - 230 V/50 Hz in most of Europe, the Middle East, and the Far East. Also be sure your monitor and attached peripherals are electrically rated to operate with the AC power available in your location.
- To help avoid possible damage to the system board, wait five seconds after turning off the system before removing a component from the system board or disconnecting a peripheral device from the computer.
- To help prevent electric shock, plug the computer and peripheral power cables into properly grounded power sources. These cables are equipped with 3-prong plugs to ensure proper grounding. Do not use adapter plugs or remove the grounding prong from a cable. If you must use an extension cable, use a 3-wire cable with properly grounded plugs.
- To help protect your computer system from sudden, transient increases and decreases in electrical power, use a surge suppressor, line conditioner, or uninterruptible power supply.
- Be sure nothing rests on your computer system's cables and that the cables are not located where they can be stepped on or tripped over.
- Do not spill food or liquids on your computer. If the computer gets wet, consult the documentation that came with it.
- Do not push any objects into the openings of your computer. Doing so can cause fire or electric shock by shorting out interior components.
- Keep your computer away from radiators and heat sources. Also, do not block cooling vents. Avoid placing loose papers underneath your computer; do not place your computer in a closed-in wall unit or on a rug.

When Working Inside Your Computer

Notice: Do not attempt to service the computer system yourself, except as explained in this guide and elsewhere in Intel documentation. Always follow installation and service instructions closely.

1. Turn off your computer and any peripherals.
2. Disconnect your computer and peripherals from their power sources. Also disconnect any telephone or telecommunications lines from the computer.

Doing so reduces the potential for personal injury or shock.

Also note these safety guidelines:

- When you disconnect a cable, pull on its connector or on its strain-relief loop, not on the cable itself. Some cables have a connector with locking tabs; if you are disconnecting this type of cable, press in on the locking tabs before disconnect the cable. As you pull connectors apart, keep them evenly aligned to avoid bending any connector pins. Also, before you connect a cable, make sure both connectors are correctly oriented and aligned.
- Handle components and cards with care. Don't touch the components or contacts on a card. Hold a card by its edges or by its metal mounting bracket. Hold a component such as a microprocessor chip by its edges, not by its pins.

Protecting Against Electrostatic Discharge

Static electricity can harm delicate components inside your computer. To prevent static damage, discharge static electricity from your body before you touch any of your computer's electronic components, such as the microprocessor. You can do so by touching an unpainted metal surface, such as the metal around the card-slot openings at the back of the computer.

As you continue to work inside the computer, periodically touch an unpainted metal surface to remove any static charge your body may have accumulated. In addition to the preceding precautions, you can also take the following steps to prevent damage from electrostatic discharge (ESD):

- When unpacking a static-sensitive component from its shipping carton, do not remove the component from the antistatic packing material until you are ready to install the component in your computer. Just before unwrapping the antistatic packaging, be sure to discharge static electricity from your body.
- When transporting a sensitive component, first place it in an antistatic container or packaging.
- Handle all sensitive components in a static-safe area. If possible, use antistatic floor pads and workbench pads.

Contents

Chapter 1 Overview

1.1	Overview	15
1.2	Features	16
1.3	Hardware	17
1.3.1	RAID Controller Configurations	17
1.3.2	Configuration on Disk	18
1.3.3	Drive Roaming	18

Chapter 2 Hardware Installation

2.1	Requirements	19
2.2	Quick Installation	20
2.3	Detailed Installation	20
2.4	After You Have Installed the RAID Controller	25

Chapter 3 Intel® RAID Controller SRCU42E Technical Reference

3.1	Overview	26
3.2	Intel® RAID Controller SRCU42E Characteristics	28
3.3	Technical Specifications	28
3.3.1	RAID Controller Specifications	28
3.3.2	Array Performance Features	29
3.3.3	Fault Tolerance	30
3.3.4	Electrical Characteristics	30
3.3.5	Thermal and Atmospheric Characteristics	30
3.3.6	Safety Characteristics	31

Chapter A Glossary of Terms and Abbreviations

Figures

2.1	Install the Intel Portable Cache Module	21
2.2	Inserting the Intel [®] RAID Controller SRCU42E in a x8 PCI Express* Slot22	
2.3	Terminating an Internal SCSI Disk Array.	24
3.1	Intel [®] RAID Controller SRCU42E Layout.	26

Tables

1-1	Intel® Raid Controller SRCU42E Features	17
2-1	Target ID's	22
3-1	Intel® RAID Controller SRCU42E Headers and Connectors .	27
3-2	Intel® RAID Controller SRCU42E Characteristics	28
3-3	Intel® RAID Controller SRCU42E Specifications	28
3-4	Array Performance Features	29
3-5	Fault Tolerance Features	30
3-6	Maximum Power Requirements	30

Chapter 1

Overview

This section provides a general overview of the Intel® RAID Controller SRCU42E . It consists of the following sections.

- Section 1.1, “Overview,” page 15
 - Section 1.2, “Features,” page 16
 - Section 1.3, “Hardware,” page 17
-

1.1 Overview

The Intel® RAID Controller SRCU42E is a high-performance intelligent PCI Express* host adapter with Redundant Array of Independent Disks (RAID) control capabilities. The RAID Controller SRCU42E provides reliability, high performance, and fault-tolerant disk subsystem management. It is an ideal RAID solution for the internal storage of workgroup, departmental, and enterprise systems. The RAID controller offers a cost-effective way to implement RAID in a server.

The RAID Controller SRCU42E (dual-channel) is a PCI Express* controller that has one LSI* 53C1030 controller chip that controls two SCSI channels. The RAID controller has two VHDCI 68-pin external SCSI connectors and two HDCI 68-pin internal SCSI connectors.

The RAID Controller SRCU42E supports a low voltage differential (LVD) or a single-ended (SE) SCSI bus. With LVD, you can use cables up to 12 meters long. Throughput on each SCSI channel can be as high as 320 Mbytes/s.

You can install the Intel® RAID Controller SRCU42E in PCI-Express computer systems with a standard bracket type. With this RAID controller in your PCI-Express system, you can connect SCSI devices over a SCSI bus.

For Ultra320 SCSI performance, you must connect only LVD devices to the bus. Do not mix SE with LVD devices, or the bus speed will be limited to the slower SE (Ultra SCSI) SCSI data transfer rates. Do not connect a high voltage differential (HVD) device.

The Intel® RAID Controller SRCU42E supports major operating systems, such as Microsoft* Windows* XP, Microsoft* Windows* 2000, Microsoft* Windows Server* 2003, Novell* NetWare*, Red Hat* Linux*, and SuSE* Linux*.

Note: The operating systems supported by this controller may not be supported by your server board. Please refer to the tested OS list for your server board at <http://support.intel.com/support/motherboards/server/>. See also the tested hardware and operating system list for the RAID Controller SRCU42E to make sure the RAID controller supports your operating system.

1.2 Features

Features of the Intel® RAID Controller SRCU42E include:

- Support for hard disk drives with capacities greater than 8 Gbytes
- Online RAID level migration
- RAID remapping
- No reboot necessary after expansion (for NT 4.0: if virtual sizing is enabled)
- More than 200 Qtags per array
- Hardware clustering support on the board
- User-specified rebuild rate
- Wide Ultra320 LVD SCSI performance up to 320 Mbytes/s
- Support for up to 512 Mbyte of double data rate (DDR1) ECC PC2700 DDR333 DIMM: one 128-, 256-, or 512-Mbyte DIMM can be installed.
- Support for a x8 PCI Express interface.
- The RAID Controller SRCU42E has two internal and two external SCSI connectors
- Support for RAID levels 0 (striping), 1 (mirroring), 5 (striping and parity data across all drives), 10 (mirroring and striping), and 50 (RAID 5 and striping)
- Advanced array configuration and management utilities
- Battery backup for up to 72 hours with the 128 Mbyte Intel® Portable Cache Module
- Support for up to 14 SCSI drives per channel on storage system with SAF-TE enclosures (SCSI accessed fault-tolerant enclosures): 15 SCSI drives per channel for other configurations.
- 32 Kbyte NVRAM for storing RAID system configuration information; the firmware is stored in flash ROM for easy upgrade

1.3 Hardware

You can install the Intel® RAID Controller SRCU42E in a computer with a system board that has a x8 or x16 PCI Express slot.

The following subsections describe the hardware configuration and configuration-on-disk.

1.3.1 RAID Controller Configurations

Table 1-1 describes the features of the RAID Controller SRCU42E.

Table 1-1 Intel® Raid Controller SRCU42E Features

Feature	Description
RAID Levels	0, 1, 5, 10, 50
SCSI Device Types	Synchronous or Asynchronous
Devices per SCSI Channel	Up to 15 Wide SCSI devices
SCSI Channels	2
SCSI Data Transfer Rate	Up to 320 Mbytes/s per channel
SCSI Bus	LVD or SE
Cache Function	Write-back (requires Portable Cache Module), Write-through, Adaptive Read Ahead, Non Read Ahead, Read Ahead, Cache I/O, Direct I/O
Multiple Logical Drives/Arrays per Controller	Up to 40 logical drives per controller
Online Capacity Expansion	Yes
Dedicated and Pool Hot Spare	Yes
Hot Swap Devices Supported	Yes
Non-Disk Devices Supported	Yes
Mixed Capacity Hard Disk Drives	Yes
Number of 16-bit Internal Connectors	2
Number of 16-bit External Connectors	2
Cluster Support	Yes
Hardware Exclusive OR (XOR) Assistance	Yes
Direct I/O	Yes
Architecture	Fusion-MPT™

1.3.2 Configuration on Disk

Configuration on Disk saves configuration information both in NVRAM on the Intel® RAID Controller SRCU42E and on the disk drives attached to the RAID Controller SRCU42E. If the RAID Controller SRCU42E is replaced, the new RAID Controller SRCU42E detects the actual RAID configuration from the configuration information on the drives. This maintains the integrity of the data on each drive, even if the drives have changed their target ID.

Note: Configuration on Disk does not work if you change both the RAID Controller SRCU42E and the SCSI connectors to different connectors on the new RAID controller. It works only if you make one change at a time.

1.3.3 Drive Roaming

The RAID Controller SRCU42E supports drive roaming across channels on the same RAID Controller SRCU42E. Drive roaming lets an Intel Raid RAID Controller SRCU42E detect the actual RAID configuration, maintaining the integrity of the data on each disk drive, even if the disk drives have changed channels and/or target ID.

Note: The RAID Controller SRCU42E does not support drive roaming across channels when cluster mode is enabled.

Chapter 2

Hardware Installation

This chapter describes the procedures for installing the Intel® RAID Controller SRCU42E. It contains the following sections:

- Section 2.1, “Requirements,” page 19
 - Section 2.2, “Quick Installation,” page 20
 - Section 2.3, “Detailed Installation,” page 20
 - Section 2.4, “After You Have Installed the RAID Controller,” page 25
-

2.1 Requirements

The following items are required to install the RAID controller:

- An Intel® RAID Controller SRCU42E
- A host computer with an available x8 PCI Express* expansion slot
- The Resource CD
- The necessary internal and/or external SCSI cables. Ensure that the SCSI cables conform to all SCSI specifications.
- Ultra, Ultra2, Ultra160, or Ultra320 SCSI hard disk drives (although backward compatible, SCSI uses the speed of the slowest device on the bus)
- The Intel® Portable Cache Module (optional) or one 128-, 256-, or 512-Mbyte 200 MHz DDR1 ECC PC2700 DDR333 memory DIMM (your RAID Controller SRCU42E may come with a 128 Mbyte DIMM pre-installed)

Intel strongly recommends using an uninterruptible power supply (UPS).

2.2 Quick Installation

The following steps are for for experienced computer users/installers. Section 2.3, “Detailed Installation”, contains detailed steps.

- 1) Attach the Intel® Portable Cache Module (Optional, required to enable Write Back Cache) or attach the memory DIMM to the RAID controller if the DIMM is not pre-installed.
- 2) Turn power off to the server and all hard disk drives, enclosures, and system components and remove the PC power cord.
- 3) Follow the instructions in the host system documentation to open the cabinet of the host system.
- 4) Determine the SCSI ID and SCSI termination requirements.
- 5) Install the RAID Controller SRCU42E in the server, connect SCSI devices to it, and set termination correctly on the SCSI channel(s).
- 6) Perform a safety check:
 - Ensure that all cables are properly attached.
 - Ensure that the RAID Controller SRCU42E is properly installed.
 - Close the cabinet of the host system.
- 7) Turn power on after completing the safety check.

2.3 Detailed Installation

This section provides detailed instructions for installing the Intel® RAID Controller SRCU42E.

1) Unpack

Unpack and remove the RAID Controller SRCU42E. Inspect it for damage. If it appears damaged, or if any items listed below are missing, contact your Intel support representative. The Intel® RAID Controller SRCU42E is shipped with:

- ◇ The Resource CD, which contains Intel RAID drivers for supported operating systems, an electronic version of this guide, and other related documentation.
- ◇ A license agreement

- 2) Attach the Intel® Portable Cache Module (Optional, required to enable Write Back Cache) or attach the memory DIMM to the controller if the DIMM is not pre-installed.
 - a. Remove the Intel® Portable Cache Module or memory DIMM from its packaging.
 - b. Open both DIMM socket levers on the RAID controller, noted by letter B in the figure below.
 - c. Note the location of the alignment notch and insert the Intel® Portable Cache Module or memory DIMM, lining up the slot in the Intel® Portable Cache Module or DIMM with the alignment notch.
 - d. Push the Intel® Portable Cache Module or DIMM firmly into the card. See letter A in Figure 2.1.
 - e. Make sure the socket levers latch securely.

- f. Intel® Portable Cache Module only: Insert the screw included with the Intel® Portable Cache Module from the back of the Intel® RAID Controller SRCU42E into the bracket on the Intel® Portable Cache Module.

Figure 2.1 Install the Intel Portable Cache Module

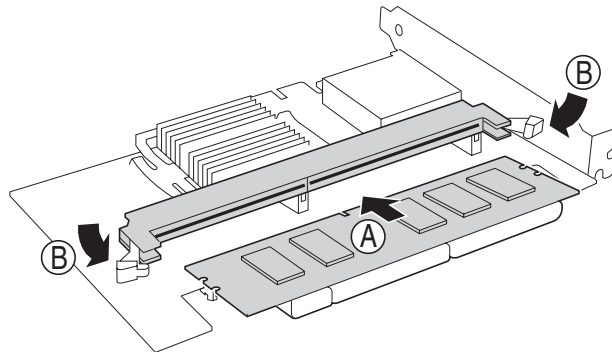

TP00749

3) Power Down the System

Turn off the computer and remove the AC power cord. Remove the system's cover. See your system documentation for instructions.

4) Check the Jumpers

Ensure that the jumper settings on the your RAID Controller SRCU42E are correct. See Chapter 3, "Intel® RAID Controller SRCU42E Technical Reference," for diagrams of the RAID Controller SRCU42Es with their jumpers and connectors.

5) Install the Intel® RAID Controller SRCU42E

Select a x8 PCI Express slot, and align the RAID Controller SRCU42E PCI bus connector to the slot. Press down gently but firmly to ensure that the card is properly seated in the slot, as shown in Figure 2.2. Then screw the bracket into the computer chassis.

Figure 2.2 Inserting the Intel® RAID Controller SRCU42E in a x8 PCI Express* Slot

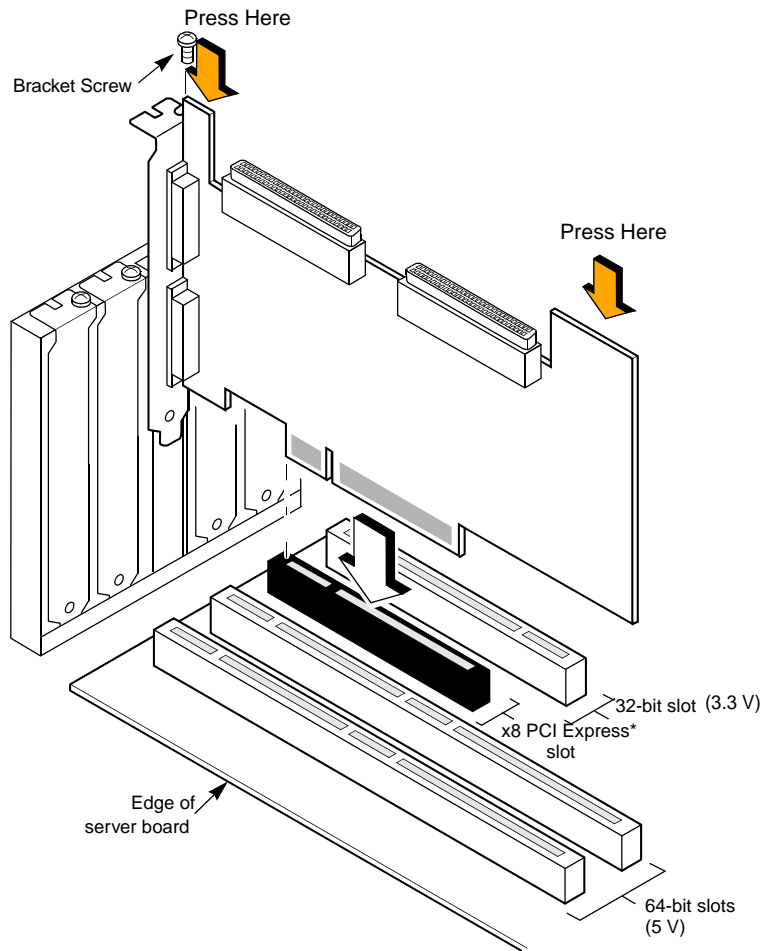

6) Set the Target IDs.

Set target identifiers (TIDs) on the SCSI devices. Each device in a channel must have a unique TID. Provide unique TIDs for non-disk devices (CD-ROM or tapes), regardless of the channel where they are connected. The Intel® RAID Controller SRCU42E automatically occupies TID 7, which is the highest priority. The arbitration priority for a SCSI device depends on its TID.

Table 2-1 Target ID's

Priority	Highest						Lowest					
TID	7	6	5	...	2	1	0	15	14	...	9	8

7) Connect SCSI devices to the Intel® RAID Controller SRCU42E.

Use SCSI cables to connect SCSI devices to the RAID Controller SRCU42E.

To connect the SCSI devices:

- a. Disable termination on any SCSI device that does not sit at the end of the SCSI bus.
- b. Configure all SCSI devices to supply TERMPWR.
- c. Connect cables to the SCSI devices. The maximum cable length for Fast SCSI (10 Mbytes/s) devices or SE is 3 meters; it is 1.5 meters for Ultra SCSI devices; it is 12 meters for LVD devices. You can connect up to 15 Ultra SCSI devices to each SCSI channel.

System throughput problems can occur if SCSI cables are not the correct type. To minimize the potential for problems:

- Use cables no longer than 12 meters for Ultra160 and Ultra320 devices.
- For SE SCSI devices, use the shortest SCSI cables (no longer than 3 meters for Fast SCSI, no longer than 1.5 meters for an 8-drive Ultra SCSI system, and no longer than 3 meters for a 6-drive Ultra SCSI system).
- Use active termination.
- Avoid clustering the cable nodes.
- The cable stub length must be no greater than 0.1 meter (4 inches.)
- Use high impedance cables.
- Route SCSI cables carefully.

8) Set SCSI Termination

The SCSI bus is an electrical transmission line and must be terminated properly to minimize reflections and losses. Set termination at each end of the SCSI cable(s).

For a disk array, set SCSI bus termination so that removing or adding a SCSI device does not disturb termination. An easy way to do this is to connect the RAID Controller SRCU42E to one end of the SCSI cable and to connect an external terminator module at the other end of the cable. You can then connect SCSI disk drives to the connectors between the two ends of the cable. If necessary, disable termination on the SCSI devices. (This is not necessary for Ultra320 and Ultra160 SCSI drives.)

Set the termination so that SCSI termination and TermPWR are intact when any disk drive is removed from a SCSI channel, as shown in Figure 2.3.

Figure 2.3 Terminating an Internal SCSI Disk Array

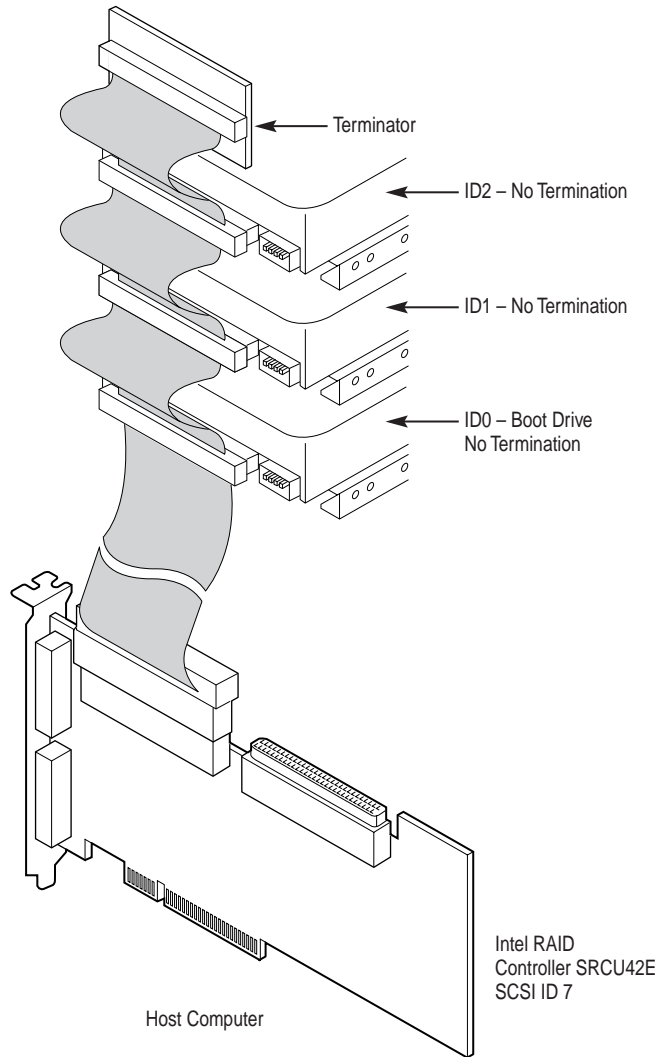

9) Power On Host System

Replace the computer cover, and reconnect the AC power cords. Turn power on to the host computer. Ensure that the SCSI devices are powered up at the same time as, or before, the host computer. If the computer is powered up before a SCSI device, the device might not be recognized.

During boot, a BIOS message appears.

The firmware takes several seconds to initialize. During this time, the RAID Controller SRCU42E scans the SCSI channel(s).

The BIOS Configuration utility prompt times out after several seconds. The second portion of the BIOS message displays the Intel® RAID Controller SRCU42E number, firmware version, and cache SDRAM size. The numbering of the controllers follows the PCI slot scanning order used by the host system board.

Press <CTRL><G> to run BIOS Console

2.4 After You Have Installed the RAID Controller

After installation, you must configure the RAID Controller SRCU42E and install the operating system driver. The *Intel RAID Software User's Guide* instructs you about the configuration options and how to set them on your RAID Controller SRCU42E.

Chapter 3

Intel® RAID Controller SRCU42E Technical Reference

This chapter describes the characteristics of the Intel® RAID Controller SRCU42E. This chapter contains the following sections:

- Section 3.1, “Overview,” page 26
- Section 3.2, “Intel® RAID Controller SRCU42E Characteristics,” page 28
- Section 3.3, “Technical Specifications,” page 28

3.1 Overview

The Intel® RAID Controller SRCU42E is used in systems that have a x8 PCI Express* slot with a PCI-standard bracket type.

PCI Express goes beyond the PCI specification in that it is intended as a unifying I/O architecture for a variety of systems, including desktops, workstations, mobile, server, communications, and embedded devices.

Figure 3.1 Intel® RAID Controller SRCU42E Layout

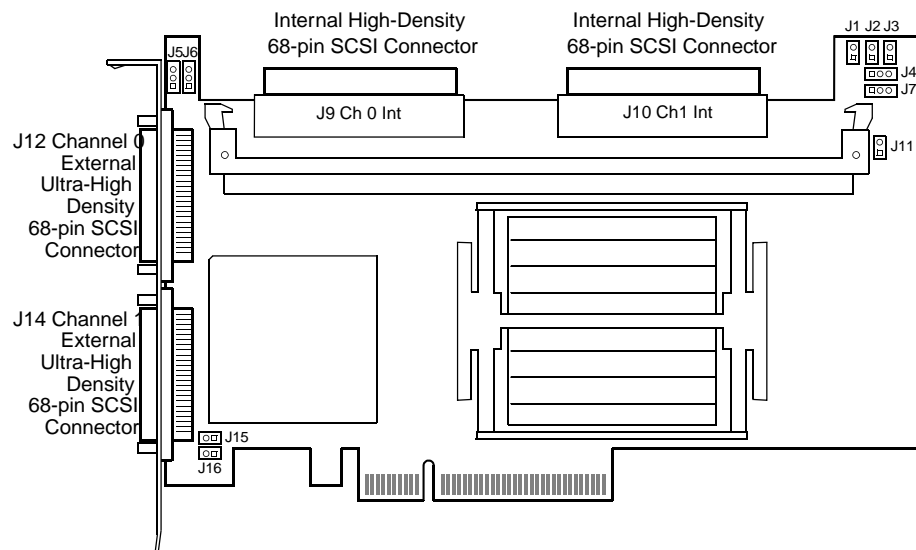

Table 3-1 Intel® RAID Controller SRCU42E Headers and Connectors

Connector	Description	Type	Comments
J1	Write Pending Indicator (Dirty Cache LED)	2-pin header	Connector for enclosure LED to indicate when data in the cache has yet to be written to the device. Optional.
J2	Onboard BIOS Enable	2-pin header	No jumper = Enabled (Default setting) Jumpered = Disabled
J3	SCSI Activity	2-pin header	Connector for enclosure LED to indicate data transfers.
J4	I ² C Header	3-pin connector	Reserved
J5	SCSI Termination Enable Channel 0	3-pin connector	Jumper pins 1-2 to enable software control of SCSI termination via drive detection.
J6	SCSI Termination Enable Channel 1	3-pin connector	Jumper pins 2-3 to disable onboard SCSI termination. No jumper installed enables onboard SCSI termination. (See J17 and J18). This is the default.
J7	Serial Port (RS232)	3-pin header	Connector is for diagnostic purposes. Pin-1 RXD (Receive Data) Pin-2 TXD (Transmit Data) Pin-3 GND (Ground)
J9	Internal SCSI Channel 0 connector	68-pin header	Internal high-density SCSI bus connector. Connection is optional.
J10	Internal SCSI Channel 1 connector	68-pin header	Internal high-density SCSI bus connector. Connection is optional.
J11	Mode Select	2-pin connector	Reserved
J12	External SCSI Channel 0 connector	68-pin header	External very-high density SCSI bus connector. Connection is optional.
J14	External SCSI Channel 1 connector	68-pin header	External very-high density SCSI bus connector. Connection is optional.
J15	Termination Power	2-pin connector	
J16	Termination Power	2-pin connector	

3.2 Intel® RAID Controller SRCU42E Characteristics

Table 3-2 shows the general characteristics for the RAID Controller SRCU42E .

Table 3-2 Intel® RAID Controller SRCU42E Characteristics

Flash ROM ¹	Serial EEPROM	LVD/SE Signaling	Ultra320 SCSI Data Transfers	SCSI Features	SCSI Termination
Yes	Yes	16-bit SE or LVD interfaces	Up to 320 Mbytes/s as well as Fast, Ultra, Ultra2, and Ultra160 speeds; Synchronous offsets up to 62.	Plug n Play Scatter/Gather Activity LED	Active: Single Ended or LVD

1. For boot code and firmware

3.3 Technical Specifications

The design and implementation of the RAID Controller SRCU42E minimizes electromagnetic emissions, susceptibility to radio frequency energy, and the effects of electrostatic discharge. The RAID Controller SRCU42E carries the CE mark, C-Tick mark, FCC Self-Certification logo, Canadian Compliance Statement, Korean MIC, Taiwan BSMI, and Japan VCCI, and they meet the requirements of CISPR Class B.

3.3.1 RAID Controller Specifications

Table 3-3 lists the specifications for the RAID Controller SRCU42E .

Table 3-3 Intel® RAID Controller SRCU42E Specifications

Specification	Description
Processor (PCI Controller)	Intel® 80332 I/O processor @ 500 MHz
Operating Voltage	3.3 V, +12 V
Card Size	Half-length PCI RAID controller size (6.875" X 4.2")
Array Interface to Host	x8 PCI Express*
PCI Bus Data Transfer Rate	x8 PCI Express host data transfer rate
Serial Port	3-pin RS232C-compatible connector (for manufacturing use only)
SCSI Controller(s)	One LSI* 53C1030 Dual SCSI controller
SCSI Connectors	Two 68-pin internal high-density connectors for SCSI devices. Two very high-density 68-pin external connectors for Ultra320 and Wide SCSI.
SCSI Bus Termination	Active: single-ended or LVD
Termination Disable	Automatic through cable and device detection

Table 3-3 Intel® RAID Controller SRCU42E Specifications (Cont.)

Specification	Description
Cache Configuration	128-, 256-, or 512 Mbyte DDR1 ECC PC2700 DDR333
Double-Sided Dual Inline Memory Modules (DIMMs)	Yes
Size of Flash ROM for Firmware	1 Mbyte flash ROM
Nonvolatile Random Access Memory (RAM)	32 Kbyte for storing RAID configuration

3.3.2 Array Performance Features

Table 3-4 shows the RAID Controller SRCU42E array performance features:

Table 3-4 Array Performance Features

Specification	Intel RAID Controller SRCU42E
x8 PCI Express Host Data Transfer Rate	2 Gbytes/second full duplex (4 Gbyte/second total) theoretical
Drive Data Transfer Rate	320 Mbytes/second per SCSI channel
Maximum Scatter/Gathers	26 elements
Maximum Size of I/O Requests	6.4 Mbytes in 64 Kbyte stripes
Maximum Queue Tags per Drive	As many as the drive can accept
Stripe Sizes	2, 4, 8, 16, 32, 64, or 128 Kbyte
Maximum Number of Concurrent Commands	255
Support for Multiple Initiators	Yes

3.3.3 Fault Tolerance

Table 3-5 shows the RAID Controller SRCU42E fault tolerance features:

Table 3-5 Fault Tolerance Features

Specification	Intel RAID Controller SRCU42E
Support for SMART ¹	Yes
Optional Battery Backup for Cache Memory	Yes. Up to 72 hours of data retention for 128 Mbyte
Drive Failure Detection	Automatic
Drive Rebuild Using Hot Spares	Automatic
Parity Generation and Checking	Yes

1. The Self Monitoring Analysis and Reporting Technology (SMART) detects up to 70 percent of all predictable disk drive failures. SMART also monitors the internal performance of all motors, heads, and drive electronics.

3.3.4 Electrical Characteristics

This section provides the power requirements for the Intel[®] RAID Controller SRCU42E. Table 3-6 lists the maximum power requirements, which include SCSI TERMPWR, under normal operation.

Table 3-6 Maximum Power Requirements

RAID Controller	PCI Express +3.3 V	PCI Express 12 V	PCI PRSNT1#/ PRSNT2# Power	Over the Operating Range
Intel [®] RAID Controller SRCU42E	1.5 A	1.4 A without battery 1.6 A when battery is charging	25 W	0 °C to 55 °C

3.3.5 Thermal and Atmospheric Characteristics

The Intel[®] RAID Controller SRCU42E has the following thermal, atmospheric, and safety characteristics.

- Temperature range: 0°C to 55°C (dry bulb)
- Relative humidity range: 5% to 90% noncondensing
- Maximum dew point temperature: 32°C
- Airflow must be sufficient to keep the heat sink temperature below 80°C

The following parameters define the storage and transit environment for the Intel[®] RAID Controller SRCU42E:

- Temperature range: -40°C to +105°C (dry bulb)
- Relative humidity range: 5% to 90% noncondensing

3.3.6 Safety Characteristics

The Intel® RAID Controller SRCU42E meets or exceeds the requirements of UL flammability rating 94 V0. Each bare board is also marked with the supplier's name or trademark, type, and UL flammability rating. Since these boards are installed in a PCI bus slot, all voltages are below the SELV 42.4 V limit.

Chapter A

Glossary of Terms and Abbreviations

Active Termination	The electrical connection required at each end of the SCSI bus, composed of active voltage regulation and a set of termination resistors. Ultra SCSI, Ultra2 SCSI, Ultra160 SCSI, and Ultra320 SCSI require active termination.
BIOS	Basic Input/Output System. Software that provides basic read/write capability. Usually kept as firmware (ROM based). The system BIOS on the mainboard of a computer is used to boot and control the system. The SCSI BIOS on your host controller acts as an extension of the system BIOS.
Configuration	Refers to the way a computer is setup; the combined hardware components (computer, monitor, keyboard, and peripheral devices) that make up a computer system; or the software settings that allow the hardware components to communicate with each other.
Device Driver	A program that allows a microprocessor (through the operating system) to direct the operation of a peripheral device.
Differential SCSI	A hardware configuration for connecting SCSI devices. It uses a pair of lines for each signal transfer (as opposed to Single-Ended SCSI which references each SCSI signal to a common ground).
Domain Validation	Domain Validation is a software procedure in which a host queries a device to determine its ability to communicate at the negotiated Ultra320 data rate.
EEPROM	Electronically Erasable Programmable Read Only Memory.
External SCSI Device	A SCSI device installed outside the computer cabinet. These devices are connected together using specific types of shielded cables.
Fusion-MPT Architecture	Fusion-MPT (Message Passing Technology) architecture consists of several main elements: Fusion-MPT firmware, the Fibre Channel and SCSI hardware, and the operating system level drivers that support these architectures. Fusion-MPT architecture offers a single binary, operating system driver that supports both Fibre Channel and SCSI devices now.
Host	The computer system in which the RAID controller is installed. It uses the RAID controller to transfer information to and from devices attached to the SCSI bus.
Host Adapter Board (HAB)	A circuit board or integrated circuit that provides a device connection to the computer system.
Internal SCSI Device	A SCSI device installed inside the computer cabinet. These devices are connected together using an unshielded ribbon cable.
Main Memory	The part of a computer's memory which is directly accessible by the CPU (usually synonymous with RAM).
NVRAM	NonVolatile Random Access Memory.

PCI Express*	Peripheral Component Interconnect. A high performance local bus specification that allows connection of devices directly to computer memory. The PCI Local Bus allows transparent upgrades from 32-bit data path at 33 MHz to 64-bit data path at 33 MHz, and from 32-bit data path at 66 MHz to 64-bit data path at 66 MHz.
Peripheral Devices	A piece of hardware (such as a video monitor, disk drive, printer, or CD-ROM) used with a computer and under the computer's control. SCSI peripherals are controlled through a SCSI RAID controller (host controller).
SCSI Bus	A RAID controller (host controller) and one or more SCSI peripherals connected by cables in a linear configuration. The controller may exist anywhere on the bus, allowing connection of both internal and external SCSI devices. A system may have more than one SCSI bus by using a multi-channel controller or by using multiple controllers.
SCSI Device	Any device that conforms to the SCSI standard and is attached to the SCSI bus by a SCSI cable. This includes SCSI RAID controllers (host controllers) and SCSI peripherals.
SCSI ID	A way to uniquely identify each SCSI device on the SCSI bus. Each SCSI bus has eight available SCSI IDs numbered 0 through 7 (or 0 through 15 for Wide SCSI). The RAID controller (host controller) usually gets the highest ID (7 or 15) giving it priority to control the bus.
Single-Ended SCSI	A hardware specification for connecting SCSI devices. It references each SCSI signal to a common ground. This is the most common method (as opposed to differential SCSI, which uses a separate ground for each signal).
TolerANT	A technology developed and used by Intel to improve data integrity, data transfer rates, and noise immunity through the use of active negation and input signal filtering.
Ultra SCSI	A standard for SCSI data transfers. It allows a transfer rate of up to 20 Mbytes/s over an 8-bit SCSI bus and up to 40 Mbytes/s over a 16-bit SCSI bus.
Ultra2 SCSI	A standard for SCSI data transfers. It allows a transfer rate of up to 40 Mbytes/s over an 8-bit SCSI bus, and up to 80 Mbytes/s over a 16-bit SCSI bus.
Ultra160 SCSI	A standard for SCSI data transfers. It allows a transfer rate of up to 160 Mbytes/s over a 16-bit SCSI bus.
Ultra320 SCSI	A standard for SCSI data transfers. It allows a transfer rate of up to 320 Mbytes/s over a 16-bit SCSI bus.
VHDCI	Very High-Density Cable Interconnect. This cable is used to connect external connectors to your RAID controller.