



# **Intel<sup>®</sup> Storage System SSR212MA**

***Technical Product Specification  
(Hardware)***

**Revision 1.4**

**Storage Group Technical Marketing**

---

## Revision History

Date	Revision Number	Modifications
May 12, 2005	0.1	Initial draft for review.
June 23, 2005	0.5	Updated graphics, updated MTBF table, added DOM graphic, corrected various branding errors.
August 11, 2005	0.6	Updated memory DIMM types, block diagram, DOM information, cooling module information, power supply specs.
September 13, 2005	0.99	Final review copy.
October 4, 2005	1.0	Release copy.
October 6, 2005	1.1	Corrected LED description in Table 4 (from Power Fault to Fault).
December 15, 2005	1.2	Removed Accessories & Spares list from Appendix.
April 27, 2006	1.3	Removed erroneous SAF-TE compliance claims, removed legal statement on page iii, "...design phase of development...", clarified Fan support from the Server Board in section 1.2, clarified that the backplane buzzer is disabled in section 1.4, clarified that the Intrusion Switch is not used with the SAN/IQ software in section 1.5.2.
June 22, 2006	1.4	Added RoHS statement, section 6.2.

## ***Disclaimers***

Information in this document is provided in connection with Intel® products. No license, express or implied, by estoppel or otherwise, to any intellectual property rights is granted by this document. Except as provided in Intel's Terms and Conditions of Sale for such products, Intel assumes no liability whatsoever, and Intel disclaims any express or implied warranty, relating to sale and/or use of Intel products including liability or warranties relating to fitness for a particular purpose, merchantability, or infringement of any patent, copyright or other intellectual property right. Intel products are not intended for use in medical, life saving, or life sustaining applications. Intel may make changes to specifications and product descriptions at any time, without notice.

Designers must not rely on the absence or characteristics of any features or instructions marked "reserved" or "undefined." Intel reserves these for future definition and shall have no responsibility whatsoever for conflicts or incompatibilities arising from future changes to them.

The Intel® Storage System SSR212MA may contain design defects or errors known as errata that may cause the product to deviate from published specifications. Current characterized errata are available on request.

Intel system boards contain a number of high-density VLSI and power delivery components that need adequate airflow to cool. Intel's own chassis are designed and tested to meet the intended thermal requirements of these components when the fully integrated system is used. It is the responsibility of the system integrator that chooses not to use Intel developed system building blocks to consult vendor datasheets and operating parameters to determine the amount of air flow required for their specific application and environmental conditions. Intel Corporation cannot be held responsible if components fail or the system board does not operate correctly when used outside any of their published operating or non-operating limits.

Intel, Pentium, Itanium, and Xeon are trademarks or registered trademarks of Intel Corporation.

\*Other brands and names may be claimed as the property of others.

Copyright © Intel Corporation 2003 - 2006.

# Table of Contents

<b>1. Feature Summary</b>	<b>1</b>
1.1 System Components	5
1.2 System Board Feature Set	7
1.3 Serial ATA (SATA) Host Bus Adapter	9
1.4 SATA Hot Swap Backplane	9
1.5 Enclosure Management	10
1.5.1 Fan Control	11
1.5.2 Miscellaneous Functions	11
1.5.3 I <sup>2</sup> C Serial Bus Interface	11
1.5.4 Hard Disk Drive LEDs	12
1.6 Chassis Dimensions and Weight	12
1.7 Back Panel I/O Ports and Features	13
1.8 Front Panel and HDD Bays	14
1.8.1 Front/Rear Panel Controls and Indicators	15
1.9 Fan Monitoring	15
1.10 Storage System Security	15
1.11 Rack and Cabinet Mounting Options	16
<b>2. Power Sub-System</b>	<b>17</b>
2.1 Power Supply Enclosure	17
2.1.1 Hot Swapping Power Modules	18
2.1.2 Power Supply Outputs	18
2.2 Output Power/Currents	19
2.3 Voltage Regulation	19
2.3.1 Dynamic Loading	20
2.4 Capacitive Loading	20
2.5 Protection Circuits	20
2.5.1 Over-Current Protection (OCP)	20
2.5.2 Over Voltage Protection (OVP)	22
2.5.3 Over Temperature Protection (OTP)	22
<b>3. System Cooling Module</b>	<b>23</b>
3.1 Fan Control	23
<b>4. Chassis Bays</b>	<b>24</b>

4.1	Hard Disk Drive Bays.....	25
4.1.1	Hard Disk Drive Carrier.....	26
4.2	Disk On Module (DOM) .....	28
4.2.1	Features.....	28
<b>5.</b>	<b>System Interconnection.....</b>	<b>29</b>
5.1	Chassis Internal Cables and Connector .....	29
5.2	I/O Panel Connectors .....	29
5.3	SATA HSBP Connectors .....	30
5.3.1	SATA 4-Lane Connector.....	30
5.3.2	Interposer Connector .....	31
5.3.3	Power Connector .....	31
5.3.4	Front Panel Connector.....	32
5.3.5	SATA Host I <sup>2</sup> C Header .....	32
<b>6.</b>	<b>Regulatory Information.....</b>	<b>33</b>
6.1	Product Regulation Requirements.....	33
6.1.1	Product Safety Compliance .....	33
6.1.2	Product EMC Compliance – Class A Compliance .....	33
6.1.3	Certifications / Registrations / Declarations .....	34
6.1.4	Component Regulation Requirement Need to Support System Level Certifications.....	34
6.1.5	Product Ecology Requirements .....	35
6.2	Restriction of Hazardous Substances (RoHS).....	35
<b>7.</b>	<b>Environmental Limits.....</b>	<b>36</b>
7.1	System Office Environment .....	36
7.2	System Environmental Testing .....	36
7.3	Environmental Limits .....	37
<b>8.</b>	<b>Serviceability and Availability.....</b>	<b>38</b>
<b>9.</b>	<b>Calculated MTBF .....</b>	<b>39</b>
<b>Appendix A: Spares and Accessories .....</b>		<b>I</b>
	Upgrade and Accessory Parts.....	I
<b>Glossary.....</b>		<b>II</b>

# List of Figures

Figure 1. Intel® Storage System SSR212MA .....	1
Figure 2. Intel® Storage System SSR212MA Block Diagram .....	5
Figure 3. System Components .....	6
Figure 4. SATA HSBP Block Diagram .....	10
Figure 5. SATA HSBP I <sup>2</sup> C Bus Connection Diagram .....	11
Figure 6. Chassis Rear .....	13
Figure 7. Chassis Front and Rear .....	14
Figure 8. Front Panel .....	15
Figure 9. Rack Mounting .....	16
Figure 10. Power Supply Enclosure .....	17
Figure 11. Cooling Module .....	23
Figure 12. Drive Bay Removal .....	24
Figure 13. Hard Disk Drive Bays .....	26
Figure 14. Hard Drive Carrier Assembly .....	27
Figure 15. Example Disk On Module .....	28

# List of Tables

<b>Table 1. HDD LED Function</b> .....	12
Table 2. Chassis Dimensions and Weight .....	12
Table 3. Rear Control Button Functions.....	15
Table 4. Front LED Indicator Status.....	15
Table 5. Enclosure & Module Output Summary (500W 10 second peak ratings).....	18
Table 6. LED Indicators .....	18
Table 7. Load Ratings.....	19
Table 8. Voltage Regulation Limits .....	19
Table 9. Transient Load Requirements.....	20
Table 10. Capacitive Loading Conditions .....	20
Table 11. Over Current Protection Limits.....	21
Table 12. Over Voltage Protection (OVP) Limits .....	22
Table 13. SATA 4-Lane Connector Pin-out .....	30
Table 14. Interposer Connector .....	31
Table 15. Power Connector Pin-out.....	31
Table 16. Front Panel Power Connector.....	32
Table 17. SATA Host I <sup>2</sup> C Header Pin-out .....	32
Table 18. Intel® Storage System SSR212MA System Office Environment Summary.....	36
Table 19. Intel® Storage System SSR212MA Operating and Non-Operating Environmental Limits .....	37
Table 20. Intel® Storage System SSR212MA Component MTBF Numbers .....	39

This page intentionally left blank



# 1. Feature Summary

---

This Technical Product Specification provides detailed information about the hardware components of the Intel® Storage System SSR212MA. Please refer to the *Intel® Storage System Software Manual* for complete feature, configuration and operation details of the Intel® Storage System SSR212MA Storage Area Network (SAN) Management Software that is shipped with each Storage System.

The Intel® Storage System SSR212MA includes a 2U chassis, Intel® Server Board SE7520JR2 with a single Intel® Xeon® processor, an Intel® Management Module (IMM), twelve Serial ATA hard disk drive carriers, two Intel® RAID Controller SRCS28X's, a single internal Disk On Module (DOM) boot device, dual Intel® PRO/1000 Network connections, and a single 500 W power supply (dual redundant 1+1 capable). Intel®-based system boards and chassis have feature sets designed to support the high-density storage market.

The Intel® Server Board SE7520JR2 that is installed in the Storage System SSR212MA chassis is a monolithic printed circuit board with features that were designed to support the storage system market. The architecture is based on the Intel® E7520 chipset and supports Intel® Xeon® processors.

For more information on the Intel® Storage System SSR212MA SAN Management Software, please refer to the *Intel® Storage System Software Manual* available from Intel Business Link (IBL), [support.intel.com](http://support.intel.com) or your Intel sales representative.



Figure 1. Intel® Storage System SSR212MA

**Intel® Storage System SSR212MA Hardware Feature Summary**

<b>Storage Capacity</b>	Expandable to 3.0 TB – using twelve 250 GB drives. Expandable to 4.8 TB – using twelve 400 GB drives. Expandable to 6.0 TB – using twelve 500 GB drives. Expandable to 7.2 TB – using twelve 600 GB drives (future).
<b>Drive Bays</b>	12 Serial ATA (SATA) Hot Pluggable.
<b>Hard Disk Drive Supported</b>	3.5 inch SATA.  <b>NOTE: For specific drive family and capacities supported, please refer to the SSR212MA Tested Hardware and OS List (THOL).</b>
<b>Processor</b>	A single Low Voltage Intel® Xeon® processor 2.80 GHz with 1 MB L2 cache.
<b>Memory Capacity</b>	Expandable to 16 GB maximum, using DDR2-400 memory.  <b>NOTE: Please see memory expansion recommendations in section 1.2 of this document.</b>
<b>Memory Type</b>	Synchronous Dynamic Random Access Memory (SDRAM), DDR2-400, Registered, ECC.
<b>DIMM Slots</b>	Six 184-pin DIMM sockets.
<b>Enclosure Controller</b>	On-board Vitesse* VSC055 micro-controller.
<b>Temperature Sensor</b>	Two temperature sensors are located on the backplane that allows drive cage temperature monitoring by enclosure management.
<b>SATA Compliance</b>	SATA 1.5, 3.0.
<b>Client Connectivity</b>	Client Connectivity via Internet Protocol Small Computer System Interface (iSCSI) Dual GB Ethernet.
<b>Serial Port</b>	Management console port.
<b>Front Panel</b>	
<b>LEDs</b>	Fault, ID, Power.
<b>Back Panel</b>	
<b>Buttons and Switches</b>	Power button, Reset button.
<b>I/O Connectors</b>	1x RJ-45 COMB Serial port, 2x RJ-45 Ethernet ports
<b>Power Receptacle</b>	1x IEC AC per installed power supply module.
<b>Chassis</b>	
<b>Form Factor</b>	2U rack-mount chassis
<b>Height</b>	86.7 mm, 3.41 in
<b>Width</b>	447 mm, 17.6 in
<b>Depth</b>	631 mm, 24.8 in
<b>Weight</b>	As shipped (zero drives): approximately 16 kg, 35.2 pounds Fully configured (twelve drives): approximately 27.5 kg, 61 pounds Shipping container: 3.2 kg, 7 pounds
<b>Color</b>	Black
<b>Rack Support</b>	Rail mount, compatible with four-post rack mount only, and compliant to the SSI Server Rack specification and EIA 310-D.
<b>System Cooling</b>	
<b>Fans</b>	Chassis includes three dual rotor and two single rotor 40 mm hot-swappable redundant system fans for cooling the hard drives,

	baseboard and SATA Host Bus Adapter (HBA) cards.  The Power supply enclosure contains one 60mm fan.
<b>Power</b>	
<b>Configuration</b>	500 W continuous, 1+1 redundant power supplies. Intel Storage System SSR212MA ships with one 500W power supply
<b>Max AC input current (PS Module)</b>	7.2 Amperes at 110 Vrms, 3.5 A at 220 Vrms (each power supply module)
<b>Max +3.3 V output (PS Enclosure)</b>	20.0 A (total combined power for the+ 3.3 V and +5 V outputs should not exceed 120 W).
<b>Max +5 V output (PS Enclosure)</b>	20.0 A (total combined power for the+ 3.3 V and +5 V outputs should not exceed 120 W).
<b>Max +12 V output1 current (PS Module)</b>	18.0 A (total combined power for the +12 V outputs should not exceed 360 W).
<b>Max +12 V output2 current (PS Module)</b>	18.0 A (total combined power for the +12 V outputs should not exceed 360 W).
<b>Max +12 V output3 current (PS Module)</b>	18.0 A (total combined power for the +12 V outputs should not exceed 360 W).
<b>Max -12 V output current (PS Module)</b>	0.5 A (each power supply module)
<b>Max +5V Standby output current (PS Module)</b>	2.0 A (each power supply module)
<b>Environment</b>	
<b>Ambient Temperature</b>	Operating (system): 10 degrees Celsius to +35 degrees Celsius, with maximum change not to exceed 10 degrees Celsius per hour; non-operating (system): -40 degrees Celsius to +70 degrees Celsius.
<b>Relative Humidity</b>	Non-operating: 90% @ 35 degrees Celsius non-condensing
<b>Acoustics</b>	< 7.0 BA (rack-mount) in an idle state in an normal office environment (23 degrees Celsius)
<b>Electrostatic Discharge</b>	15 KV per Intel test specification
<b>Safety Compliance</b>	
<b>Argentina</b>	IRAM
<b>Canada</b>	UL60950 – CSA (60950 (UL and cUL)
<b>China</b>	GB4943- CNCA Certification
<b>Europe, CE Mark</b>	EN60950 (complies with73/23/EEC)
<b>Germany</b>	GS License
<b>International</b>	IEC60950 (CB Report and Certificate)
<b>Nordic Countries</b>	EMKO-TSE (74-SEC) 207/94
<b>Russia</b>	GOST 50377-92

<b>United States</b>	UL– 60950 – CSA 60950 (UL and cUL)
<b>Electromagnetic Capability (Class A) (EMC)</b>	
<b>Australia/New Zealand</b>	AS/NZS 3548 (based on CISPR 22)
<b>Canada</b>	ICES-003
<b>China</b>	GB 9254 - CNCA Certification GB 17625 - (Harmonics) CNCA Certification
<b>Europe, CE Mark</b>	EN55022; EN55024 & EN61000-3-2;-3-3 (complies with 89/336/EEC)
<b>International</b>	CISPR 22
<b>Japan</b>	VCCI
<b>Korea</b>	RRL, MIC 1997-41 & 1997-42
<b>Russia</b>	GOST 29216-91 & 50628-95
<b>Taiwan</b>	CNS13438
<b>United States</b>	FCC, Part 15

## 1.1 System Components

A block diagram of the storage system functional components is shown below.

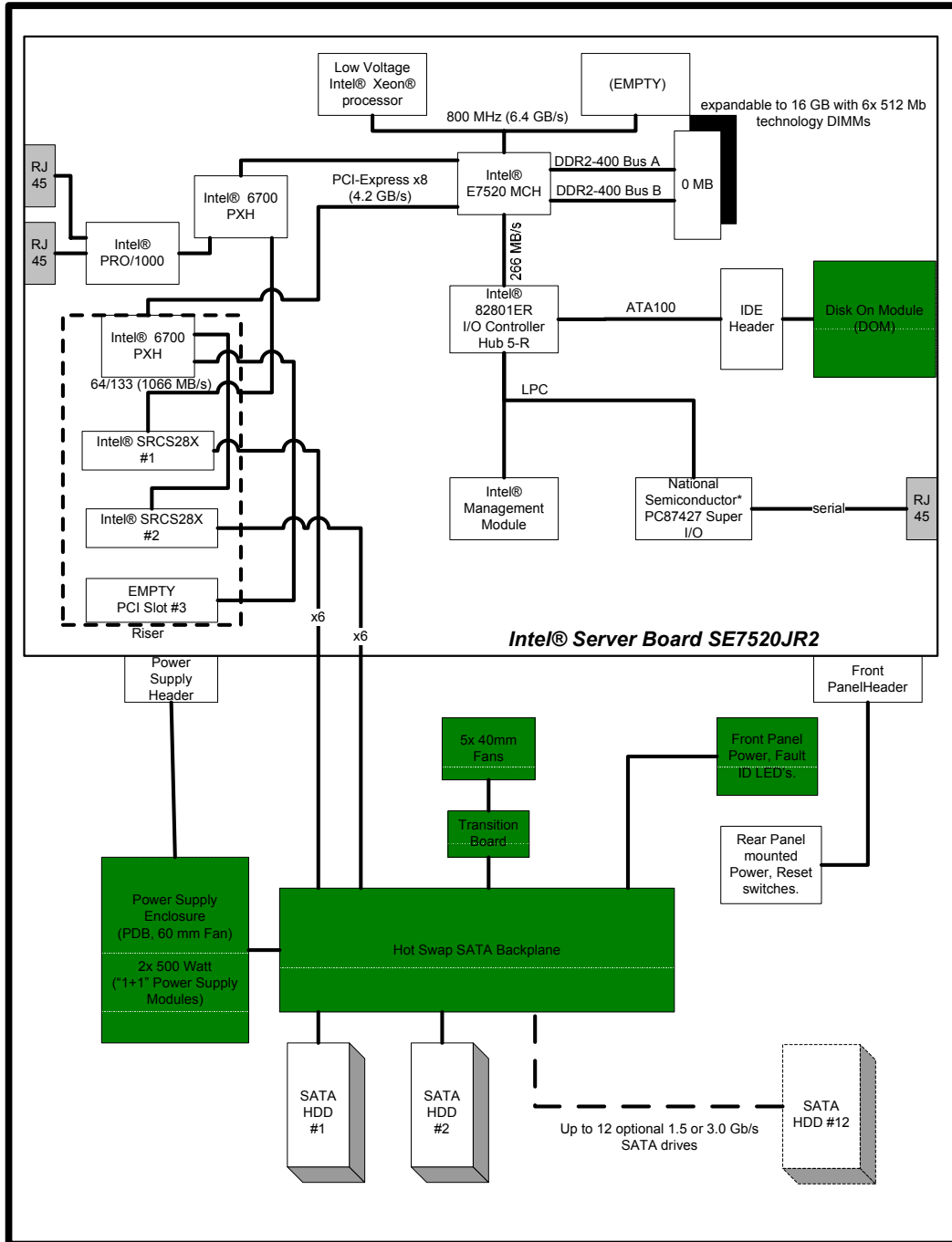

Figure 2. Intel® Storage System SSR212MA Block Diagram

The components included with this storage system are diagrammed below.

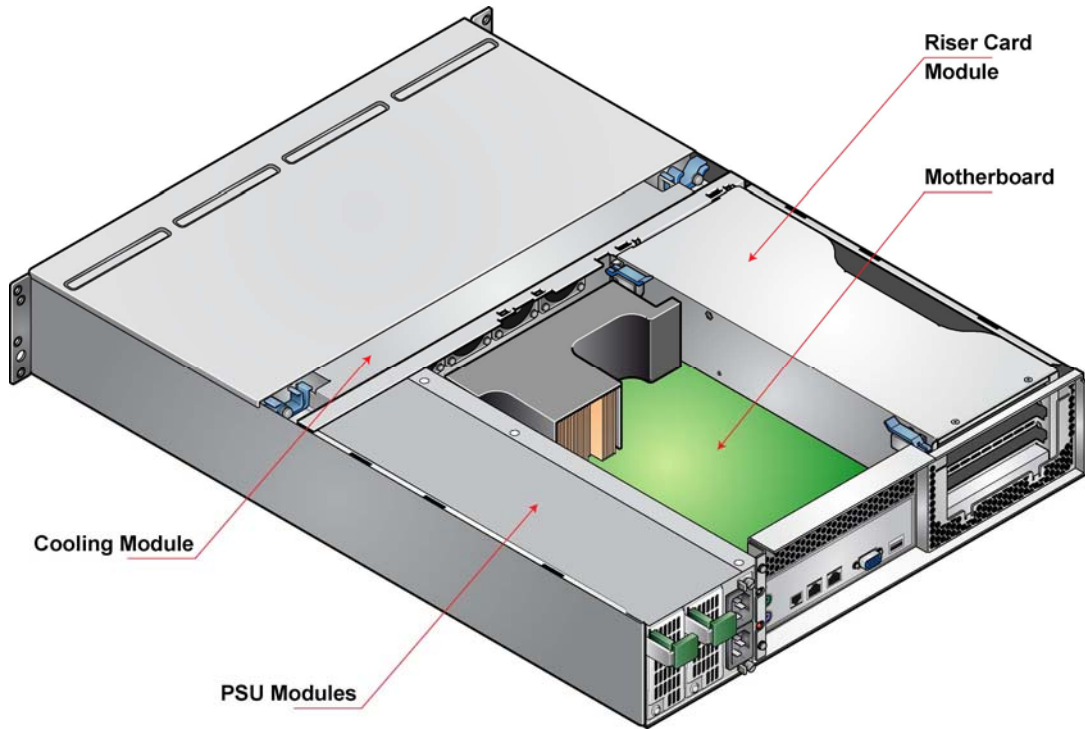

Figure 3. System Components

## 1.2 System Board Feature Set

The Intel® Server Board SE7520JR2 provides the following feature set, as implemented in the Storage System SSR212MA:

Feature	Description																																																																					
Processors	Dual 604-pin Socket Support for FC-mPGA2P Low Voltage Intel® Xeon® processors with 800 MHz system bus speed. <b>NOTE: Storage System only supports a single Low Voltage Intel® Xeon® processor 2.8 GHz with 800 MHz system bus and 1MB L2 cache.</b>																																																																					
Memory	<p>IMPORTANT: Intel® Storage System SSR212MA embedded operating system supports a maximum of 4 GB of system memory. See table below for recommended system memory based on drive quantities and drive capacity.</p> <ul style="list-style-type: none"> <li>▪ Six 184-pin DDR2-400 SDRAM Dual Inline Memory Module (DIMM) sockets</li> <li>▪ Support for up to 16 GB Registered Error Correcting Code (ECC) system memory , using DDR2-400 DIMMs.</li> <li>▪ Support for single-sided or double-sided DIMMs (DDR2-400)</li> </ul> <table border="1"> <thead> <tr> <th><b>SDRAM Parts/SDRAM Technology used</b></th> <th><b>128Mb</b></th> <th><b>256Mb</b></th> <th><b>512Mb</b></th> <th><b>1Gb</b></th> </tr> </thead> <tbody> <tr> <td>X8 single row</td> <td>128MB</td> <td>256MB</td> <td>512MB</td> <td>1GB</td> </tr> <tr> <td>X8 double row</td> <td>256MB</td> <td>512MB</td> <td>1GB</td> <td>2GB</td> </tr> <tr> <td>X4 single row</td> <td>256MB</td> <td>512MB</td> <td>1GB</td> <td>2GB</td> </tr> <tr> <td>X4 stacked double row</td> <td>512MB</td> <td>1GB</td> <td>2GB</td> <td>4GB</td> </tr> </tbody> </table> <p><b>Intel® Storage System SSR212MA memory upgrade guideline -</b></p> <p><b>Required minimum:</b> 200 MB + 200 MB per 1 TB of raw disk capacity + 128 MB per RAID 5 array.</p> <p><i>Example: for 12 x 500 GB drives and two RAID 5 arrays, memory requirements = 200 MB + (200 MB x 6.0) + 256 MB = 1.656 GB, therefore 2 GB.</i></p> <table border="1"> <thead> <tr> <th><b>Number of installed drives</b></th> <th><b>Drive Capacity</b></th> <th><b>RAID 5 Array</b></th> <th><b>Minimum Required Memory</b></th> </tr> </thead> <tbody> <tr> <td>6</td> <td>250 GB</td> <td>0</td> <td>500 MB</td> </tr> <tr> <td>6</td> <td>250 GB</td> <td>1</td> <td>628 MB</td> </tr> <tr> <td>6</td> <td>500 GB</td> <td>0</td> <td>800 MB</td> </tr> <tr> <td>6</td> <td>500 GB</td> <td>1</td> <td>928 MB</td> </tr> <tr> <td>12</td> <td>250 GB</td> <td>0</td> <td>800 MB</td> </tr> <tr> <td>12</td> <td>250 GB</td> <td>1</td> <td>928 MB</td> </tr> <tr> <td>12</td> <td>250 GB</td> <td>2</td> <td>1056 MB</td> </tr> <tr> <td>12</td> <td>500 GB</td> <td>0</td> <td>1400 MB</td> </tr> <tr> <td>12</td> <td>500 GB</td> <td>1</td> <td>1528 MB</td> </tr> <tr> <td>12</td> <td>500 GB</td> <td>2</td> <td>1656 MB</td> </tr> </tbody> </table>	<b>SDRAM Parts/SDRAM Technology used</b>	<b>128Mb</b>	<b>256Mb</b>	<b>512Mb</b>	<b>1Gb</b>	X8 single row	128MB	256MB	512MB	1GB	X8 double row	256MB	512MB	1GB	2GB	X4 single row	256MB	512MB	1GB	2GB	X4 stacked double row	512MB	1GB	2GB	4GB	<b>Number of installed drives</b>	<b>Drive Capacity</b>	<b>RAID 5 Array</b>	<b>Minimum Required Memory</b>	6	250 GB	0	500 MB	6	250 GB	1	628 MB	6	500 GB	0	800 MB	6	500 GB	1	928 MB	12	250 GB	0	800 MB	12	250 GB	1	928 MB	12	250 GB	2	1056 MB	12	500 GB	0	1400 MB	12	500 GB	1	1528 MB	12	500 GB	2	1656 MB
<b>SDRAM Parts/SDRAM Technology used</b>	<b>128Mb</b>	<b>256Mb</b>	<b>512Mb</b>	<b>1Gb</b>																																																																		
X8 single row	128MB	256MB	512MB	1GB																																																																		
X8 double row	256MB	512MB	1GB	2GB																																																																		
X4 single row	256MB	512MB	1GB	2GB																																																																		
X4 stacked double row	512MB	1GB	2GB	4GB																																																																		
<b>Number of installed drives</b>	<b>Drive Capacity</b>	<b>RAID 5 Array</b>	<b>Minimum Required Memory</b>																																																																			
6	250 GB	0	500 MB																																																																			
6	250 GB	1	628 MB																																																																			
6	500 GB	0	800 MB																																																																			
6	500 GB	1	928 MB																																																																			
12	250 GB	0	800 MB																																																																			
12	250 GB	1	928 MB																																																																			
12	250 GB	2	1056 MB																																																																			
12	500 GB	0	1400 MB																																																																			
12	500 GB	1	1528 MB																																																																			
12	500 GB	2	1656 MB																																																																			

Feature	Description
Chipset	Intel® E7520 chipset, consisting of: <ul style="list-style-type: none"> <li>▪ Intel® E7520 Memory Controller Hub (MCH)</li> <li>▪ Intel® 6700 PCI-X Controller Hub (PXH)</li> <li>▪ Intel® ICH5-R I/O Controller Hub (ICH)</li> <li>▪ Intel® 8 Mb (1 MB) Firmware Hub (FWH)</li> </ul>
Peripheral Interfaces	Four separate and independent PCI buses using Intel® Adaptive Slot Technology for high throughput of data via an active 2U riser board: <ul style="list-style-type: none"> <li>• Segment 1 (from baseboard): 64-bit, 133 MHz, 3.3 V, supporting the following configuration:               <ul style="list-style-type: none"> <li>○ One 64-bit/133 MHz PCI-X component                   <ul style="list-style-type: none"> <li>▪ Intel® 82546GB Dual 10/100/1000</li> </ul> </li> </ul> </li> <li>• Segment 2 (from baseboard): 64-bit, 133 MHz, 3.3 V, Full-length PCI supporting the following configuration:               <ul style="list-style-type: none"> <li>○ One riser slot 64-bit/133 MHz PCI-X                   <ul style="list-style-type: none"> <li>▪ Slot 1 SATA HBA #1.</li> </ul> </li> </ul> </li> <li>• Segment 3 (from riser): 64-bit, 133 MHz, 3.3 V, Full-length PCI supporting the following configuration:               <ul style="list-style-type: none"> <li>○ one slot: 64-bit/133 MHz PCI-X                   <ul style="list-style-type: none"> <li>▪ Slot 2 SATA HBA #2.</li> </ul> </li> </ul> </li> <li>• Segment 4 (from riser): 64-bit, 133 MHz, 3.3 V, Full-length PCI supporting the following configuration:               <ul style="list-style-type: none"> <li>○ one slot: 64-bit/133 MHz PCI-X                   <ul style="list-style-type: none"> <li>▪ Slot 3 used for FibreChannel or expanded Ethernet client connectivity.</li> </ul> </li> </ul> </li> <li>▪ One RJ-45 serial port for initial Intel Storage System SSR212MA configuration via a local console.</li> <li>▪ IDE interface for Disk On Module (DOM) support. .</li> </ul>
LAN	Intel® 82546GB Dual 10/100/1000 Megabits per second (Mb/s) Ethernet Local Area Network (LAN) Controller. Can be configured for failover or port aggregation.
Fans	Support for four system fans (not supported from the Intel® Server Board SE7520JR2 for SSR212MA).
BIOS	AMI* BIOS with support for: <ul style="list-style-type: none"> <li>▪ Advanced Configuration and Power Interface (ACPI)</li> <li>▪ 8 megabit symmetrical flash memory</li> <li>▪ Support for System Management Basic Input/Output System (SMBIOS)</li> </ul>
SSI interface support	Server System Infrastructure (SSI)-compliant connectors for SSI interface support: front panel, power connector.

Please refer to the Intel® Server Board SE7520JR2 Technical Product Specification available at <http://support.intel.com> for more information on the Storage System SSR212MA's server board.



### 1.3 Serial ATA (SATA) Host Bus Adapter

The Intel® Storage System SSR212MA ships with two 8 port PCI-X to SATA Host Bus Adapters. Each SATA HBA board provides the following feature set:

Feature	Description
Number of ports	8, using a single Marvell* 88SX6081 controller <b>NOTE: Only 6 of the 8 ports are utilized per HBA in SSR212MA.</b>
Serial ATA Bus Speed	1.5 and 3.0 Gb/s
Serial ATA Data Transfer rate	150 MB/s and 300 MB/s
PCI Bus width and speed	64-bit, 133 MHz
PCI Data transfer rate	1066 MB/s
RAID Levels	0, 1, 5, 10, 50
SDRAM Support	128 MB ECC DDR333 SDRAM
Cache function	Write-back, Write-through, Adaptive Read Ahead, Non-Read Ahead, Read Ahead, Cache I/O, Direct I/O
Hot Spare Pool	Yes
Hot Swap	Yes
Enclosure Management Support	Yes
Basic Input-Output (BIOS) RAID Management Tools	Yes, via BIOS RAID Management Tools
RAID Management Tools	Yes, via Intel® Storage Control Console (SCC)
Battery Back Up option	Yes, with 72 hour minimum hold up time

Please refer to the Intel® RAID Controller SRCS28X Hardware Users Guide available at <http://support.intel.com> for more information.

### 1.4 SATA Hot Swap Backplane

The SATA Hot Swap backplane board provides the following feature set:

Feature	Description
Supports up to 12 drives.	Slots provided for docking up to twelve 1.5 or 3.0 Gigabits per second (Gb/s) Serial ATA hot swap hard drives
Enclosure Management Controller	<ul style="list-style-type: none"> <li>• On-board Vitesse* VSC055 micro-controller with 256Kbit external SRAM memory</li> <li>• 2 SATA Host Controller I<sup>2</sup>C Interfaces</li> <li>• SATA and SATA-II extension compatibility</li> <li>• Hot swap support for up to 12 SATA Drives</li> </ul>
FRU/Configuration EEPROM	A Vitesse* VSC055* provides a serial EEPROM memory for storage of configuration and product FRU information.
Drive Status LEDs	Support for separate drive status LEDs that are visible at the front of each drive carrier. These LED's indicate the following: <ul style="list-style-type: none"> <li>• Green LED – <ul style="list-style-type: none"> <li>○ ON, Activity.</li> </ul> </li> <li>• Amber LED – <ul style="list-style-type: none"> <li>○ ON, drive fault.</li> </ul> </li> </ul>

Feature	Description
I <sup>2</sup> C Interface	Communication from the SATA HBA's to the server board is accomplished by two physical I <sup>2</sup> C Interfaces.
Audible Alarm	A piezo-electric buzzer on the backplane provides an audible alarm. However, this buzzer is disabled on the SSR212MA.

The following figure shows the functional blocks of the SATA Hot Swap Backplane.

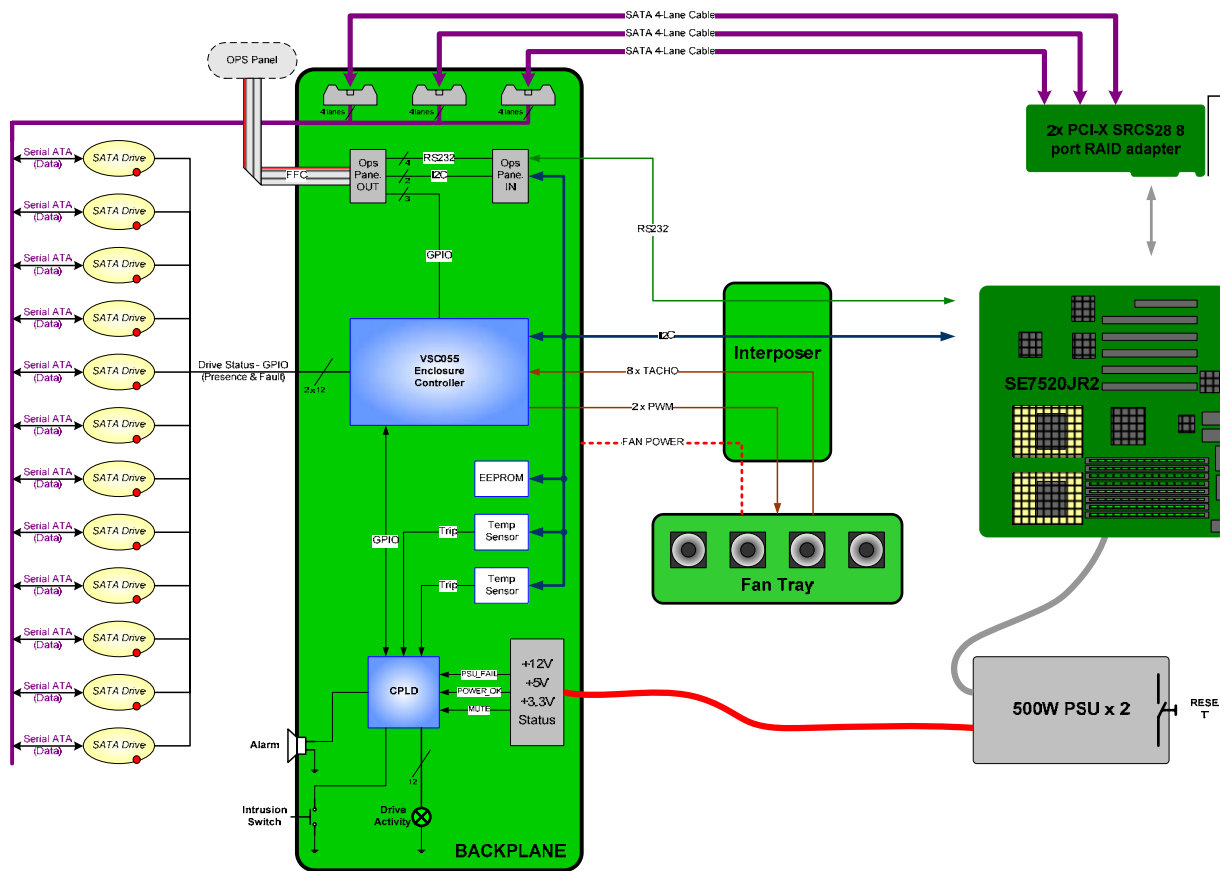

Figure 4. SATA HSBP Block Diagram

## 1.5 Enclosure Management

The enclosure management controller monitors various aspects of a storage enclosure.

The enclosure management controller is comprised of the following elements and supports associated features:



### 1.5.4 Hard Disk Drive LEDs

The Intel® Storage System SSR212MA SATA HSBP contains two LEDs for each of the twelve drive slots.

**Table 1. HDD LED Function**

Activity Light States	
Drive Status	LED
Idle	Both Off
Access in Progress	Green Blinking
Fault	Amber On

## 1.6 Chassis Dimensions and Weight

**Table 2. Chassis Dimensions and Weight**

Height	86.7 mm	3.41 inches
Width	447 mm	17.6 inches
Depth	631 mm	24.8 inches
Weight		
Chassis - as shipped (0 drives)	16 kilogram	35.2 pounds
Chassis - fully configured (12 drives)	27.5 kilogram	61 pounds
Shipping container	3.2 kilogram	7 pounds

## 1.7 Back Panel I/O Ports and Features

At the rear of the chassis is a serial management port and two 10/100/1000 Network Interface Card (NIC) connectors. The Input/Output (I/O) connectors are integrated to the back panel. The figure below shows the rear of the storage system.

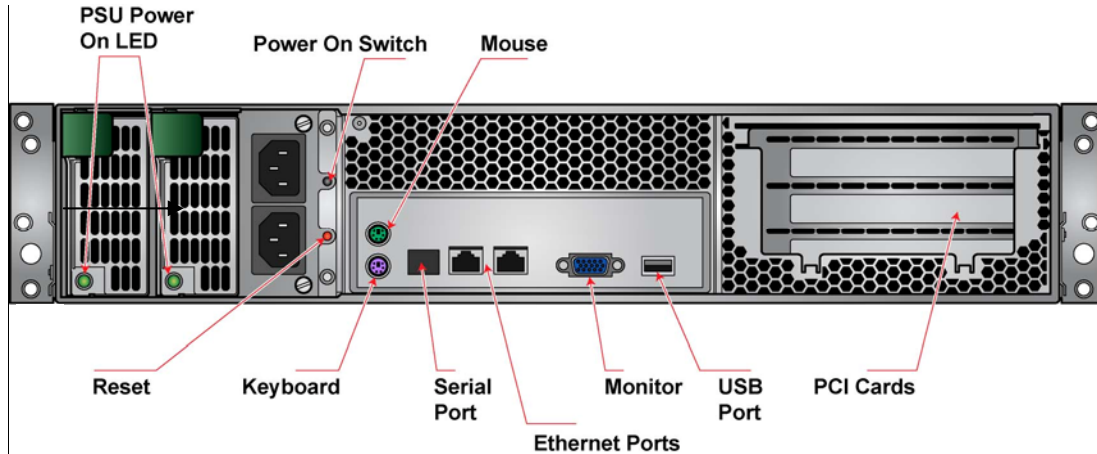

Figure 6. Chassis Rear

## 1.8 Front Panel and HDD Bays

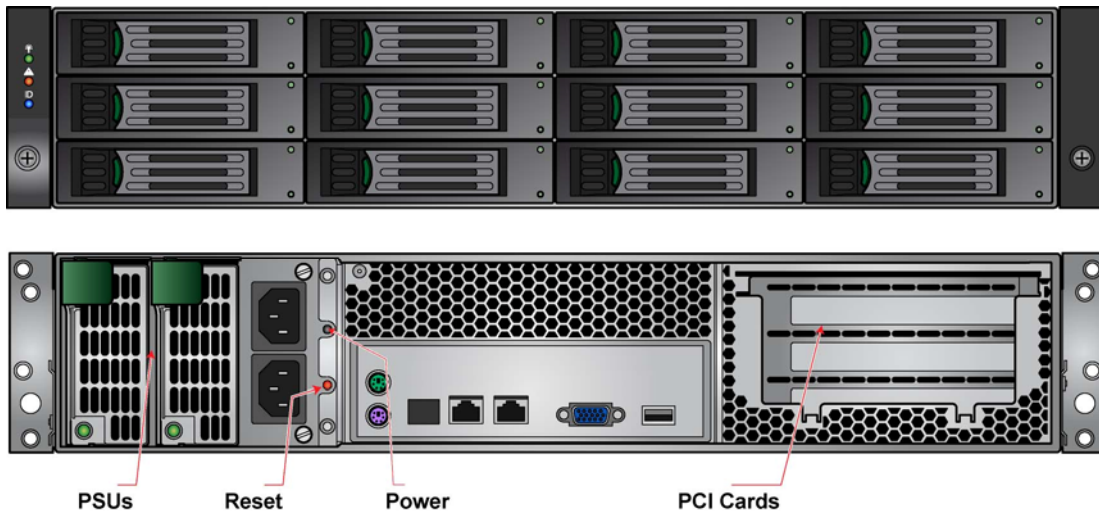

Figure 7. Chassis Front and Rear

### 1.8.1 Front/Rear Panel Controls and Indicators

The front/rear panel controls and indicators are defined below:

**Table 3. Rear Control Button Functions**

Power button	Toggles the system power on/off.
Reset button	Reboots the system.

**Table 4. Front LED Indicator Status**

Power On	Continuous green light indicates the system has power applied to it. No light indicates the system does not have power applied to it (other than 5 V standby power).
Fault	Continuous amber light indicates fault present.
Enclosure ID	The blue system identification LED is used to help identify a system for servicing. This is especially useful when the system is installed within a high density rack or cabinet that is populated with several similar systems.

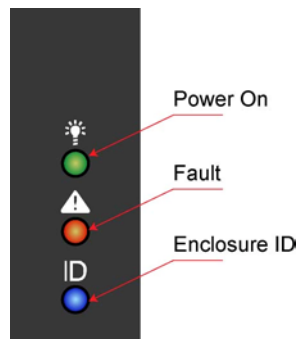

**Figure 8. Front Panel**

## 1.9 Fan Monitoring

The fans provided in the Storage System SSR212MA contain a tachometer signal that can be monitored by the SAN management software.

## 1.10 Storage System Security

The storage system includes a preinstalled intrusion switch that can be monitored by SAN management software. When the cover is opened, the switch, located on the left side of the chassis transmits a signal to the Intel Management Module (IMM) on the system board. Through SAN management software, the system can be programmed to respond to an intrusion by powering down or by sending an alert.

## 1.11 Rack and Cabinet Mounting Options

The chassis was designed to support cabinets that are 19 in (483 mm) wide by up to 36 in (914 mm) deep, and are compliant to the SSI Server Rack specification and EIA 310-D. A set of Rack Mounting Rails are provided and will accommodate either square or round hole rack mounting methods.

When mounting the system into a cabinet, the front mount brackets are attached to the front of the chassis, and a set of rear support brackets are attached to the back of the cabinet. This allows the weight of the system to be as evenly distributed as possible.

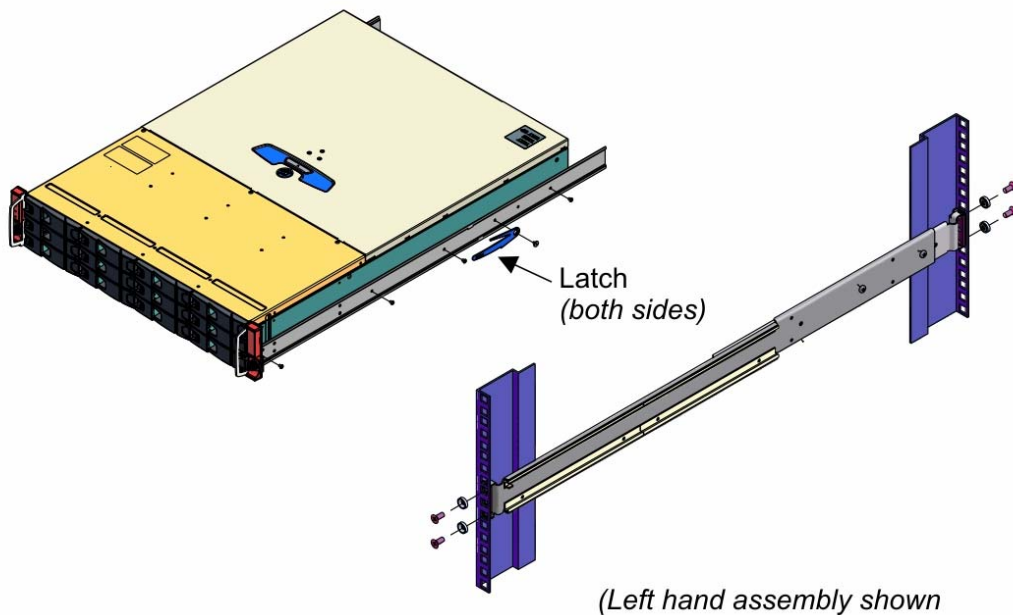

Figure 9. Rack Mounting



## 2. Power Sub-System

This section provides an overview of the Storage System SSR212MA power supply sub-system; the *power supply enclosure* and the *power supply module*. **NOTE: The Storage System SSR212MA ships with one 500 Watt power supply module.**

### 2.1 Power Supply Enclosure

The Storage System SSR212MA accommodates one or two 500 Watt (W) redundant power supply modules.

PARAMETER	MIN	RATED	MAX	Max Input Current
Voltage (low-line)	90 V <sub>rms</sub>	100-127 V <sub>rms</sub>	140 V <sub>rms</sub>	7.2 A <sub>rms</sub>
Voltage (high-line)	180 V <sub>rms</sub>	200-240 V <sub>rms</sub>	264 V <sub>rms</sub>	3.5 A <sub>rms</sub>
Frequency	47 Hz		63 Hz	

The system can operate with one failed module without loss of performance until the failed module is replaced. The modules can be replaced without powering down or disturbing system operation. The power supply is designed to minimize EMI.

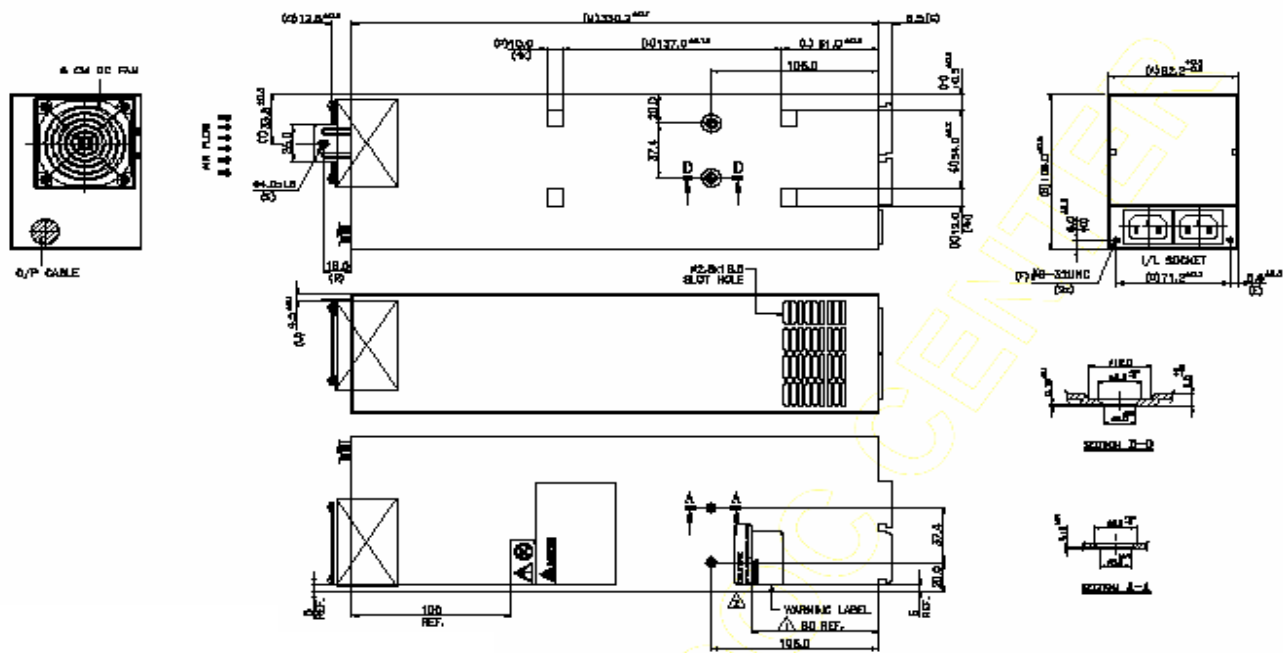

Figure 10. Power Supply Enclosure

### 2.1.1 Hot Swapping Power Modules

The Storage System SSR212MA power supply assembly is capable of supporting hot swapping of power supply modules in a 1+1 configuration.

### 2.1.2 Power Supply Outputs

The Storage System SSR212MA power system supports one or two 500 W Power Supply module's in a 1+1 redundant configuration. The power supply module provides five DC output rails; +12V1, +12V2, +12V3, -12V, +5VSB, while the Power Supply Enclosure provides two DC output rails: +3.3V and +5V.

**Table 5. Enclosure & Module Output Summary (500W 10 second peak ratings)**

+3.3V	+5V	+12V1	+12V2	+12V3	-12V	5VSB
20A	20A	18A	18A	18A	0.5A	2.5A

NOTE: The total combined power for +3.3V & +5V should not exceed 120W. The total combined power for +12V, -12V, 5VSB should not exceed 360W.

The module provides a handle to assist in insertion and extraction and can be inserted and extracted without the assistance of tools.

#### 2.1.2.1 Power Supply LED Indicator

The power supply module provides a single external bi-color LED to indicate the status of the power supply. When AC is applied to the Power Supply Unit (PSU) and standby voltages are available, the LED will blink green. The LED will be solid on green to indicate that all the power outputs are available. The LED will be solid on amber to indicate that the power supply has failed, shutdown due to over current, shutdown due to over temperature, or is indicating a predictive failure. Refer to the following table for conditions of the LED.

**Table 6. LED Indicators**

<b>POWER SUPPLY CONDITION</b>	<b>Power Supply LED</b>
No AC power to all PSU	OFF
No AC power to this PSU only	AMBER
AC present / Only Standby Outputs On	BLINK GREEN
Power supply Direct Current (DC) outputs ON and OK	GREEN
Power supply failure (includes over voltage, over temperature)	AMBER
Voltage Regulator Module (VRM) failure (cage related)	BLINK GREEN
240VA limit (cage related)	BLINK GREEN
Current limit	AMBER

## 2.2 Output Power/Currents

The following table defines power and current ratings for this 500 Watt continuous (606 Watts peak) power supply in 1+0 or 1+1 redundant configuration. The combined output power of both outputs shall not exceed the rated output power. The power supply must meet both static and dynamic voltage regulation requirements for the minimum loading conditions. Also, the power supply shall be able to supply the listed peak currents and power for a minimum of 10 seconds. Outputs are not required to be peak loaded simultaneously.

**Table 7. Load Ratings**

	<b>+3.3V</b>	<b>+5V</b>	<b>+12V1</b>	<b>+12V2</b>	<b>+12V3</b>	<b>-12V</b>	<b>5VSB</b>
MAX	20A	20A	18A	18A	18A	0.5A	2.0A
MIN STATIC	0.5A	0.5A	1.5A	1.5A	0.5A	0A	0A
MIN DYNAMIC	2A	2A	1.5A	1.5A	1.5A	0A	0A

NOTE: The total combined power for +3.3V & +5V should not exceed 120W. The total combined power for +12V, -12V, 5VSB should not exceed 360W.

## 2.3 Voltage Regulation

The power supply output voltages must stay within the following voltage limits when operating at steady state and dynamic loading conditions. All outputs are measured with reference to the return remote sense signal (ReturnS).

**Table 8. Voltage Regulation Limits**

<b>PARAMETER</b>	<b>MIN</b>	<b>NOM</b>	<b>MAX</b>	<b>UNITS</b>	<b>TOLERANCE</b>
+3.3V	+3.25	+3.30	+3.35	V <sub>rms</sub>	+1.5/-1.5%
+5V	+4.90	+5.00	+5.10	V <sub>rms</sub>	+2/-2%
+12V1	+11.76	+12.00	+12.24	V <sub>rms</sub>	+2/-2%
+12V2	+11.76	+12.00	+12.24	V <sub>rms</sub>	+2/-2%
+12V3	+11.76	+12.00	+12.24	V <sub>rms</sub>	+2/-2%
-12V	-11.40	-12.20	-13.08	V <sub>rms</sub>	+9/-5%
+5VSB	+4.85	+5.00	+5.20	V <sub>rms</sub>	+4/-3%

### 2.3.1 Dynamic Loading

The output voltages shall remain within limits specified in Table 9 for the step loading and capacitive loading specified in Table 10, below. The load transient repetition rate shall be tested between 50 Hz and 5 KHz at duty cycles ranging from 10%-90%. The load transient repetition rate is only a test specification. The  $\Delta$  step load may occur anywhere within the MIN load to the MAX load shown in Table 10.

**Table 9. Transient Load Requirements**

Output	$\Delta$ Step Load Size	Load Slew Rate	Capacitive Load
+3.3V	6A	0.5 A/ $\mu$ sec	5,600 $\mu$ F
+5V	6A	0.5 A/ $\mu$ sec	1,000 $\mu$ F
+12V1	13A	0.5 A/ $\mu$ sec	1,000 $\mu$ F
+12V2	5A	0.5 A/ $\mu$ sec	1,000 $\mu$ F
+12V3	5A	0.5 A/ $\mu$ sec	1,000 $\mu$ F
+5VSB	1A	0.5 A/ $\mu$ sec	0 $\mu$ F

## 2.4 Capacitive Loading

The power supply shall be stable and meet all requirements with the following capacitive loading ranges. Min capacitive loading applies to static load only.

**Table 10. Capacitive Loading Conditions**

Output	Minimum Turn-on Capacitance	Maximum Dynamic Capacitance	Units
+3.3V	10	68,000	$\mu$ F
+5V	10	24,000	$\mu$ F
+12V1	10	11,000	$\mu$ F
+12V2	10	11,000	$\mu$ F
+12V3	10	11,000	$\mu$ F
-12V	1	350	$\mu$ F
+5VSB	1	350	$\mu$ F

## 2.5 Protection Circuits

Protection circuits inside the power supply shall cause only the power supply's main outputs to shutdown. If the power supply latches off due to a protection circuit tripping, an AC cycle OFF for 15 sec and a PSON<sup>#</sup> cycle HIGH for 1sec shall be able to reset the power supply.

### 2.5.1 Over-Current Protection (OCP)

The power supply shall have current limit to prevent the +12 V and 5Vsb outputs from exceeding the values shown below. If the current limits are exceeded the power supply shall shutdown and latch off. The latch will be cleared by toggling the PSON<sup>#</sup> signal or by an AC power interruption. The power supply shall not be damaged from repeated power cycling in this

condition. 5Vsb shall be protected under over-current or shorted conditions, so that no damage can occur to the power supply.

**Table 11. Over Current Protection Limits**

<b>VOLTAGE</b>	<b>OVER CURRENT LIMIT (I<sub>out</sub> limit)</b>
+3.3V	<30A
+5V	<30A
+12V1	18.2A
+12V2	18.2A
+12V3	18.2A
-12V	Short Circuit
5VSB	Short Circuit

### 2.5.2 Over Voltage Protection (OVP)

The power supply over voltage protection shall be locally sensed. The power supply shall shutdown and latch off after an over voltage condition occurs. This latch shall be cleared by toggling the PSON<sup>#</sup> signal or by an AC power interruption. Table 13 contains the over voltage limits. The values are measured at the output of the power supply's connectors. The voltage shall never exceed the maximum levels when measured at the power pins of the power supply connector during any single point of fail. The voltage shall never trip any lower than the minimum levels when measured at the power pins of the power supply connector.

**Table 12. Over Voltage Protection (OVP) Limits**

<b>Output Voltage</b>	<b>MIN (V)</b>	<b>MAX (V)</b>
+3.3V	3.8	4.3
+5V	5.7	6.5
+12V1	13.5	15.0
+12V2	13.5	15.0
+12V3	13.5	15.0
-12V	-13.3	-14.5
+5VSB	5.7	6.5

### 2.5.3 Over Temperature Protection (OTP)

The power supply will be protected against over temperature conditions caused by loss of fan cooling or excessive ambient temperature. In an OTP condition the PSU will shutdown. When the power supply temperature drops to within specified limits, the power supply shall restore power automatically. The OTP circuit must have built in hysteresis such that the power supply will not oscillate on and off due to temperature recovering condition. The power supply shall alert the system of the OTP condition via the power supply FAIL signal and the amber LED.

## 3. System Cooling Module

---

The Storage System SSR212MA includes a cooling module that has three dual rotor 40 mm fans and two single rotor 40 mm fans, mounted in a common frame for ease of maintenance. The fans are mounted in a single fan tray located in the center of the chassis. The Power Supply enclosure contains one 60 mm fan for cooling the power supply modules.

### 3.1 Fan Control

Each fan within the module is capable of supporting multiple speeds. At normal room ambient of 23 degrees Celsius (C), the fans will run at slow speed for best acoustic performance. If the external temperature of the system increases, the backplane fan control circuitry will increase fan speed to compensate for the increased ambient.

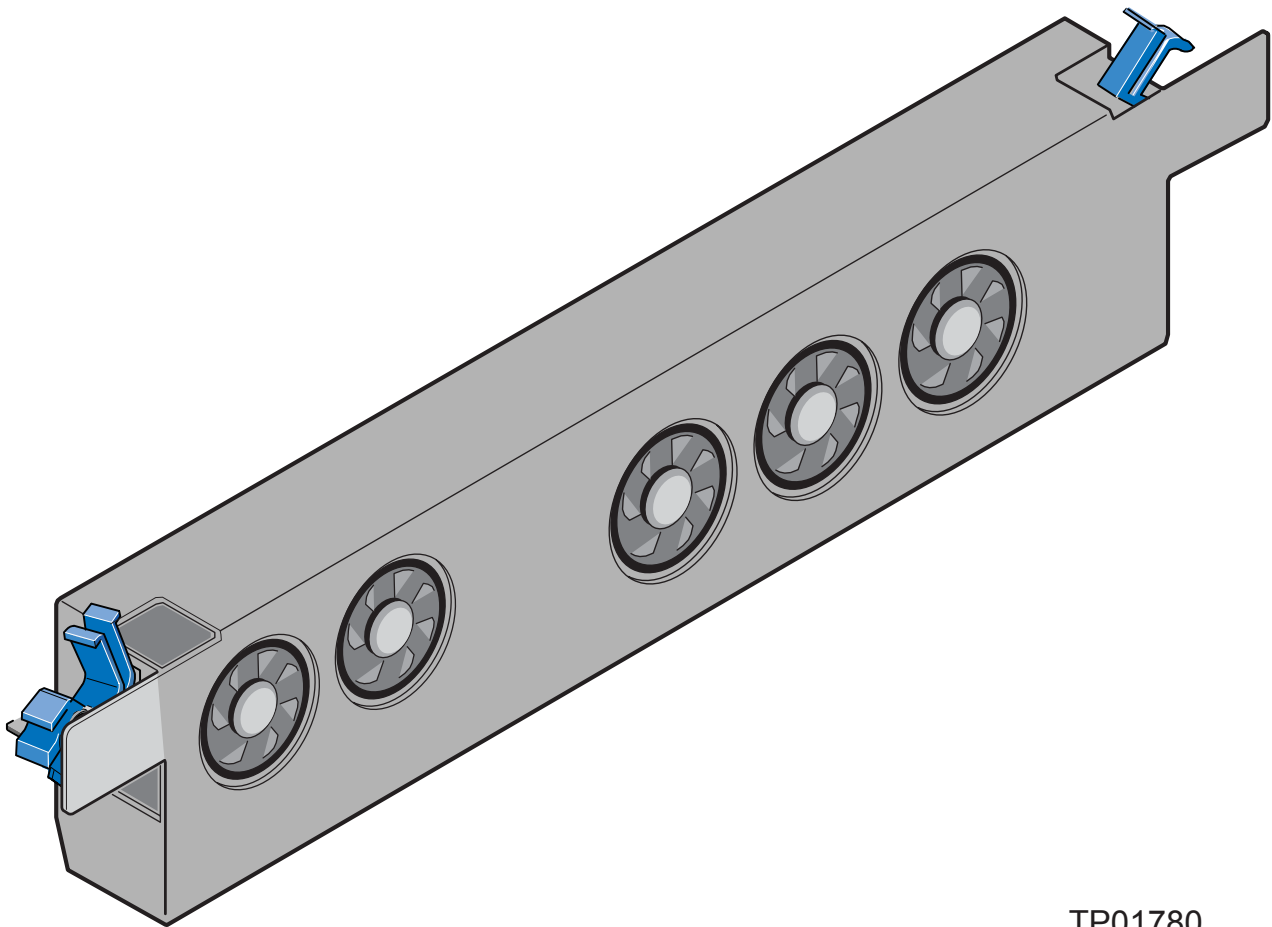

TP01780

Figure 11. Cooling Module

## 4. Chassis Bays

---

The Storage System SSR212MA chassis provides twelve hard drive bays at the front of the chassis. All hard drive bays may be populated with a carrier-mounted 3.5 inch SATA hard disk drive.

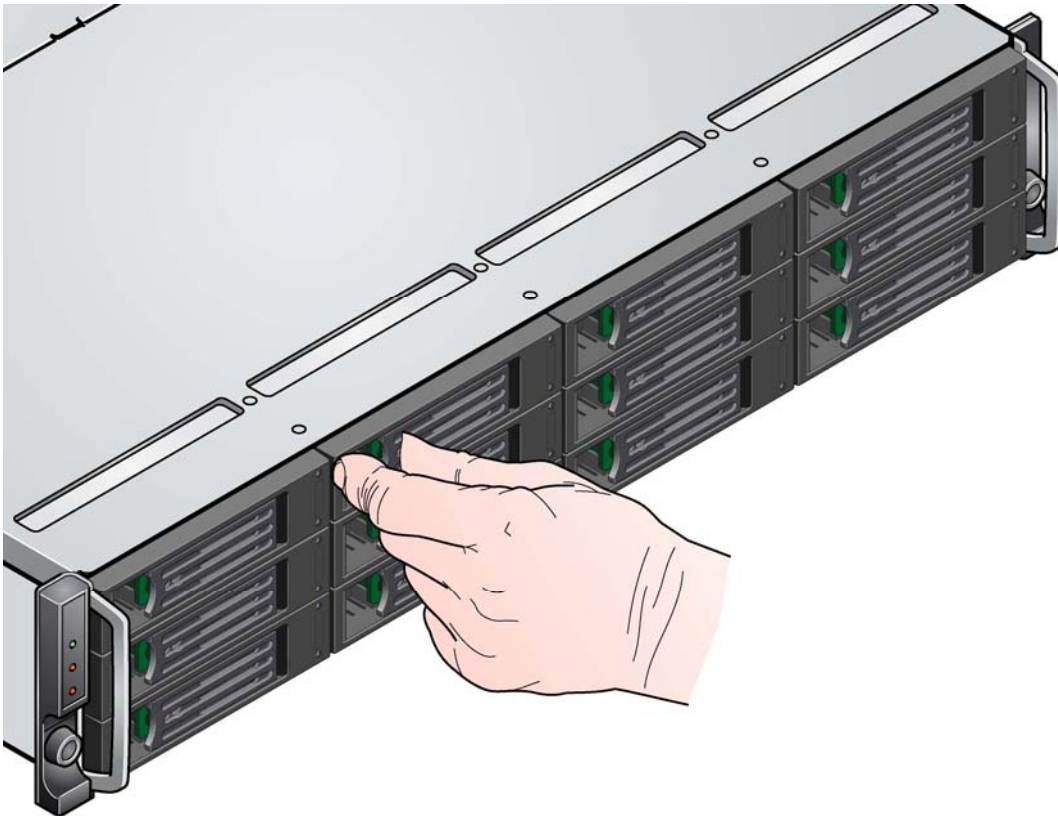

Figure 12. Drive Bay Removal



## 4.1 Hard Disk Drive Bays

The Storage System SSR212MA chassis can support up to twelve carrier-mounted SATA, 3.5 inch x 1 inch, hard disk drives. The SATA drives may be “electrically” hot-swapped while the system power is applied, i.e., before or during POST. However, the SATA drives should NOT be hot-swapped while the SAN Management application software is configured and active. See the Intel® Storage System Software Manual for more information.

### NOTE:

- 1) Drive bays 1 thru 6 are controlled by a single Intel® RAID Controller SRCS28X, while drive bays 7 thru 12 are controlled by a second Intel® RAID Controller SRCS28X.
- 2) All drives must be populated in order, from left to right, top to bottom, in drive bay 1 thru drive bay 12, but sequentially distributed across both SRCS28X SATA HBA's. For example, if only 8 drives are installed, 6 drives should be inserted into bays 1 thru 6, and two drives inserted into bays 7 and 8.

<b>1</b>	<b>2</b>	<b>3</b>	<b>4</b>
<b>5</b>	<b>6</b>	<b>7</b>	<b>8</b>
<b>9</b>	<b>10</b>	<b>11</b>	<b>12</b>

- 3) Once a particular RAID configuration is applied to the present drives, if the drives are removed from the system for any reason, they will need to be re-installed in the exact same drive bays they were removed from. Please use the HDD labels provided in your Storage System SSR212MA shipping container to number the drives 1 thru 12 prior to removal.
- 4) If a failed drive needs replacing, it must be replaced with the exact same manufacturer, model, and size.
- 5) For more information on configuring supported RAID levels, refer to the Intel® Storage System SSR212MA Software User Manual available from Intel Business Link (IBL), [support.intel.com](http://support.intel.com), or your Intel sales representative.

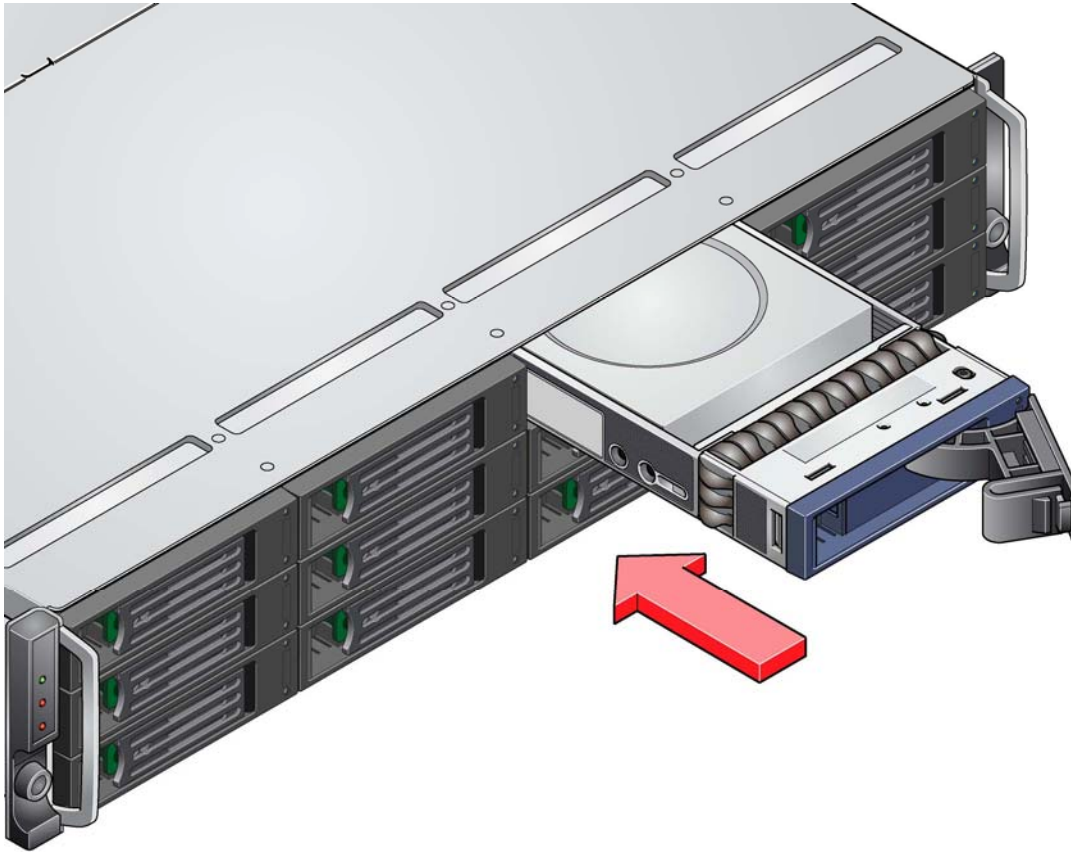

Figure 13. Hard Disk Drive Bays

#### 4.1.1 Hard Disk Drive Carrier

Each hard drive used in the system must be mounted to a drive carrier, making insertion and extraction of the drive from the chassis very simple. Each drive tray has its own dual purpose latching mechanism that is used to both insert/extract drives from the chassis and lock the carrier in place, and also has a safety locking mechanism to aid in the prevention of accidental removal of a drive. After the drive is inserted and latched, the locking feature is enabled by rotating the locking mechanism using the provided Torx\* or “star” bit tool, such that the latch can not be depressed to remove the drive. To remove the drive, turn the locking mechanism until the latch can be depressed to remove the drive. Each drive carrier also supports a light pipe providing a drive status indicator, located on the backplane, to be viewable from the front of the chassis.



Figure 14. Hard Drive Carrier Assembly

## 4.2 Disk On Module (DOM)

The Storage System SSR212MA ships with a single 512 MB Disk On Module (DOM) installed directly to the SSR212MA baseboard's IDE connector. The DOM is a storage device based on flash memory technology, which emulates an ordinary magnetic hard disk drive.

The DOM is segmented into two 256 MB useable redundant areas. The OS and SAN Application Software resides on one 256 MB block, while the other 256 MB area is reserved for upgrades. In the event of a catastrophic failure while performing an OS/SAN Application Software upgrade, the system will automatically boot from the previously known good image.



Figure 15. Example Disk On Module

NOTE:

- 1) The DOM contains the Storage System SSR212MA OS and SAN Application software, and should never be removed from the IDE connector while the system is operational, or data corruption could occur.
- 2) For more information on how to upgrade the Storage System SSR212MA SAN Management Software, please refer to the *Intel® Storage System Software Manual* available from Intel Business Link (IBL) or your Intel sales representative.

**WARNING – Like any IDE device, the DOM should not be removed from the IDE connector with power applied or damage to the DOM could occur.**

### 4.2.1 Features

- Standard 40 pin IDE connector interface.
- Non-volatile NAND type flash memory.
- 100% True IDE mode.
- +3.3 and +5 V operation.
- 1,000,000 hour MTBF.

## 5. System Interconnection

---

### 5.1 Chassis Internal Cables and Connector

The following cables and connectors are provided:

- Three SFF-8484 vertical four lane Serial ATA (SATA) cables ship with the Storage System SSR212MA. These cables support the twelve expansion drives and provide interconnect between the backplane and the two SATA HBA's.

### 5.2 I/O Panel Connectors

The Storage System SSR212MA provides an aperture for the rear I/O ports. The following are the I/O ports available:

- Two RJ-45 LAN connectors
- One RJ-45 Serial B Port
  
- One Stacked PS2 port for keyboard & mouse\*
- One DB15 graphics connector\*
- Two USB 2.0 ports\*

**NOTE:** \* denotes these connectors are not typically used in a SAN System environment, and should not be used to configure the Storage System SSR212MA.

## 5.3 SATA HSBP Connectors

### 5.3.1 SATA 4-Lane Connector

The following table defines the pin-outs of the three SATA 4-Lane Drive Connectors. The first connector carries signals from drive 1 to 4, the second connector is connected to drives 5 to 8 and the third connector connects to drives 9 to 12.

**Table 13. SATA 4-Lane Connector Pin-out**

Pin	Signal Name	Pin	Signal Name
1	GND	17	HBA_ACT7
2	DRIVE4_PORT3	18	NC.
3	DRIVE4_PORT2	19	NC.
4	GND	20	GND
5	DRIVE4_PORT1	21	DRIVE6_PORT3
6	DRIVE4_PORT0	22	DRIVE6_PORT2
7	GND	23	GND
8	DRIVE5_PORT3	24	DRIVE6_PORT1
9	DRIVE5_PORT2	25	DRIVE6_PORT0
10	GND	26	GND
11	DRIVE5_PORT1	27	DRIVE7_PORT3
12	DRIVE5_PORT0	28	DRIVE7_PORT2
13	GND	29	GND
14	HBA_ACT4	30	DRIVE7_PORT1
15	HBA_ACT5	31	DRIVE7_PORT0
16	HBA_ACT6	32	GND
16	HBA_ACT2	32	GND

### 5.3.2 Interposer Connector

The following table defines the pin-outs of the Interposer Connector.

**Table 14. Interposer Connector**

Pin	Signal Name	Pin	Signal Name
1	POWER_SWITCH	2	GND
3	GND	4	GND
5	FAN_PWR_BANK2	6	GND
7	FAN_PWR_BANK2	8	GND
9	FAN_PWR_BANK2	10	GND
11	I2C_SCL_A	12	FAN_TACHO0
13	I2C_SDA_A	14	FAN_TACHO1
15	I2C_SCL_B	16	FAN_TACHO2
17	I2C_SDA_B	18	FAN_TACHO3
19	COM_TX	20	FAN_TACHO4
21	COM_CTS	22	FAN_TACHO5
23	COM_RX	24	FAN_TACHO6
25	COM_RTS	26	FAN_TACHO7
27	FAN_PWR_BANK1	28	GND
29	FAN_PWR_BANK1	30	GND
31	FAN_PWR_BANK1	32	GND
33	GND	34	GND
35	GND	36	GND

### 5.3.3 Power Connector

The following table defines the pin-outs of the 2x12 Power Connectors.

**Table 15. Power Connector Pin-out**

Pin	Signal Name	Pin	Signal Name
1	+12V	13	GND
2	+12V	14	GND
3	+12V	15	GND
4	+12V	16	GND
5	+12V	17	GND
6	+5V	18	GND
7	+5V	19	GND
8	+5V	20	GND
9	+3.3V	21	GND
10	+3.3V	22	GND
11	MUTE_L	23	PSU_FAIL_L
12	POWER_SWITCH	24	PSU_POK

### 5.3.4 Front Panel Connector

The following table defines the pin-outs of the 1x14 Front Panel connector.

**Table 16. Front Panel Power Connector**

Pin	Signal Name
1	GND
2	COM_CTS
3	COM_RX
4	COM_TX
5	COM_RTS
6	GND
7	+5V_OPS
8	+5V_OPS
9	I2C_SDA_OPS
10	I2C_SCL_OPS
11	LED1_OPS/SPARE1 (power)
12	LED2_OPS/SPARE2 (fault)
13	LED3_OPS/SPARE3 (ID)
14	GND

### 5.3.5 SATA Host I<sup>2</sup>C Header

The following table defines the pin-outs of the two 3-pin SATA Host I<sup>2</sup>C Headers.

**Table 17. SATA Host I<sup>2</sup>C Header Pin-out**

Pin	Signal Name
1	I2C_SCL_A
2	GND
3	I2C_SDA_A
Pin	Signal Name
1	I2C_SCL_B
2	GND
3	I2C_SDA_B



## 6. Regulatory Information

---

### 6.1 Product Regulation Requirements

**Intended Application** – This product was evaluated as Information Technology Equipment (ITE), which may be installed in offices, schools, computer rooms, and similar commercial type locations. The suitability of this product for other product categories and environments (such as: medical, industrial, telecommunications, NEBS, residential, alarm systems, test equipment, etc.), other than an ITE application, may require further evaluation.

#### 6.1.1 Product Safety Compliance

UL60950 – CSA 60950(USA / Canada)  
EN60950 (Europe)  
IEC60950 (International)  
CB Certificate & Report, IEC60950 (report to include all country national deviations)  
GS License (Germany)  
GOST R 50377-92 - License (Russia)  
Belarus License (Belarus)  
Ukraine License (Ukraine)  
CE - Low Voltage Directive 73/23/EEE (Europe)  
IRAM Certification (Argentina)  
GB4943- CNCA Certification (China)

#### 6.1.2 Product EMC Compliance – Class A Compliance

**Note:** Legally the product is required to comply with Class A emission requirements as it is intended for a commercial type market place. Intel targets 10db margin to Class A Limits

FCC /ICES-003 - Emissions (USA/Canada) Verification  
CISPR 22 – Emissions (International)  
EN55022 - Emissions (Europe)  
EN55024 - Immunity (Europe)  
EN61000-3-2 - Harmonics (Europe)  
EN61000-3-3 - Voltage Flicker (Europe)  
CE – EMC Directive 89/336/EEC (Europe)  
VCCI Emissions (Japan)  
AS/NZS 3548 Emissions (Australia / New Zealand)  
BSMI CNS13438 Emissions (Taiwan)  
GOST R 29216-91 Emissions (Russia)  
GOST R 50628-95 Immunity (Russia)  
Belarus License (Belarus)  
Ukraine License (Ukraine)  
RRL MIC Notice No. 1997-41 (EMC) & 1997-42 (EMI) (Korea)  
GB 9254 - CNCA Certification (China)  
GB 17625 - (Harmonics) CNCA Certification (China)

### 6.1.3 Certifications / Registrations / Declarations

UL Certification (US/Canada)  
CE Declaration of Conformity (CENELEC Europe)  
FCC/ICES-003 Class A Attestation (USA/Canada)  
VCCI Certification (Japan)  
C-Tick Declaration of Conformity (Australia)  
MED Declaration of Conformity (New Zealand)  
BSMI Certification (Taiwan)  
GOST R Certification / License (Russia)  
Belarus Certification / License (Belarus)  
RRL Certification (Korea)  
IRAM Certification (Argentina)  
Ecology Declaration (International)  
GB4943- CNCA Certification (China)

### 6.1.4 Component Regulation Requirement Need to Support System Level Certifications

Component Power Supplies must have the following certifications:

- UL, cUL
- German Bauart
- CNCA China Certification
- Ctick DOC
- BSMI DOC
- RRL License
- CE DOC

CB Report (including all national deviations).

All peripheral devices, such as CD ROMS, Disk drives, Tape drives shall have the following certifications: UL or CSA NRTL, CSA or cUL, and TUV or VDE and SEMKO or NEMKO or DEMKO or FIMKO, CE, and FCC.

All Fans shall have the minimum certifications: UL and TUV or VDE

All current limiting devices shall have UL and TUV or VDE certifications and shall be suitable rated for the application where the device in its application complies with IEC60950.

All lithium batteries shall be UL recognized and battery circuits are to have suitable reverse bias current protection for the application it is used in.

All printed wiring boards shall be rated UL94V-0 and be sourced from a UL approved printed wiring board manufacturer.

All connectors shall be UL recognized and have a UL flame rating of UL94V-0.

All wiring harnesses shall be sourced from a UL approved wiring harness manufacturer. SELV Cable to be rated minimum 80 V.

All plastics used must be made of a UL recognized material, and have the appropriate flame ratings mandated by IEC60950 per system level requirements. All plastics parts shall be manufactured by an UL approved fabricator and the parts shall be marked with the appropriate UL traceability markings. Markings to include:

Plastic Fabricators name and/or UL Fabricator ID

Material Name (for example GE, C2800)

Date Code

Product safety label must be printed on UL approved label stock and printer ribbon. Alternatively labels can be purchased from a UL approved label manufacturer.

The product must be marked with the correct regulatory markings to support the certifications that are specified.

Product documentation shall incorporate all safety required information to conform to certifiers and regulators and the certifications issued for the product.

### 6.1.5 Product Ecology Requirements

All materials, parts and subassemblies must not contain restricted materials as defined in Intel's Environmental Product Content Specification of Suppliers and Outsourced Manufacturers – <http://supplier.intel.com/ehs/environmental.htm>.

All plastic parts shall not use brominated flame retardant or any other halogenated retardants that are not accepted by environmental programs such as Blue Angels, Nordic White Swan, and Swedish TCO.

All plastic parts that weigh >25gm shall be marked with the ISO11469 requirements for recycling. Example >PC/ABS< .

Packaging materials may not contain more than 100 ppm (total) of lead, cadmium, chromium or mercury.

If sold as a retail product, packaging materials must be marked with applicable recycling logos for Europe (green dot) and Japan (Eco-marks).

Product documentation shall incorporate all safety required information to conform to certifiers and regulators and the certifications issued for the product.

All cords and cables shall contain < 100 ppm of cadmium.

## 6.2 Restriction of Hazardous Substances (RoHS)

Intel has a system in place to restrict the use of banned substances in accordance with the European Directive 2002/95/EC. Compliance is based on declaration that materials banned in the RoHS Directive are either (1) below all applicable substance threshold limits or (2) an approved/pending RoHS exemption applies.

**Note:** *RoHS implementing details are not fully defined and may change.*

Threshold limits and banned substances are noted below.

- Quantity limit of 0.1% by mass (1000 PPM) for:
  - o Lead
  - o Mercury
  - o Hexavalent Chromium
  - o Polybrominated Biphenyls Diphenyl Ethers (PBDE)
- Quantity limit of 0.01% by mass (100 PPM) for:
  - o Cadmium

## 7. Environmental Limits

---

### 7.1 System Office Environment

**Table 18. Intel® Storage System SSR212MA System Office Environment Summary**

Parameter	Limits
Operating Temperature	10 degrees celcius to +35 degrees celcius with the maximum rate of change not to exceed 10 degrees celcius per hour.
Non-Operating Temperature	-40 degrees celcius to +70 degrees celcius
Non-Operating Humidity	95%, non-condensing at 35 degrees celcius
Acoustic noise	7.0 BA (Rackmount) in an idle state at typical office ambient temperature. (23 ± degrees celcius)
Operating Shock	No errors with a half sine wave shock of 2 Giga (1.024 x 10 <sup>9</sup> ) (G) (with 11 millisecond duration)
Package Shock	Operational after a 30 inch free fall, although cosmetic damage may be present (chassis weight 30 lbs)
Electrostatic Discharge (ESD)	±15 Kilovolt (KV) per Intel® Environmental test specification
System Cooling Requirement in British Thermal Units (BTU) per Hour	2275 BTU/hour

### 7.2 System Environmental Testing

The system has been tested per the *Intel® Environmental Standards Handbook*, Intel document number 662394-03. These tests include:

- Temperature Operating and Non-Operating
- Humidity Non-Operating
- Packaged and Unpackaged Shock
- Packaged and Unpackaged Vibration
- AC Voltage, Frequency and Source Interrupt
- AC Surge
- Acoustics
- ESD
- EMC Radiated Investigation

### 7.3 Environmental Limits

The following table summarizes environmental limits, both operating and non-operating.

**Table 19. Intel® Storage System SSR212MA Operating and Non-Operating Environmental Limits**

<b>Temperature</b>	<b>Specification</b>
Non-operating	-40 degrees celcius to 70 degrees celcius
Operating Temperature	10 degrees celcius to 35 degrees celcius
Thermal Map	Must not exceed maximum Integrated Circuit (IC) junction temperature as specified in the component data sheets (CPDs).
<b>Thermal Shock</b>	<b>Specification</b>
Non-operating	-40 degrees celcius to 70 degrees celcius
<b>Humidity</b>	<b>Specification</b>
Non-operating	92% Relative Humidity (RH) at +50 degrees celcius
<b>Vibration</b>	<b>Specification</b>
Non-Operating:	2.2 Grms 5-500Hz for the unpackaged and 1.09 Grms 5-500Hz for the packaged.
<b>Shock</b>	<b>Specification</b>
Non-operating	25 G, 11 millisecond (msec)
<b>ESD</b>	<b>Specification</b>
Operating	Test (air) to 15 KV and (contact) to 2-8KV with limited errors.
<b>EMI</b>	<b>Specification</b>
Operating	Required to meet EMI emission requirements, tested as part of system.

## 8. Serviceability and Availability

---

The system is designed to be serviced by qualified technical personnel only.

The desired Mean Time To Repair (MTTR) of the system is TBD minutes, including diagnosis of the system problem. To meet this goal, the system enclosure and hardware have been designed to minimize the MTTR.

Below are the maximum times that a trained field service technician should take to perform the listed system maintenance procedures, after diagnosis of the system, and with the system powered down and unplugged.

- Remove top cover 0.5 minutes
- Remove and replace a hard disk drive 0.5 minutes
- Remove and replace power supply 0.5 minutes
- Remove and replace fan assembly 1 minute
- Remove and replace SATA add-in cards 5 minutes
- Remove and replace baseboard 10 minutes

## 9. Calculated MTBF

---

The Mean Time Between Failures (MTBF) for the Storage System SSR212MA is calculated at 27,196 hours operating at 40 degrees C. The following table shows the MTBF numbers for individual components within the chassis, and does not include hard disk drives.

**Table 20. Intel® Storage System SSR212MA Component MTBF Numbers**

<b>Subassembly</b>	
<b>(System in 40 °C ambient air)</b>	<b>MTBF (hours)</b>
System Board (SE7520JR2)	215,000
500 W Power Supply	126,710
DOM	1,000,000
Hot Swap SATA Backplane	1,126,100
Fan Tray & Interposer	35,143,386
Fans (5x)	236,340
Front Panel Ops board	53,037,303
SRCS28X SATA Eight Channel RAID adapter	470,000
Battery Backup Unit for SRCS28X SATA Eight Channel RAID adapter	1,800,000





## ***Appendix A: Spares and Accessories***

### **Upgrade and Accessory Parts**

Please refer to the *SSR212MA Configuration Guide* document for the latest order information for spares and accessories, available from IBL or [support.intel.com](http://support.intel.com).

## Glossary

Word / Acronym	Definition
A	Ampere
AC	Alternating Current
ACA	Australian Communication Authority
ACPI	Advanced Configuration and Power Interface
ANSI	American National Standards Institute
ATA	AT Attachment
BA	Decibel Average
BMC	Baseboard Management Controller
BTU	British Thermal Units
C	Celsius
CF	Compact Flash®
CMOS	Complementary Metal Oxide Silicon
CPD	Component Data Sheet
D2D	DC-to-DC
dBA	Decibel Average
DDR	Double Data Rate
DIMM	Dual Inline Memory Module
DMA	Direct Memory Access
DOM	Disk On Module
ECC	Error Correcting Code
EEB	Entry-Level Electronics Bay
EEPROM	Electrical Erasable Programmable Read-Only Memory
EMC	Electro Magnetic Compatibility
EMP	Emergency Management Port
ESD	Electrostatic Discharge
FC	Fibre Channel
FP	Front Panel
FRB	Fault Resilient Boot
FRU	Field Replaceable Unit
FW	Firmware
FWH	Firmware Hub
G	Giga (1.024 x 10 <sup>9</sup> )
GB	Gigabyte
Gb/s	Gigabits per Second
GHz	Gigahertz
HBA	Host Bus Adapter
HDD	Hard Disk Drive
HSBP	Hot Swap Backplane
Hz	Hertz
IBL	Intel Business Link

IC	Integrated Circuit
ICH	I/O Controller Hub
IDC	Internet Database Connector
IDE	Integrated Drive Electronics
IMM	Intel® Management Module
I/O	Input/Output
iSCSI	Internet Protocol Small Computer System Interface
ITE	Information Technology Equipment
K	Kilo (1.024 x 10 <sup>3</sup> )
KB	Kilobyte
KV	Kilovolt
KHz	Kilohertz
LAN	Local Area Network
LED	Light-Emitting Diode
LPC	Low-Pin Count
MB	Megabyte
Mb/s	Megabits per second
MCH	Memory Controller Hub
MHz	Megahertz
mm	Millimeter
msec	Millisecond
MTBF	Mean Time Between Failure
MTTR	Mean Time to Repair
NIC	Network Interface Card
OTP	Over-Temperature Protection
OVP	Over-Voltage Protection
PCI	Peripheral Component Interconnect
PDB	Power Distribution Board
PFC	Power Factor Correction
PIO	Programmed Input/Output
PLD	Programmable Logic Device
PSON	Power Supply On
PSU	Power Supply Unit
PWT	Processor Wind Tunnel
RAID	Redundant Array of Inexpensive Disks
RH	Relative Humidity
RI	Ring Indicate
RoHS	Restriction of Hazardous Substances
SAN	Storage Area Network
SATA	Serial AT Attachment (aka., Serial ATA)
SCA	Single Connector Attachment
SCC	Storage Control Console
SDR	Sensor Data Record
SDRAM	Synchronous Dynamic Random Access Memory
SE	Single-Ended

SMBIOS	System Management Basic Input/Output System
SOIC	Small Outline Integrated Circuit
SRAM	Static Random Access Memory
SSI	Server System Infrastructure
TQFP	Thin Quad Flat Pack
TB	Terabyte
UART	Universal Asynchronous Receiver Transmitter
μF	Micro Farad (1 x 10 <sup>-6</sup> Farads)
μS	Micro Second (1 x 10 <sup>-6</sup> Second)
USB	Universal Serial Bus
V	Volt
VA	Volt-Amp
VCCI	Voluntary Control Council for Interference
VQFP	Very Thin Quad Flat Pack
VRM	Voltage Regulator Module
W	Watt