



***FASTTRAK SX4030,  
SX4060, S150 SX4-M  
USER MANUAL***

Version 1.1

## Copyright

© 2004 Promise Technology, Inc. All Rights Reserved.

Copyright by Promise Technology, Inc. (Promise Technology). No part of this manual may be reproduced or transmitted in any form without the expressed, written permission of Promise Technology.

## Trademarks

Promise, and the Promise logo are registered in U.S. Patent and Trademark Office. All other product names mentioned herein may be trademarks or registered trademarks of their respective companies.

## Important data protection information

You should back up all data before installing any drive controller or storage peripheral. Promise Technology is not responsible for any loss of data resulting from the use, disuse or misuse of this or any other Promise Technology product.

## Notice

Although Promise Technology has attempted to ensure the accuracy of the content of this manual, it is possible that this document may contain technical inaccuracies, typographical, or other errors. Promise Technology assumes no liability for any error in this publication, and for damages, whether direct, indirect, incidental, consequential or otherwise, that may result from such error, including, but not limited to loss of data or profits.

Promise Technology provides this publication “as is” without warranty of any kind, either express or implied, including, but not limited to implied warranties of merchantability or fitness for a particular purpose.

The published information in the manual is subject to change without notice. Promise Technology reserves the right to make changes in the product design, layout, and driver revisions without notification to its users.

This version of the User Manual supersedes all previous versions.

## Radio Frequency Interference Statement

This equipment has been tested and found to comply with the limits for a Class B digital device, pursuant to Part 15 of the FCC Rules. These limits are designed to provide reasonable protection against harmful interference in a residential installation. This equipment generates, uses and can radiate radio frequency energy, and, if not installed and used in accordance with the instruction may cause harmful interference to radio communications. However, there is no guarantee that interference will not occur in a particular installation. If this equipment does cause harmful interference to radio or television reception, which can be determined by turning the equipment off and on, the user is encouraged to try to correct the interference by one or more of the following measures:

- Reorient or relocate the receiving antenna.
- Increase the separation between the equipment and receiver.
- Connect the equipment into an outlet on a circuit different from that to which the receiver is connected.
- Consult Promise Technology, Inc. or an experienced radio/TV technician for help.

This device complies with Part 5 of the FCC Rules. Operation is subject to the following conditions: (1) This device may not cause harmful interference, and (2) this device must accept any interference received, including interference that may cause undesired operation.



### Caution

---

Only digital device equipment CERTIFIED CLASS B should be attached to this equipment and that must have shielded cables.

---



# Contents

<b>Chapter 1: Introduction</b> .....	<b>1</b>
About This Manual .....	1
Product Overview .....	2
Promise Array Management Utility (PAM) .....	3
<b>Chapter 2: Installation</b> .....	<b>5</b>
Installing the FastTrak Card .....	7
Installing the Disk Drives .....	8
<b>Chapter 3: FastBuild™ Utility</b> .....	<b>13</b>
Setup Quick Reference .....	13
Setup Checklist .....	13
Common Tasks .....	13
Enter the FastBuild Utility .....	14
Create an Array .....	14
Delete an Array .....	14
FastTrak BIOS Reference .....	15
Main Menu .....	16
View Drive Assignments .....	17
Define Array .....	18
Define Array Definition Menu .....	19
Create a RAID 0 Array .....	20
Change Stripe Block Size .....	20
Assign Drives to a RAID 0 Array .....	20
Set Gigabyte Boundary .....	20
Save Array Information .....	20
Create a RAID 1 Array .....	21
Create a Mirroring Array with Two New Drives .....	21
Change the Stripe Block Size .....	21
Set Gigabyte Boundary .....	21
Save Array Information .....	21
Create a RAID 0+1 Array .....	22
Assign Drives to a RAID 0+1 Array .....	22
Define the Array as a RAID 0+1 .....	22
Change the Stripe Block Size .....	22
Set Gigabyte Boundary .....	22
Save Array Information .....	22

Create a RAID 5 Array . . . . .	23
Change Stripe Block Size for RAID 5 Array . . . . .	23
Assign Drives to a RAID 5 Array . . . . .	23
Set Gigabyte Boundary . . . . .	23
Save Array Information . . . . .	23
Hot Spare Drives . . . . .	24
Partition and Format Array . . . . .	24
Set Disk Array as Bootable . . . . .	25
Disk Array Recognition Order . . . . .	26
Saved Disk Array Information . . . . .	26
Delete Array . . . . .	27
Controller Configuration . . . . .	28

**Chapter 4: Installing Software Drivers . . . . . 29**

Windows Server 2003	
Install Driver During New OS Installation . . . . .	30
Install Driver in an Existing System . . . . .	31
Confirm Installation . . . . .	32
Windows XP	
Install Driver During New OS Installation . . . . .	33
Install Driver in an Existing System . . . . .	34
Confirm Installation . . . . .	34
Windows 2000	
Install Driver During New OS Installation . . . . .	35
Install Driver in an Existing System . . . . .	36
Confirm Installation . . . . .	36
Red Hat Linux 8.0, 9.0	
Install Driver During New OS Installation . . . . .	37
Install Driver in an Existing System . . . . .	37
SuSE Linux 8.1, 8.2	
Install Driver During New OS Installation . . . . .	38
Install Driver in an Existing System . . . . .	38
FreeBSD 4.x	
Install Driver During New OS Installation . . . . .	39
Specify SX4030 or SX4060 as a SCSI Device . . . . .	39
Promise RAID Utility . . . . .	40

---

<b>Chapter 5: Disk Array Concepts</b> .....	<b>.41</b>
About FastTrak .....	.41
About Adapter BIOS .....	.41
Reserve Sector .....	.41
Disk Array Terms .....	.41
Description .....	.41
Member .....	.42
Types .....	.42
About RAID Levels .....	.43
RAID 0 (Stripe) .....	.43
RAID 1 (Mirror) .....	.44
RAID 0+1 (Stripe/Mirror) .....	.45
About Dual Data Redundancy .....	.46
RAID 5 (Block and Parity Striping) .....	.47
JBOD – Single Drive .....	.48
<b>Chapter 6: Troubleshooting &amp; Tips</b> .....	<b>.49</b>
Motherboard Issues .....	.49
System CMOS Issues .....	.50
Drive-Related Errors .....	.50
Operating System-Related Issues .....	.53
Performance Tips .....	.54
<b>Chapter 7: Support</b> .....	<b>.55</b>
Frequently Asked Questions .....	.55
Pre-Installation (Speed, Device Types, Capacity, Cabling) ..	.55
Drive Issues .....	.57
Installation Issues (Capacity, Booting) .....	.59
Post-Installation .....	.60
Contact Technical Support .....	.60
Limited Warranty .....	.62
Return Product For Repair .....	.63
<b>Appendix A: Memory Upgrade Test</b> .....	<b>.65</b>





# Chapter 1: Introduction

- About This Manual, below
- Product Overview, page 2
- Promise Array Management, page 3

---

Thank you for purchasing one of Promise Technology's FastTrak SX4030, SX4060 or S150 SX4-M RAID controllers.

## About This Manual

This *User Manual* describes how to setup, use and maintain the FastTrak RAID controller. It also describes how to use the Promise Array Management (PAM) RAID management software.

This manual includes a full table of contents, chapter task lists and numerous cross-references to help you find the specific information you are looking for.

Also included are four levels of notices:



---

### Note

A *Note* provides helpful information such as hints or alternative ways of doing a task.

---



---

### Important

An *Important* calls attention to an essential step or point required to complete a task. Important items include things often missed.

---



---

### Caution

A *Caution* informs you of possible equipment damage or loss of data and how to avoid them.

---



---

### Warning

A *Warning* notifies you of probable equipment damage or loss of data, or the possibility of physical injury, and how to avoid them.

---

## **Product Overview**

FastTrak SX4030 and SX4060 are ATA RAID controllers. The FastTrak S150 SX4 is a Serial ATA RAID controller. When used with Promise Array Management (PAM), the FastTrak RAID Controllers offer a feature-rich, secure and versatile enterprise-wide ATA RAID solution. In addition, the FastTrak 4060 and S150 SX4-M support RAID expansion. The resulting RAID environment allows users and administrators to configure, manage, and monitor everything from single arrays on local systems to array networks residing in offsite locations.

The FastTrak S150 SX4-M RAID Controller card supports Serial ATA hard drives. The FastTrak SX4030 and SX4060 RAID Controller cards support (Parallel) ATA hard drives. At their core, all three FastTrak cards provide advanced RAID management functions: creating arrays, monitoring them, keeping them online and operating at optimum efficiency. FastTrak can also perform many other tasks, such as:

- Create arrays at various RAID levels (0, 1, 0+1, 5 and JBOD), depending on the application being used
- Set up a network of FastTrak RAID servers (all running under different RAID levels) and monitor those servers from any workstation on the network
- Create a series of FastTrak RAID networks at any number of offsite locations
- Monitor and/or repair FastTrak RAID arrays using the Internet from an offsite location—all without compromising the integrity of secure servers

## **XOR Acceleration**

The FastTrak S150 SX4-M, SX4030 and SX4060 Controllers have a Hardware XOR accelerator, which offloads the parity calculation workload from the main CPU and transfers it to the controller card, boosting the performance of the entire system.

## **Hot-Swapping**

Each FastTrak S150 SX4-M can support up to four Serial ATA disk drives while each FastTrak SX4030 and SX4060 can support up to four (Parallel) ATA disk drives. With either Controller card the drives configured as RAID levels 1, 0+1, or 5. Attached drives can be *hot swapped* when used with the optional Promise SuperSwap drive enclosures.

## ***Promise Array Management Utility (PAM)***

The Promise Array Management (PAM) utility offers local and remote management and monitoring of all FastTrak arrays that exist anywhere on a network. Windows-based GUI provides email notification of all major events/alarms, memory cache management, logging for NT/2000 servers, array maintenance, rebuild, and access to all components in array (server, controller, data channels, individual drives, and enclosure). For information on using PAM, refer to the *PAM User Manual*, which is included on the CD.



# Chapter 2: Installation

- Package lists, below
  - Installing the FastTrak card, page 7
  - Installing the Disk Drives, page 8
- 

## **S150 SX4-M**

When you receive the FastTrak S150 SX4-M card, the package should contain the items listed below:

- FastTrak S150 SX4-M RAID Controller Card
- 64 MB SDRAM DIMM Memory Card
- Quick Start Guide
- FastTrak driver diskette
- Four internal 4-wire Serial ATA hard drive data cables
- Two Y power splitter cables
- CD with Drivers, Promise Array Management (PAM) utility, *PAM User Manual* and *FastTrak SX4030, SX4060, S150 SX4-M User Manual*

If ANY of the contents are missing or appear to be damaged, please contact your dealer or distributor immediately.

## **SX4030 / SX4060**

When you receive the FastTrak (SX400) Series card, the package should contain the items listed below:

- FastTrak SX4000 Series Controller Card
- 64 MB SDRAM DIMM Memory Card
- Quick Start Guide
- FastTrak driver diskette
- Four Internal 18 inch (46 cm) Ultra ATA, 80-wire/40-pin hard drive cables
- Two Y-cable power splitters
- CD with Drivers, Promise Array Management (PAM) utility, *PAM User Manual* and *FastTrak SX4030, SX4060, S150 SX4-M User Manual*

If any of the items are missing or appear damaged, please contact your dealer or distributor immediately.



---

### Warning

---

The electronic components on the FastTrak RAID Controller card are sensitive to damage from Electro-Static Discharge (ESD). Observe appropriate precautions at all times when handling the FastTrak card or its subassemblies.

---



---

### Warning

---

Before installing the adapter into an existing system, backup any important or useful data. Failure to follow this accepted PC practice could result in data loss.

---



---

### Important

---

In place of the 64 MB SDRAM DIMM included with the FastTrak card, you can install a SDRAM DIMM of up to 256 MB for additional capacity and performance. Promise provides a list of approved DIMMS and a testing procedure to ensure compatibility. See Appendix A in this *User Manual*.

---



---

### Notes

---

The FastTrak SX4030, SX4060 and S150 SX4-M RAID Controller cards are PCI Plug-n-Play (PnP) devices. No changes are necessary in the motherboard CMOS/BIOS Setup for resources or drive types in most applications.

---

## Installing the FastTrak Card

The FastTrak RAID Controller card fits into any available:

- 32-bit PCI slot (must be PCI 2.2 compliant)
- The 32-bit portion of a 64-bit PCI slot

on the PC's motherboard (see Figure 1 below).

1. Remove the cover of your system.
2. Remove the inside slot cover of an available 32-bit PCI slot on the motherboard.

Note: FastTrak SX4030 supports only a 33-MHz PCI slot.

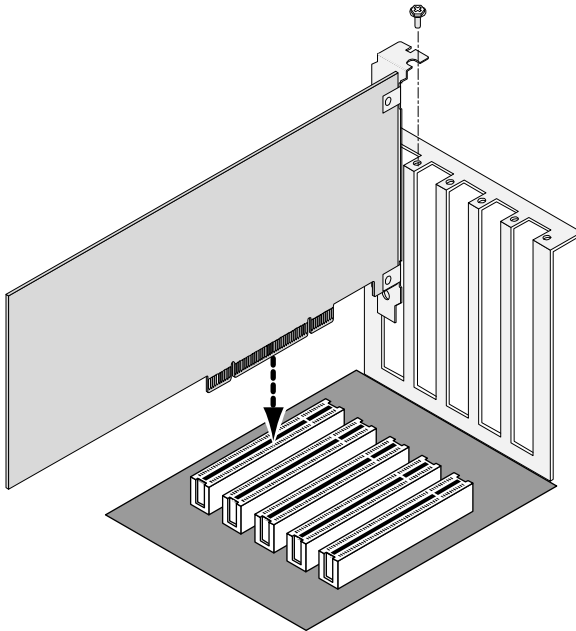

3. Install the FastTrak card into the open slot (above). Secure the bracket to the system's frame.
4. Attach your system case's 2- or 4-pin LED cable to the LED connector on the FastTrak card (see Figures 2 and 3, below). Make sure that pin 1 on the connector is aligned with pin 1 of the cable.
5. Fasten the FastTrak card bracket to the system case (see below).

## Installing the Disk Drives



### Important

---

If you wish to include your current bootable Serial ATA drive using the Windows operating system as part of a bootable Mirrored (RAID 1) array on your FastTrak card, do NOT connect the hard drive to the FastTrak yet. You MUST install the Windows driver software first onto this drive while it is still attached to your existing hard drive controller.

---

The FastTrak S150 SX4 RAID Controller card supports only Serial ATA hard drives. The FastTrak SX4030 and SX4060 RAID Controller cards support only (Parallel) ATA disk drives. For optimal performance, install disk drives of the same model and capacity. The drives' matched performance allows the array to function better as a single drive.

If you are striping (RAID 0) for performance, use up to four new drives. If mirroring (RAID 1) for protection, you can use two new drives OR use an existing drive and a new drive (the new drive must be the same size or larger than the existing drive). If you are planning a RAID 5 array, use three or four new drives.

1. SX4030 / SX4060 only: Set your hard drives to Master, Cable-Select or Single (depending on drive specification). The Serial ATA Specification excludes Master/Slave settings, so these do not apply to the S150 SX4 card.
2. Install the hard drives into the hard drive bays of your system.



### Caution

---

Use of removable hard drive enclosures other than Promise Technology's SuperSwap is not supported and may result in performance loss or other undesired results.

---



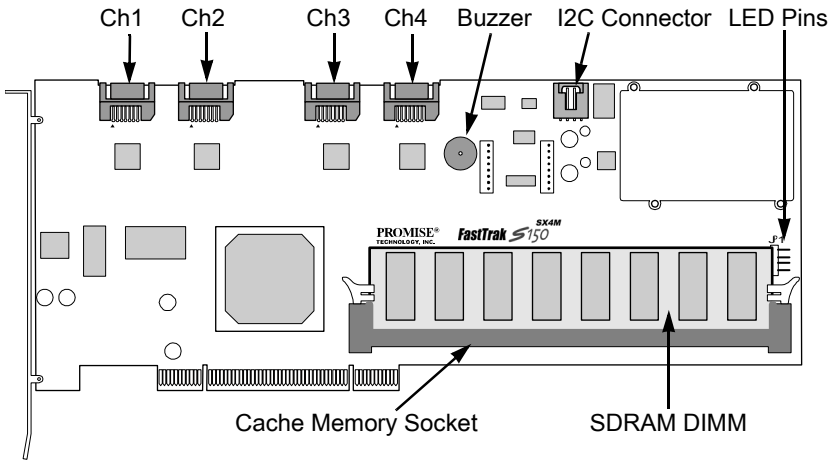

3. S150 SX4-M: Attach one Serial ATA data cable to each hard drive. Then attach the other ends of the cables to the connectors on the FastTrak card (above).

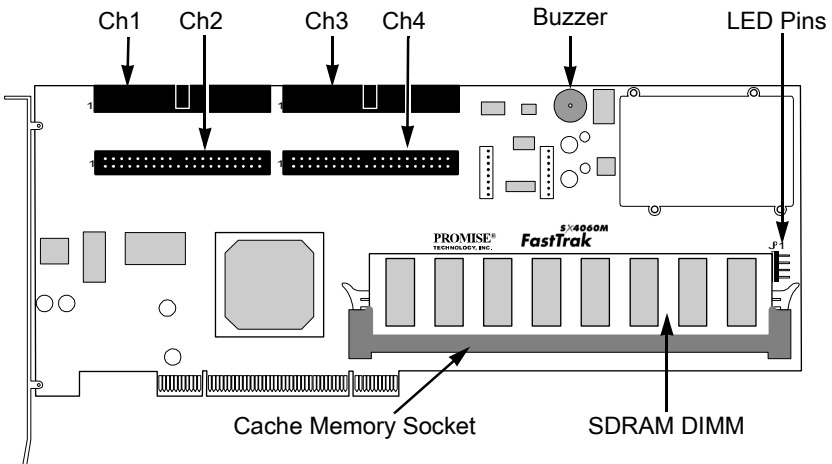

SX4030 / SX4060: Attach the black end of the Ultra ATA cable to each hard drive. Then attach the blue end to the ATA connectors on the FastTrak card (above).

4. Attach the Y-cable power splitters to each of the hard drives.

You will now use the onboard FastBuild BIOS utility to create your first array using the attached drives. For an explanation of the array options, see Chapter 3 of this manual.



### Important

---

Even if you plan to use the Promise Array Management Utility to manage your array, you must still create your first array using the FastBuild Utility, as described here.

---

1. Boot your system. If this is the first time you have booted with the FastTrak card and drives installed, the Promise onboard BIOS will display the following screen (below).

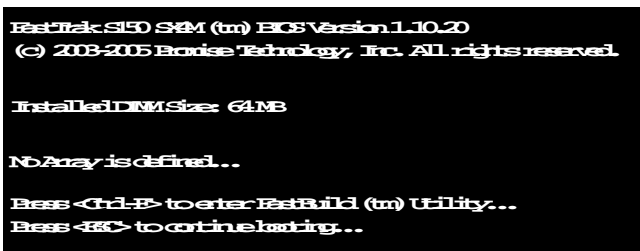

2. Press the Ctrl-F keys to display the FastBuild Utility Main Menu (below).

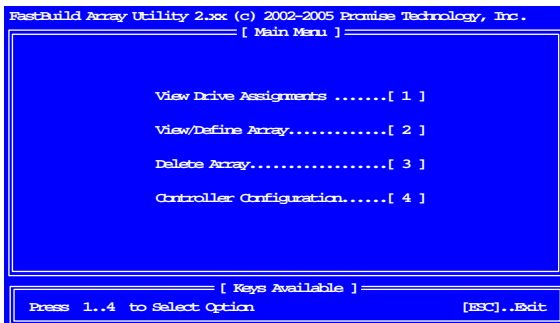

- Press 2 on the Main Menu screen to display, the Define Array Menu appears (below).

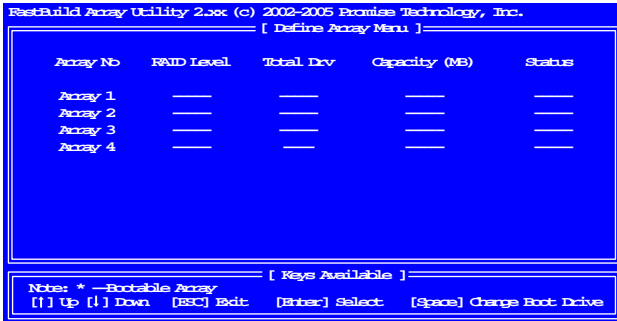

- Press the arrow keys to highlight an array number you wish to define and press Enter to select it. The Define Array Definition Menu will next appear (below).

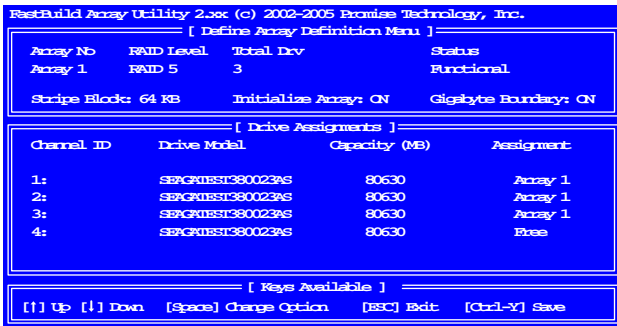

- Choose the RAID Level you want. In the Define Array Definition Menu section, press the Spacebar to cycle through array types:
  - RAID 0 (Stripe)
  - RAID 1 (Mirror)
  - RAID 0+1 (Stripe / Mirror)
  - RAID 5 (Data / Parity Stripe)
  - JBOD (Single Drive)
- Press the arrow keys to move to the next option. Option choices depend on the RAID Level you selected.
  - Initialize Array, zero the disk drives. RAID 5 only.
  - Stripe Block Size, the default 64KB is best for most applications.
  - Gigabyte Boundary, allows use of slightly smaller replacement drives.

7. Press the arrow keys to move to Disk Assignments. Press the spacebar to toggle between N and Y for each available drive.
8. Assign the appropriate number of disk drives to your array. Refer to the chart below:

Level	Number of Drives
RAID 0	2, 3 or 4
RAID 1	2 only
RAID 0+1	4 only
RAID 5	3 or 4
JBOD	1, 2, 3 or 4

A disk drive that is not assigned to an array will automatically function as a Hot Spare Drive.

9. Press Ctrl-Y to save your array configuration.
10. Press Esc to exit to the Main Menu. Press Esc again to exit the Utility.
11. Press Y to confirm the new array and restart the computer.

You have successfully created a new RAID array.



---

### Important

You must be partition and format your new array before you can use it. Use the same method of partitioning and formatting on an array as you would any other fixed disk added to your computer system.

---

## Chapter 3: FastBuild™ Utility

- Setup Quick Reference, below
- FastTrak BIOS Reference, page 15
- Main Menu, page 16
- View Drive Assignments, page 17
- Define (Create) Array, page 18
- Array Definition Menu, page 19
- Delete Array, page 27
- Controller Configuration, page 28

---

This chapter contains a Setup Quick Reference that is a checklist of tasks needed to initialize your FastTrak SX4030, SX4060 or S150 SX4-M system, followed by a step-by-step instructional breakdown of each task. The second half of this chapter is a visual and technical description reference including software screen shots.

### ***Setup Quick Reference***

Use this reference to make sure you have completed all the tasks necessary to get your FastTrak SX4030, SX4060 or S150 SX4-M server running. See Chapter 5 for more information on RAID arrays.

### **Setup Checklist**

- Power up the system and watch for the Promise FastTrak BIOS messages.
- When prompted, press Ctrl-F to enter the FastBuild utility.
- If you are defining more than one array and booting from one of these arrays, go to the Define Array menu. Press the Up and Down Arrow keys to highlight the array then press the Spacebar to make it bootable.
- Restart the system for the changes to take effect.
- Watch for the Promise FastTrak BIOS messages, ensuring that the messages reflect the array(s) you have created.

### **Common Tasks**

The following is a listing of steps necessary to complete each type of task required for setting up the FastTrak SX4030, SX4060 or S150 SX4-M system through the FastBuild BIOS utility. The tasks are not intended to be a complete, step-by-step guide to setting up the FastTrak system successfully.



### Note

---

There are some advanced RAID array configuration options that require the PAM utility to set up.

---

## Enter the FastBuild Utility

When the system boots, you will see the Promise FastTrak BIOS sign-on banner appear on the screen. Once the BIOS identifies the arrays attached to the FastTrak Controller card, it will offer an option to enter the FastBuild utility.

Press Ctrl-F to enter FastBuild utility and display the Main Menu (see page 16).

## Create an Array

1. In the Main Menu press 2 to display the Define Array screen (see page 18).
2. In the Define Array screen, select the array number you want to define using the arrow keys, and press Enter to display the Define Array Definition Menu screen.
3. In the Define Array Definition menu (see page 19), highlight the RAID Level column using the Tab key, and then cycle through the choices using the Spacebar to select the RAID level you wish to use for the new array.
4. In the Drive Assignments menu (see page 17), press the Down Arrow to select from the available drives to assign them as members of the new array. Use the Spacebar to toggle between Yes or No or press Y under the Assignment column to assign the drive; N un-assigns the drive.
5. When you are finished assigning drives as array members, press the Ctrl-Y keys to save the array member assignment. The utility will return to the Define Array Definition Menu screen and the new array will now be visible in the list.

## Delete an Array

1. From the Main Menu press 3 to display the Delete Array Menu (see page 27).
2. In the Delete Array Menu, press the Up and Down Arrow keys to highlight the array you wish to delete then press the Del key.
3. Press the Ctrl-Y keys to confirm deletion.

## FastTrak BIOS Reference

When the FastTrak BIOS loads during bootup, it displays pertinent information about the RAID arrays that it finds. Then, it displays Press Ctrl-F to allow you to enter the Array BIOS Configuration Utility (below).

```
FastTrak S150 SX4-M (m) BIOS Version 1.10.20
(c) 2003-2005 Brocade Technology, Inc. All rights reserved.

Installed DIMM Size: 64MB

No Array is defined...

Press <Ctrl-F> to enter FastBuild (tm) Utility...
Press <Esc> to continue booting...
```

Shown is the first-time BIOS Startup for FastTrak S150 SX4-M. The SX4030 / SX4060 is similar. The information displayed in the form of a small table contains the following properties:

**ID** – These represent a unique ID number assigned to each RAID array identified by the BIOS.

**Mode** – This identifies the RAID mode configuration that the array is defined as.

**Size** – This is the MB (Megabyte) data size of the indicated array.

**Track-Mapping** – This is the CHS (Cylinder/Head/Sector) equivalent of the array geometry as hosted by the FastTrak BIOS int 13h disk services.

**Status** – Shows one of three possible array status conditions:

**Functional** – The array is fully operational, and no problems are present.

**Critical** – The array is operational, but has lost its fault tolerance. For RAID array levels 1, 0+1 and 5 the array contains a failed drive. The user must identify and replace the failed drive.

**Offline** – The array is no longer operational and the FastBuild utility cannot rebuild the array. The array must be rebuilt from the last tape backup or other device. The user should identify and replace the failed drives.

For RAID levels 1 and 5, at least two or more drives in the array have failed.

For a RAID 0 or JBOD array, at least one drive has failed.

## Main Menu

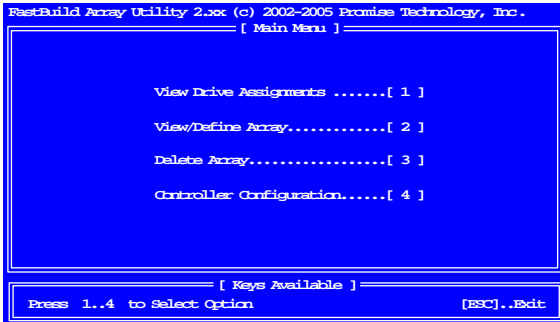

### Note

---

This menu uses number keys 1 through 4 to select options. Many of the subsequent menu windows require you to press arrow-pad keys in order to highlight options. Press the spacebar to cycle through choices for the selected option. Press Enter (return) to select a highlighted option. Press ESC (Escape) to exit the menu.

---

Descriptions of each of the four options from the Main Menu screen (above) appear on the following pages.



## View Drive Assignments

Press 1 on the Main Menu screen, to see the View Drive Assignments screen (below). This screen does not allow modifications to any of the four fields.

```

FastBuild Array Utility 2.0c (c) 2002-2005 Promise Technology, Inc.
[ View Drive Assignments ]

Channel : ID      Drive Model      Capacity      Assignment Mode
CH 1:           SEAGMBS1380023AS  80630        Array1        S
CH 2:           SEAGMBS1380023AS  80630        Array1        S
CH 3:           SEAGMBS1380023AS  80630        Array1        S
CH 4:           SEAGMBS1380023AS  80630        Free          S

Note: * --Bootable Array
[↑] Up [↓] Down [ESC] Edit Mode (S=Serial)
  
```

**Channel: ID** – This field shows the FastTrak Controller channel ID (1-4) to which a particular drive is attached.

**Drive Model** – This field identifies the manufacturer, model, and model number (if applicable) of each drive installed on the FastTrak Controller card.

**Capacity (MB)** – This field reflects the capacity in MB (megabytes) of each drive.

**Assignment** – This field identifies the array to which each drive belongs.

Assigned drives are labeled with their disk array (1, 2, 3, etc?).

Unassigned drives are labeled *free* and are considered *hot spares* to provide fault tolerance. Unassigned drives may also be used to create a new array at any time.

**Mode** – On the FastTrak S150 SX4, this channel uses Serial ATA technology and displays a letter S. It does not apply to the FastTrak SX4030 / SX4060.

## Define Array

Press 2 on the Main Menu screen to display, the Define Array Menu (see below). This screen displays any existing arrays. Users commonly create one or two arrays with FastTrak SX4030, SX4060 or S150 SX4-M.

To manually create arrays from the Define Array Menu (below), press the arrow keys to highlight an array number you wish to define, and press Enter to select it. The Define Array Definition Menu will next appear that allows drive assignments to the disk array (see below).

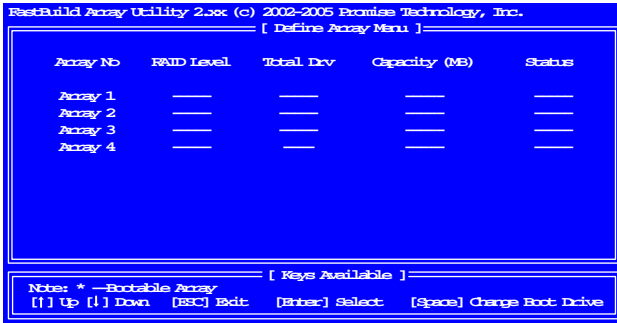

**Array No.** – The Array Number column displays all arrays (defined or undefined) addressable by the FastTrak Controller.

**RAID Level** – This column indicates the RAID type applied to a particular array.  
**Total Drv** This column displays the number of drives configured for the array.

**Capacity (MB)** – This column shows the total capacity in MB (megabytes) for each array.

**Status** – This column displays the status information for each array. See page 14 for status definitions.

## Define Array Definition Menu

Selecting an Array from the Define Array Menu brings up the Define Array Definition Menu screen (below). First, choose the RAID Level you want. In the Define Array Definition Menu section, press the Spacebar to cycle through array types:

- RAID 0 (Striping)
- RAID 1 (Mirroring)
- RAID 0+1 (Striping / Mirroring)
- RAID 5 (Data / Parity Striping)
- JBOD (Single Drive)

See the explanations on the following pages for more information about each RAID Level and the options that come with them.

```

FastBuild Array Utility 2.3c (c) 2002-2005 Promise Technology, Inc.
[ Define Array Definition Menu ]
-----
Array No   RAID Level  Total Drv   Status
Array 1    RAID 5        3             Functional
-----
Stripe Block: 64 KB   Initialize Array: ON   Gigabyte Boundary: ON
-----
[ Drive Assignments ]
-----
Channel ID  Drive Model          Capacity (MB)  Assignment
-----
1:          SEAGMSST380023AS    80630         Array 1
2:          SEAGMSST380023AS    80630         Array 1
3:          SEAGMSST380023AS    80630         Array 1
4:          SEAGMSST380023AS    80630         Free
-----
[ Keys Available ]
-----
[F1] Up [F1] Down [Space] Change Option [ESC] Edit [Ctrl-Y] Save
  
```

**Gigabyte Boundary** – The Gigabyte Boundary feature is designed for fault tolerant arrays (RAID 1, 0+1 and 5) in which a drive has failed and the user cannot replace the drive with the same capacity or larger. Instead, the Gigabyte Boundary feature permits the installation of a replacement drive that is slightly smaller (within 1 gigabyte) than the remaining working drive (for example, an 80.5 GB drive would be rounded down to 80 GB). This can be helpful in the event that a drive fails and an exact replacement model is no longer available.

For the Gigabyte Boundary feature to work, the Gigabyte Boundary feature must be set to ON when the original array is created. When enabled, the Gigabyte Boundary feature rounds the drive capacity of all drives to the common whole GB drive size. For example, with the Gigabyte Boundary feature enabled, the remaining working drives can be 80.5 GB and the replacement drive can be 80.3, since all are rounded down to 80GB. This permits the smaller drive to be used. Please note that users will lose a small amount of available storage capacity from each drive in order to arrive at a common drive size.

## Create a RAID 0 Array

In the Define Array Definition Menu section (see Figure 8), press the Spacebar to cycle through array types and select RAID 0 for RAID Level. Assign from one to four drives to this array. Each member of such an array will no longer be readable as an independent drive if removed from the array. The capacity of the array will equal the capacity of the smallest drive multiplied by the number of drives within the array.

### Change Stripe Block Size

For RAID 0 arrays, the FastTrak Controller will allow you to change the stripe block size. The default is 64K. However, certain application environments may perform optimally with different block size. To change the block size, use the Arrow keys to highlight the field and the Spacebar to cycle through the available size selections (16, 32 or 64K).



#### Note

---

You cannot change the block size after the array has been created.

---

### Assign Drives to a RAID 0 Array

Under the Drive Assignments section, highlight a drive and, with the Spacebar, change the Assignment option to Y to add the drive to the disk array. Press Ctrl-Y to save the disk array information. The initial Define Array Menu screen will appear after you have pressed Ctrl-Y. You will see the array defined. You may select another Array number to define or you may ESC to exit and return to the Main Menu of FastBuild.

### Set Gigabyte Boundary

For RAID 0 arrays, FastTrak sets the Gigabyte Boundary to OFF.

### Save Array Information

Press Ctrl-Y to save the Disk Array Information.

## Create a RAID 1 Array

In the Define Array Definition Menu section, press the Spacebar to cycle through array types and select RAID 1 for RAID Level. RAID 1 arrays use two disk drives. The capacity of the array will be half that of the smaller drive in the array. No stripe block size option is available when mirroring two drives.

### Create a Mirroring Array with Two New Drives

As described above, if you select a mirroring array and wish to use two new drives, follow the directions here. Under the Drive Assignments section, assign both new drives to the array and save the information by pressing Ctrl-Y. Once the process is complete, you will be returned to the Define Array Menu where the array will be shown as defined.



---

#### Note

---

You may choose to attach an unassigned third drive to the FastTrak Controller to act as a hot spare replacement (see Page 26).

---

### Change the Stripe Block Size

For RAID 1 arrays, FastTrak does not permit you to change the Stripe Block size.

### Set Gigabyte Boundary

For RAID 1 arrays, FastTrak allows you to toggle the Gigabyte Boundary ON or OFF. The default is OFF. To toggle Gigabyte Boundary, use the Arrow keys to highlight the field and the Spacebar to toggle between ON and OFF.

### Save Array Information

Press Ctrl-Y to save the Disk Array Information.

## **Create a RAID 0+1 Array**

You must assign four drives to an array before this feature becomes available.

### **Assign Drives to a RAID 0+1 Array**

Under the Drive Assignments section, highlight a drive and, with the Spacebar, change the Assignment option to Y to add the drive to the disk array. Continue to add drives to the array until you assigned all four drives. Press Ctrl-Y to save the disk array information. Press the up arrow to move to RAID Mode.

### **Define the Array as a RAID 0+1**

In the Define Array Definition Menu section, press the Spacebar to cycle through array types and select RAID 0+1 for RAID Level. You will be creating two pairs of striped drives with identical data on them. The capacity of the array will be half that of the total number of mirrored drives within the array.

Save the information with Ctrl-Y. FastBuild automatically creates the RAID 0+1 array and returns you to the Define Array Menu where the array will be shown.

### **Change the Stripe Block Size**

For RAID 0+1 arrays, FastTrak allows you to change the stripe block size. The default is 64K. Press the Arrow keys to highlight the field and the Spacebar to cycle through the available size selections (16, 32, or 64K).

### **Set Gigabyte Boundary**

For RAID 0+1 arrays, FastTrak allows you to toggle the Gigabyte Boundary ON or OFF. The default is ON/OFF. To toggle Gigabyte Boundary, press the Arrow keys to highlight the field and the Spacebar to toggle between ON and OFF.

### **Save Array Information**

Press Ctrl-Y to save the Disk Array Information.

---

## Create a RAID 5 Array

In the Define Array Definition Menu section, press the Spacebar to cycle through array types and select RAID 5 for RAID Mode. You must configure such an array using a minimum of three drives.

Your array will join the assigned drives together and split (or stripe) data among them. Each member of such an array will no longer be readable as an independent drive if removed from the array.

The capacity of the array will equal the capacity of the smallest drive multiplied by one less than the total number of drives assigned to the array.



### Note

---

If you choose to use three drives, an additional unassigned drive can be your hot spare drive in case of drive failure (see below).

---

## Change Stripe Block Size for RAID 5 Array

For RAID 5 arrays, the FastTrak Controller allows you to change the stripe block size. The default is 64K. To change the block size, press the Arrow keys to highlight the field and the Spacebar to cycle through the available size selections.

## Assign Drives to a RAID 5 Array

Under the Drive Assignments section, highlight a drive, and, press the Spacebar to change the Assignment option to Y to add the drive to the disk array. Press Ctrl-Y to save the disk array information. The initial Define Array Menu screen will appear after you have pressed Ctrl-Y. You will see the array defined. You may ESC to exit and return to the Main Menu of FastBuild.

## Set Gigabyte Boundary

For RAID 5 arrays, the FastTrak Controller allows you to toggle the Gigabyte Boundary ON or OFF. The default is OFF. To toggle Gigabyte Boundary, press the Arrow keys to highlight the field and the Spacebar to toggle between ON and OFF.

## Save Array Information

Press Ctrl-Y to save the Disk Array Information.

## Hot Spare Drives

Any extra drive that is not assigned to an array will be recognized as a Spare Drive. Such drives are designated *Free* in the View Drive Assignments screen (see below).

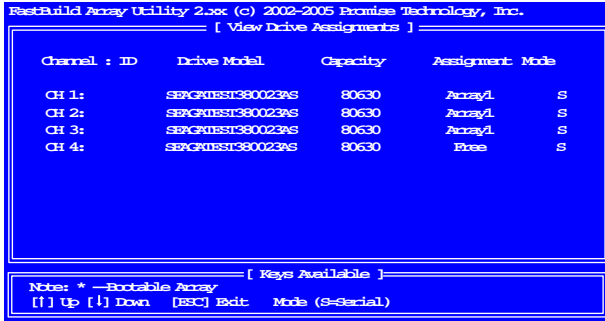

Channel	ID	Drive Model	Capacity	Assignment	Mode
CH 1:		SEAGRMST380023AS	80630	Array1	S
CH 2:		SEAGRMST380023AS	80630	Array1	S
CH 3:		SEAGRMST380023AS	80630	Array1	S
CH 4:		SEAGRMST380023AS	80630	Free	S

Notes: \* -Bootable Array  
 [ ] Up [ ] Down [ESC] Exit Mode (S=Serial)

Spare Drives are automatically added to an array once a disk member of the array has been detected as *failed*. To restore fault tolerance as quickly as possible, the FastTrak Controller performs an automatic data rebuild on the *spare* drive in the background without the need to restart the system. At a later time, the failed drive can be physically removed and an extra drive added in its place to function as the spare drive.

## Partition and Format Array

Your new RAID array must be partitioned and formatted before use. Use the same method of partitioning and formatting on an array as you would any other fixed disk added to your computer system.



## Set Disk Array as Bootable

You may select which defined array will be used as the bootable array from the Define Array Menu (press 2 in the Main Menu). Press the up and down arrow keys to highlight the desired array and press the Spacebar. The system will now recognize this as the first array and an asterisk (\*) will appear next to the array number indicating it as bootable (see below).

```

FastBuild Array Utility 2.0c (c) 2002-2005 Promise Technology, Inc.
[ Define Array Menu ]
  
```

Array No	RAID Level	Total Drv	Capacity (MB)	Status
*Array 1	RAID5	3	161260	Functional
Array 2	---	---	---	---
Array 3	---	---	---	---
Array 4	---	---	---	---

```

  
```

Note: \* --Bootable Array  
 [↑] Up [↓] Down [ESC] Edit [Enter] Select [Space] Change Boot Drive



### Important

You must reconfigure your PC's or server's BIOS in order use FastTrak card as the bootable controller. The system will then use the bootable array as the (fixed) boot C: drive.

## Disk Array Recognition Order

During computer startup, the disk arrays on the FastTrak Controller card are recognized in this order:

- The bootable array, designated in the FastBuild setup.
- Other arrays by their numbers (such as Array 1, Array 2...).

Array Recognition Order determines the order in which each array is assigned the next available drive letter.

By way of example, say that your PC boots from its internal disk drive and has a CD-ROM Drive. In addition, you have a FastTrak S150 TX4 with two arrays, Array1 and Array2. When your system boots, the internal disk drive will be C:, the CD-ROM will be D:, Array1 will be E: and Array2 will be F:.

## Saved Disk Array Information



### Note

---

Promise suggests that you record information about your disk array(s) for future reference.

---

All disk array data is saved within the reserved sector of each arrayed drive. Another feature of the FastTrak disk array system is to recognize drive members even if drives are moved to different channels on the FastTrak Controller card. Since each drive's array data identifies itself to the array, it is possible to reorder the drives without modifying the array setup. This is valuable when adding drives, or during a rebuild.

## Delete Array

Press 3 on the Main Menu screen to display the Delete Array Menu (below).

```

FastBuild Array Utility 2.3ec (c) 2002-2005 Eromiss Technology, Inc.
----- [ Delete Array Menu ] -----
  Array No   RAID Level   Total Drv   Capacity (MB)   Status
-----
*Array 1     RAID5           3           161260          Functional
Array 2     _____     _____     _____         _____
Array 3     _____     _____     _____         _____
Array 4     _____     _____     _____         _____

----- [ Keys Available ] -----
Note: * --Rotable Array
[↑] Up [↓] Down [ESC] Exit [Del.] Delete

```



### Caution

Deletion of an existing disk array could result in the loss of all data from the hard drives of the affected array.

Record all array information, including array type, disk members, and stripe block size, in case you wish to undo a deletion.

Arrays may possibly be recovered after deletion by immediately re-defining the array with information identical to the original configuration.

To delete an array, highlight the Array you wish to delete and press the Del key.

When the following message appears (below), press Ctrl-Y to confirm yes to continue array deletion.

```

Are you sure you want to delete this array?
[Yes/No/Cancel]

```

Press any other key to abort the deletion process.

## Controller Configuration

Press 4 on the Main Menu screen to display the Controller Configuration Options screen (below).

```
FastBuild (tm) Utility 2.00c (c) 2002-2005 Promise Technology, Inc.
===== [ Adapter Configuration Options ] =====
No Parameters Defined for Current Disk(s)...

===== [ System Resources Configuration ] =====
Installed Memory Address: DE100000          Size: 512M
Controller IRQ: 11

ATA IO Address: 9000
XCR and HDMA IO Address: 9400
Sequence Control IO Address: 9800
Flash and SRAM Memory Address: DE000000

===== [ Keys Available ] =====
[ESC] Exit
```

The information in the System Resources Configuration section is for display only. Two items may be useful to the user for troubleshooting

The information presented here is as follows: ? Installed Memory

- Shows the size of the SDRAM DIMM plugged into the FastTrak Controller card.
- Controller IRQ used by the FastTrak card

The other items may be useful if you ever have to contact Technical Support.

# Chapter 4: Installing Software Drivers

Following are driver installation procedures for the FastTrak SX4030, SX4060 or S150 SX4-M RAID Controller cards. Download the latest drivers from the Promise Technology website at [www.promise.com](http://www.promise.com).

<b>Procedure</b>	<b>Page Number</b>
<b>Windows Server 2003</b>	
Install Driver During New OS Installation .....	30
Install Driver in an Existing System .....	31
Confirm Installation .....	32
<b>Windows XP</b>	
Install Driver During New OS Installation .....	33
Install Driver in an Existing System .....	34
Confirm Installation .....	34
<b>Windows 2000</b>	
Install Driver During New OS Installation .....	35
Install Driver in an Existing System .....	36
Confirm Installation .....	36
<b>Red Hat Linux 8.0, 9.0</b>	
Install Driver During New OS Installation .....	37
Install Driver in an Existing System .....	37
<b>SuSE Linux 8.1, 8.2</b>	
Install Driver During New OS Installation: Single Processor .....	38
Install Driver During New OS Installation: Multi-Processor .....	38
Install Driver in an Existing System .....	38
<b>FreeBSD 4.x</b>	
Install Driver During New OS Installation .....	39
Specify SX4030 or SX4060 as a SCSI Device .....	39
Promise RAID Utility .....	40

## **Windows Server 2003**

### **Install Driver During New OS Installation**

1. Start the installation: Boot from the CD-ROM. Press F6 after the message "Press F6 if you need to install third party SCSI or RAID driver" appears.
2. When the Windows Setup window is generated, press S to specify an Additional Device(s)
3. Insert the Promise Technology driver diskette into drive A: and press Enter.
4. Choose *Windows 2003 Promise FastTrak S150 SX4/SX4000 Series* from the list that appears on screen, and then press the Enter. 1. Press S to use the driver on the floppy disk and then press Enter to continue with installation.
5. The Windows 2003 Setup screen will appear again saying "Setup will load support for the following mass storage devices:" The list will include *Windows 2003 Promise FastTrak S150 SX4/SX4000 Series*.  
**Note:** If you need to specify any additional devices to be installed, do so at this time. Once all devices are specified, continue to the next step.
6. From the Windows Setup screen, press the Enter. Setup will now load all device files and then continue the Windows installation.

**Note:** Check the readme file, included with the downloaded driver files, for instructions on installing the RAID Console.

## Install Driver in an Existing System



### Important

---

If you plan to move the boot drive containing the existing Windows Server 2003 operating system to the FastTrak card, you **MUST** load the FastTrak driver to the boot drive while it is still attached to your existing hard drive controller.

Do not attach the boot drive to the FastTrak card before completing this step.

---

After installing the FastTrak card and rebooting your system, Windows setup will show a Found New Hardware dialog box.

1. Insert the Promise FastTrak Driver diskette in the A: drive.
2. When the New Hardware Wizard appears, select *Install from a list or specific location (advanced)* and click *Next*.
3. Under Please choose your search and installation options, select *Don't search. I will choose the driver to install* and click *Next*.
4. Under Select the device driver you want to install, click *Have Disk...*
5. Under Install from Disk, type **A:\wnet** wnet and click *OK*.
6. Under Select the device driver you want to install, click *Next*.
7. If a warning about Windows Logo testing appears, click *Continue Anyway*.
8. Under Completing the Found New Hardware Wizard, click *Finish*.
9. If the New Hardware Wizard appears again, close it.
10. Click *Yes* to restart your PC.
11. Remove the Promise FastTrak Driver diskette.
12. When the Found New Hardware Wizard appears a second time, select *Install the Software Automatically (Recommended)* and click *Next*.
13. If a warning about Windows Logo testing appears, click *Continue Anyway*.
14. Under Completing the Found New Hardware Wizard, click *Finish*.

**Note:** Check the readme file, included with the driver files, for instructions on installing the RAID Console.

## Confirm Installation

1. From the Windows Desktop, open the Control Panel from My Computer.
2. Click on Performance and maintenance.
3. Click on the System icon.
4. Choose the Hardware tab, and then click the Device Manager button.
5. Click the + in front of SCSI controllers. *Windows 2003 Promise FastTrak S150 SX4/SX4000 Series* should appear.



## **Windows XP**

### **Install Driver During New OS Installation**

1. Start the installation: Boot from the CD-ROM. Press F6 after the message "Press F6 if you need to install third party SCSI or RAID driver" appears.
2. When the Windows Setup window is generated, press S to specify an Additional Device(s)
3. Insert the Promise Technology driver diskette into drive A: and press Enter.
4. Choose *WinXP Promise FastTrak S150 SX4/SX4000 Series* from the list that appears on screen, and then press the Enter. 1. Press S to use the driver on the floppy disk and then press Enter to continue with installation.
5. The Windows XP Setup screen will appear again saying "Setup will load support for the following mass storage devices:" The list will include *WinXP Promise FastTrak S150 SX4/SX4000 Series*.

**Note:** If you need to specify any additional devices to be installed, do so at this time. Once all devices are specified, continue to the next step.

6. From the Windows Setup screen, press the Enter. Setup will now load all device files and then continue the Windows XP installation.

**Note:** Check the readme file, included with the downloaded driver files, for instructions on installing the RAID Console.

## Install Driver in an Existing System



### Important

---

If you plan to move the boot drive containing the existing Windows Server 2003 operating system to the FastTrak card, you **MUST** load the FastTrak driver to the boot drive while it is still attached to your existing hard drive controller.

Do not attach the boot drive to the FastTrak card before completing this step.

---

After installing the FastTrak card and rebooting your system, Windows setup will show a Found New Hardware dialog box.

1. Insert the Promise FastTrak Driver diskette in the A: drive.
2. When the New Hardware Wizard appears, select *Install from a list or specific location (advanced)* and click *Next*.
3. Under Please choose your search and installation options, select *Don't search. I will choose the driver to install* and click *Next*.
4. Under Select the device driver you want to install, click *Have Disk...*
5. Under Install from Disk, type **A:\winxp** and click *OK*.
6. Under Select the device driver you want to install, click *Next*.
7. If a warning about Windows Logo testing appears, click *Continue Anyway*.
8. Under Completing the New Hardware Wizard, click *Finish*.
9. If the New Hardware Wizard appears again, close it.
10. Click *Yes* to restart your PC.
11. Remove the Promise FastTrak Driver diskette.

**Note:** Check the readme file, included with the downloaded driver files, for instructions on installing the RAID Console.

## Confirm Installation

1. From the Windows Desktop, open the Control Panel from My Computer.
2. Click on Performance and maintenance.
3. Click on the System icon.
4. Choose the Hardware tab, and then click the Device Manager button.
5. Click the + in front of SCSI controllers. *WinXP Promise FastTrak S150 SX4/SX4000 Series* should appear.

## **Windows 2000**

### **Install Driver During New OS Installation**

1. Start the installation: Boot from the CD-ROM. Press F6 after the message "Press F6 if you need to install third party SCSI or RAID driver" appears.
2. When the Windows Setup window is generated, press S to specify an Additional Device(s)
3. Insert the Promise Technology driver diskette into drive A: and press Enter.
4. Choose *Win2000 Promise FastTrak S150 SX4/SX4000 Series* from the list that appears on screen, and then press the Enter.
5. The Windows Setup screen will appear again saying "Setup will load support for the following mass storage devices:" The list will include *Win2000 Promise FastTrak S150 SX4/SX4000 Series*.  
**Note:** If you need to specify any additional devices to be installed, do so at this time. Once all devices are specified, continue to the next step.
6. From the Windows Setup screen, press the Enter. Setup will now load all device files and then continue the Windows installation.

**Note:** Check the readme file, included with the downloaded driver files, for instructions on installing the RAID Console.

## Install Driver in an Existing System



### Important

---

If you plan to move the boot drive containing the existing Windows Server 2003 operating system to the FastTrak card, you **MUST** load the FastTrak driver to the boot drive while it is still attached to your existing hard drive controller.

Do not attach the boot drive to the FastTrak card before completing this step.

---

After installing the FastTrak card and rebooting your system, Windows setup will show a Found New Hardware dialog box.

1. When the New Hardware Wizard appears, click *Next*.
2. Insert the Promise FastTrak Driver diskette in the A: drive.
3. Under Install Hardware Device Drivers, select *Search for a suitable driver...* and click *Next*.
4. Under Locate Driver Files, uncheck *Floppy disk drives and CD-ROM drives*. Check *Specify a Location* and click *Next*.
5. Under Insert the manufacturer's installation disk, type **A:\win2000** and click *OK*.
6. Under Driver Files search Results, when *a:\Win2000 Promise Technology Inc. FastTrak S150 SX4/SX4000 series \fastsx.inf* should appear, click *Next*.
7. If a Digital Signature Notice appears, click *Yes*.
8. Under Completing the New Hardware Wizard, click *Finish*.
9. Click *Yes* to restart your PC.
10. Remove the Promise FastTrak Driver diskette.

**Note:** Check the readme file, included with the downloaded driver files, for instructions on installing the RAID Console.

## Confirm Installation

1. From the Windows Desktop, open the Control Panel from My Computer.
2. Click on the System icon.
3. Choose the Hardware tab, and then click the Device Manager button.
4. Click the + in front of SCSI controllers. *Win2000 Promise FastTrak S150 SX4/SX4000 Series* should appear.

## Red Hat Linux 8.0, 9.0

### Install Driver During New OS Installation

1. Start the RedHat Linux Installation by booting with the installation diskette or bootable CD ROM.
2. At the *Welcome to Red Hat Linux ...* installation screen, a prompt labeled *boot:* will appear at the bottom of the screen. Type **linux dd** and press Enter.
3. When the Installer asks, *Do you have a driver disk?* click **Yes**.
4. At the *Insert your driver disk and press OK to continue*, insert the driver diskette into the floppy drive and click **OK**. At the *Devices* dialog box, insert the FastTrak driver diskette in the floppy drive and click **OK**.
5. When the *Devices* dialog box appears, select **Add Device**.
6. When the Installer asks, *What kind of device would you like to add?*, select **SCSI**.
7. Scroll down to the *Promise FastTrak S150 SX4 ATA-RAID Controller* and click **OK**.
8. When the Installer displays *Promise FastTrak S150 SX4 ATA-RAID Controller* has been found, click **Done**.
9. Continue with the installation normally.

**Note:** Check the readme file, included with the downloaded driver files, for instructions on installing the RAID Console.

### Install Driver in an Existing System

1. Insert FastTrak Driver Diskette into the floppy drive.
2. Log in as *root*.
3. Type Run **mount -r /dev/fd0 /mnt/floppy**.
4. Run **cd /mnt/floppy; sh .install**.
5. When the *Installer* asks, *You are installing a driver on an existing OS. Is it true (y/n)?*, type **Y** and press Enter.
6. Run **cd; umount /mnt/floppy**.
7. Remove the FastTrak Driver Diskette and type **reboot** to restart the system.

**Note:** Check the readme file, included with the downloaded driver files, for instructions on installing the RAID Console.

## **SuSE Linux 8.1, 8.2**

### **Install Driver During New OS Installation: Single Processor**

1. Insert the install CD into CD-ROM drive.
2. When the boot: picture prompts for an installation option, add the following line to the input box: **acpi=oldboot**.
3. Press the left Alt key and insert the FastTrak driver diskette into the floppy drive.
4. Finish the installation normally.

**Note:** Check the readme file, included with the downloaded driver files, for instructions on installing the RAID Console.

### **Install Driver During New OS Installation: Multi-Processor**

1. Set the BIOS to boot from the CD-ROM.
2. Insert the install CD into CD-ROM drive.
3. When the boot: prompt appears on the bottom of the screen, type **acpi=oldboot** into the lower input box.
4. Press the left Alt key and insert the FastTrak driver diskette into the floppy drive.
5. Finish the installation normally.

**Note:** Check the readme file, included with the downloaded driver files, for instructions on installing the RAID Console.

### **Install Driver in an Existing System**

1. Insert the FastTrak driver diskette into the floppy drive.
2. Type the following commands:

```
# mount /dev/fd0 /media /floppy
# cd /media /floppy
# ./install
# insmod FastTrak
# umount /media /floppy
```
3. Remove the FastTrak driver diskette from the floppy drive.

**Note:** Check the readme file, included with the downloaded driver files, for instructions on installing the RAID Console.

## FreeBSD 4.x

### Install Driver During New OS Installation

1. Boot your computer from the FreeBSD install CD.
2. When the screen displays "Booting [kernel] in X seconds...", press any key except Enter to enter the OK prompt.
3. Insert the FastTrak driver diskette into your floppy drive.
4. Under the ok prompt, type the following commands:

```
set currdev=disk1
load sx.ko
set currdev=disk0s4a
boot
```
5. Remove the FastTrak driver diskette. Continue the installation process normally.
6. When the installation is complete, do NOT exit. Instead, press Alt+F4 to switch to another screen.
7. Again insert the FastTrak driver diskette into your floppy drive and type the following commands:

```
mount /dev/fd0 /mnt
/mnt/install
umount /mnt
```

and wait the commands to finish.
8. Remove the FastTrak driver diskette and press Alt+F1.
9. Exit the installation.

**Note:** Check the readme file, included with the downloaded driver files, for instructions on installing the RAID Console.

### Specify SX4030 or SX4060 as a SCSI Device

1. Copy the sx.ko file to the /modules directory.
2. Type the following commands:

```
kldload sx.ko
camcontrol rescan all
```

The RAID targets on the FastTrak card should be detected as SCSI devices.

## Promise RAID Utility

To install the utility, type the following commands:

```
mount /dev/fd0 /mnt  
/mnt/install util  
umount /mnt
```

To use the utility, type the following commands:

```
cd /usr/local/promise  
./sxcsclapp
```



# Chapter 5: Disk Array Concepts

- About FastTrak, below
  - Disk Array Terms, below
  - About RAID Levels, page 43
- 

## **About FastTrak**

FastTrak SX4030, SX4060 and S150 SX4-M are high performance RAID Controller cards that feature concurrent data channel operation and onboard BIOS. The channels on the FastTrak card support concurrent operation that allows for overlapped I/O under multi-tasking operating systems and sharing the workload between multiple drives.

## **About Adapter BIOS**

The FastTrak card contains a BIOS code that extends the standard disk service routine provided through Int13. The BIOS is bootable for DOS and other operating systems that rely on the system BIOS for drive operation. When the FastTrak BIOS appears during bootup, press Ctrl-F to enter the FastBuild setup to select from menu settings.

## **Reserve Sector**

Array configuration data about the drive member and other members in the disk array are saved on a special location on the disk drives called the *reserve sector*. If any member of the array becomes corrupt or lost, the redundant configuration data on the other members can be used for rebuilds.

Disk array members do not have a memory of their drive positions. This allows drives to be placed on different FastTrak connectors or cards within the system without reconfiguring or rebuilding.

## **Disk Array Terms**

### **Description**

A disk array is formed from a group of two or more disk drives that appear to the system as a single drive. The advantage of an array is to provide better throughput performance and/or data fault tolerance.

Better performance is accomplished by sharing the workload among multiple physical drives.

Fault tolerance is achieved through data redundancy operation where if one (or more) drive fails or has a sector failure, a mirrored copy of the data can be found on another drive(s).

For optimal results, select identical Serial ATA drives (S150 SX4-M) or Ultra ATA drives (SX4030 / SX4060) to install in disk arrays. The matched performance of the drives allows the array to function better as a single drive.

## Member

The individual disk drives in an array are called members. Each member of a specific disk array has coded in its reserved sector configuration information that identifies the drive as a member. All disk members in a formed disk array are recognized as a single physical drive to the system.

## Types

For most installations, the FastBuild setup Auto Setup (1) option will configure your system. There are four disk array types in three categories that can be installed on the FastTrak SX4030, SX4060 or S150 SX4-M card:

- Performance – RAID 0
- Fault Tolerance – RAID 1
- Performance plus Fault Tolerance – RAID 0+1, RAID 5

FastBuild also supports *Just a Bunch of Disks* (JBOD) technology. JBOD allows you to add up to four disk drives to your computer for expanded storage capacity. However, unlike RAID, JBOD drives function individually, thus there is no performance increase nor any fault tolerance..

RAID Level	Performance	Fault Tolerance	Capacity	No. of Drives
RAID 0 (Stripe)	Highest	No	No. Drives x Smallest Drive	2 to 4
RAID 1 (Mirror)	Normal	Yes	Smallest Drive	2
RAID 0+1 (Stripe/Mirror)	High	Yes	2X Smallest Drive	4
RAID 5 (Distributed Parity)	High	Yes	Smallest Drive x No. Drives -1	3 or 4
JBOD (Single Drive)	Normal	No	Sum of all Drives	1 to 4

## About RAID Levels

### RAID 0 (Stripe)

Reads and writes sectors of data interleaved between multiple drives. When any disk member fails, it affects the entire array. Performance is better than a single drive since the workload is balanced between the array members. This array type is for high performance systems. Identical drives are recommended for performance as well as data storage efficiency. The disk array data capacity is equal to the number of drive members times the smallest member capacity. For example, one 100 GB and three 120 GB drives will form a 400 GB (4 x 100 GB) disk array.



**Figure 1. RAID 0 writes data to both drives at the same time**

**Stripe Size** – A value can be set from 16KB to 256KB sector size. The size can directly affect performance. In the FastBuild BIOS, the default is 64KB.

## RAID 1 (Mirror)

Writes duplicate data on to a pair of drives while reads are performed in parallel. RAID 1 is fault tolerant because each drive of a mirrored pair is installed on separate controller channels. If one of the mirrored drives suffers a mechanical failure (for example, spindle failure) or does not respond, the remaining drive will continue to function. This is called Fault Tolerance. If one drive has a physical sector error, the mirrored drive will continue to function.

On the next reboot, the FastBuild Utility will display an error in the array and recommend replacing the failed drive. Users may choose to continue using their PC, however Promise recommends replacing the failed drive as soon as possible. Due to redundancy, the drive capacity of the array is half the total drive capacity. For example, two 100 GB drives that have a combined capacity of 200 GB would have 100 GB of usable storage. With drives of different capacities, there may be unused capacity on the larger drive.

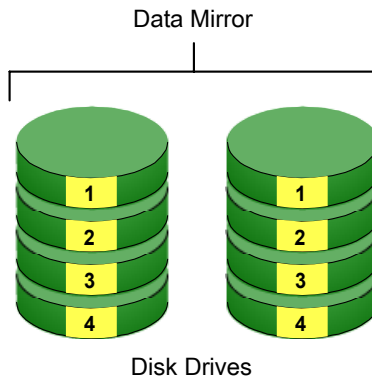

**Figure 2. RAID 1 copies the data from one drive to the other.**

**Spare Drive** – Under a RAID 1 setup, an extra hot spare drive. You can attach a third drive to the FastTrak SX4030, SX4060 or S150 SX4-M card without assigning it to the array. Such a drive will be activated to replace a failed drive that is part of a mirrored array. A rebuild takes place automatically in the background to mirror the good drive data on to the spare. At a later time, the system can be powered off and the failed drive can be physically removed and replaced. Spare drives must be the same or larger capacity than the smallest array member.

## RAID 0+1 (Stripe/Mirror)

A combination of RAID 0 and RAID 1 arrays. It can increase performance by reading and writing data in parallel while protecting data with duplication. A minimum of four drives are required.

With a four-drive disk array, two pairs of drives are striped. Each pair mirrors the data on the other pair of striped drives. The data capacity is similar to a standard Mirroring array with half of total capacity dedicated for redundancy.

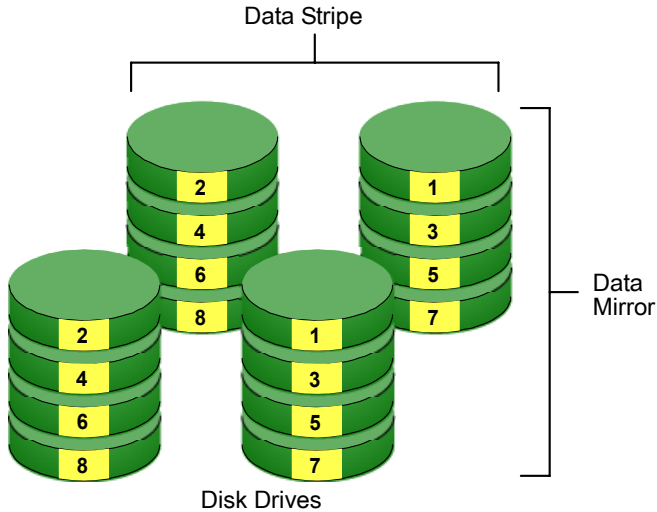

**Figure 3. RAID 0+1 starts with a two-drive Striped array copies it onto two additional drives to make a Mirror**

## About Dual Data Redundancy

One unique (though rarely occurring) feature of RAID 0+1 is dual fault tolerance. In some cases, two drives can fail simultaneously and still maintain the integrity of data. There are six combinations in which two drives can fail. The FastTrak SX4030, SX4060 or S150 SX4-M card protects the data array in four of those cases. Assume the drives are configured as follows:

- CH indicates channels on the FastTrak Controller card.
- A/B indicates which striped pair the drive belongs to.
- 1/2 indicates which part of stripe data.

CH1	CH2	CH3	CH4
Drive A1	Drive A2	Drive B1	Drive B2

Under RAID 0+1, the array maintains data integrity if any 1, 2 combination survives.

Event	Failed Drives	Array Status	Why?
1	A1/A2	Functional	B1/B2 retain array integrity
2	B1/B2	Functional	A1/A2 retain array integrity
3	A1/B2	Functional	B1/A2 retain array integrity
4	B1/A2	Functional	A1/B2 retain array integrity
5	A1/B1	Offline	B2/A2 contain only half the array data
6	B2/A2	Offline	A1/B1 contain only half the array data

## RAID 5 (Block and Parity Striping)

RAID 5 calculates parity in order to achieve redundancy rather than writing a second copy of the data, like RAID 1. Parity is distributed across the physical drives along with the data blocks. In each case, the parity data is stored on a different disk than its corresponding data block. RAID 5 makes efficient use of hard drives and is the most versatile RAID Level. It works well for file, database, application and web servers.

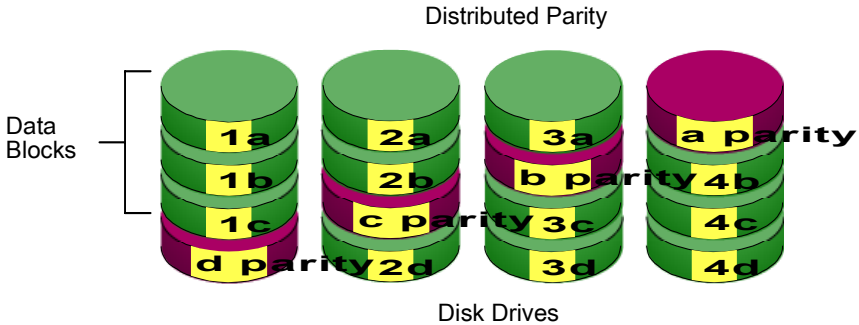

**Figure 4. RAID 5 Stripes all Drives with Data and Parity Information.**

The capacity of a RAID 5 array is the smallest drive size multiplied by the total number of drives, less minus one. Hence, a RAID 5 array with four 100 GB hard drives will have a capacity of 300 GB. An array with two 120 GB hard drives and one 100 GB hard drive will have a capacity of 200 GB.

## JBOD – Single Drive

An alternative to RAID, JBOD capacity is equal to the sum of all drives in the group, even if the drives are of different sizes.

JBOD appears in the User Interface as one or more individual drives.

There are no performance or fault-tolerance features. When one disk fails, all data on that disk is lost. The other disks are unaffected.



Disk Drive

***Figure 5. JBOD manages drives Individually, unlike RAID.***



# Chapter 6: Troubleshooting & Tips

- Motherboard Issues, below
  - System CMOS Issues, page 50
  - Drive-Related Errors, page 50
  - Operating System-Related Issues, page 53
  - Performance Tips, page 54
- 

This section is used to assist with troubleshooting conflicts and FastTrak SX4030, SX4060 or S150 SX4-M installation problems. Also refer to the README.TXT file on the FastTrak driver and utility diskette for more recent information as well as the PromiseOnline services listed in Chapter 7.

The section is divided into the following categories: Motherboard Issues, System CMOS Issues, Drive Errors, Operating System Errors, and Audio/Video Editing Tips.

## ***Motherboard Issues***

### **Freeing additional IRQ resources**

Since the Promise card supports PCI Interrupt sharing, it is possible to use IRQs already assigned to another PCI card. Interrupt Sharing is not supported with onboard IDE controllers. If the onboard IDE controller(s) are not used, you may disable the controllers to free IRQ 14 and/or 15.

### **Configuring PCI IRQ resources**

Setting the IRQ for a particular PCI slot will be different depending on the motherboard BIOS. This setting is usually made in the PCI Configuration and/or Plug and Play (PnP) section of the motherboard BIOS setup. There are three common methods that motherboard BIOS's handle assignment of IRQs to PCI slots:

- Specifically assigning an IRQ to a particular slot - You can tell the motherboard to use IRQ 10 for PCI slot 1, IRQ 11 for PCI slot 2, etc.
- Listing which IRQs are available to be assigned to the PCI slots - This BIOS has an option where you specify 1st Available IRQ, 2nd Available IRQ, etc. The BIOS then scans the PCI slots for PCI cards and assigns these IRQs in the order that it finds the PCI cards.
- Excluding an IRQ from being used by a PCI slot - If you have an ISA card that is using an IRQ, change the setting for this particular IRQ from Available to Used by ISA card so that the motherboard will not assign this IRQ to a PCI slot.

Consult your motherboard manual for information that is specific to your motherboard.

---

### **System locks up during boot up or when Windows starts**

There may be a possible IRQ conflict with an ISA card. Identify what IRQs are used by ISA cards, enter the Motherboard PCI Setup, and reserve the IRQ for use with ISA. PCI slots cannot share IRQs with ISA cards.

Miscellaneous problems such as:

- FastTrak BIOS does not appear during boot
- FastTrak driver does not load
- Slow data transfer rates

Move the FastTrak card to a different PCI slot.

### **Intermittent data problems**

Overclocking the PCI bus may cause the system to hang or data corruption. If you experience either of these problems and you are overclocking the PCI bus, set the PCI bus back to its normal setting to see if this is causing the errors.

## ***System CMOS Issues***

### **Set Motherboard CMOS Boot sequence to boot to the FastTrak card**

On some Motherboard BIOS, it is necessary to set the Boot sequence to SCSI, A:, C: since the Promise card is identified as a SCSI card.

### **Motherboard CMOS displays C: or D: drive failure during startup**

See the Drive-Related Errors section.

### **Using an Onboard IDE Card with FastTrak card**

If an onboard IDE controller is installed with hard disks, enable support in the Motherboard Standard CMOS Setup for the drives. Note that the onboard IDE hard drives will then be the bootable hard disk unless the system BIOS has a boot sequence setting with the option to specify booting to a different device.

## ***Drive-Related Errors***

### **Critical Array Status Error Reported during Boot**

If a critical status error message appears on the FastTrak BIOS startup screen for a mirrored array (see below), there is a drive in the array that has failed or is not responding. The FastTrak controller will identify the failed drive by channel number. The mirrored array has lost its fault tolerance, but will still perform normal drive reads and writes.

Powering the system off and on once to reset the drive. Also confirm that cables are properly attached and the drive is receiving power. If the drive still appears to have failed, refer to the Rebuilding an Array option in the Promise Array Management (PAM) utility as detailed in the PAM User Manual.

### **Drive cannot be formed into an array**

Drives must support Serial ATA and be free of media defects to be added into an array. Promise recommends using new identical drives for each array. Re-secure data and power cabling while checking for proper alignment. Typically, Pin 1 of the drive is closest to the power connector.

### **System CMOS displays C: or D: drive failure during Startup**

Do not reference C: or D: in the Motherboard Standard CMOS for drives attached to the FastTrak controller. Only enter drive information in the Motherboard CMOS for drives attached to the onboard IDE controller.

### **FDISK reports a much lower drive capacity if a single physical drive or a striped array exceeds 64GB (Windows 2000)**

Due to a limitation with FDISK, the utility reports only the storage capacity that exceeds 64GB. This is a cosmetic, not actual, limitation. Simply create a single DOS drive partition, reboot, and then format the partition. The Format command will recognize the total capacity of the partition accurately. Windows will now recognize the total capacity of your array.

### **Unable to Partition or Format Array**

There are two possible causes:

- The FastTrak Controller is the bootable device but the array is not set to be bootable.
- The Reserve Sector of one of the drives has become corrupt or bad.

If the FastTrak Controller is the bootable device, make sure that the array is set to be bootable:

1. During boot-up, press Ctrl-F to enter the FastBuild BIOS utility.
2. Choose option 2, Define Array.
3. Press the Up and Down Arrow keys to highlight the array that you want to boot from.
4. Press the Spacebar to select.

An \* asterisk will appear next to the array number indicating it as bootable. The system will now recognize this array as the first array seen. The system will then use this bootable array as the (fixed) boot C: drive.

The Reserve Sector of one of the drives has become corrupt or bad. Removing the Reserve Sector will remedy any issue related directly to a Bad Reserve Sector.



### Warning

---

Before removing the Reserve Sector of the drive(s), backup any existing data. Removal of the reserve sector of any drive permanently deletes all existing data on the hard drive.

---

For RAID 1 arrays, remove the Reserve Sector from the mirrored drive first (this will appear during Step 3 below) then rebuild the mirrored array. Remove the Sector on the Master Drive only as a last resort.

For RAID 0 and RAID 5 arrays, removing the Reserve Sector from any of the drives will destroy the arrayed data.

For JBOD, removing the Reserve Sector from any of the drives will destroy the data on that drive.

To remove the Reserve Sector, follow these steps:

1. During boot up, press Ctrl-F to enter the FastBuild BIOS utility.
2. Choose option 1, View Drive Assignments.
3. Press arrow keys to highlight the drive where you wish to remove the reserve sector.
4. Press Alt-F1. The following message will appear: Press Ctrl-Y to delete the data in the disk or press any key to abort. The highlighted drive will start blinking on the screen.
5. Press Ctrl-TabY. The following message will appear: The Reserved Sector was wiped! System will reboot when you exit this menu. Press any key to continue. A message will appear that says the reserved sector (which is where array information is kept) on the disk will be wiped. 1. Press Y to confirm.
6. Take the appropriate action:
  - For RAID 1 and RAID 5 arrays, repeat this process for each member of the particular array that is having a problem. When you are finished, press the Esc key twice to reboot
  - For RAID 1 arrays, hit the Esc key twice to reboot
7. After rebooting, use FastBuild to re-create the array.
  - For striped arrays, use FDISK and FORMAT after setting up the array
  - For mirrored arrays, rebuild the mirrored array

### **Array Constantly Goes Into Critical or Offline Mode During Reboot**

See Unable to Partition or Format array, above.

### **Cannot Rebuild Mirrored (RAID 1) Array**

See Unable to Partition or Format array, above.

### **Fatal Errors or Data Corruption Are Constantly Reported When Reading or Writing to Drive Array**

See Unable to Partition or Format array, above.

## ***Operating System-Related Issues***

### **The Operating System no longer boots after creating a Mirrored Array using your existing boot drive using Windows 2000/XP/2003 Server**

This is due to Drive Geometry issues. You can verify this if you move the original drive back to the onboard controller and it boots successfully. Each controller can view a drive differently. This can be an issue for a new controller that loads the original Master Boot Record (MBR) and then has a problem translating it or the Operating System boot record.

For Windows 2000, XP and 2003 Server, Promise recommends a clean install of the Operating System. This action restores the MBR and OS boot record. This requires repartitioning and formatting the drive.

### **Promise Windows driver does not appear in Device Manager**

Windows may already be listing the controller under Other Devices instead of the Hard disk controllers section. In Device Manager under Other Devices to see if it lists a PCI Card or RAID Controller. If so, highlight this listing and click on the Properties button then click on the Driver tab.

Depending on your version of Windows, choose either Change Driver or Update Driver. Follow the on-screen prompts to complete installation of the driver. If Windows asks if you want to test if the device can be removed safely, click on CANCEL. Reboot the system to complete installation of the driver.

### **“Inaccessible Boot Device” Message Appears During Floppiless Installation of Windows**

You did not press the F6 key at the appropriate time. Reboot the system, and press the F6 key when the message *Press F6 if you need to install third party SCSI or RAID driver?* appears.

### **“No Hard Drives Found” Message Appears During CD-ROM Installation of Windows**

You did not press the F6 key at the appropriate time. Reboot the system, and press the F6 key when the message *Press F6 if you need to install third party SCSI or RAID driver* appears.

## ***Performance Tips***

Here are some tips that may optimize performance in a RAID 0 striped array. If you are using an audio/video-editing card, we also recommend reviewing your card's documentation for additional information.

### **Use a FastTrak array as D: or other non-bootable drive in a Striped Array**

For Audio/Video editing, keep the original system boot drive on the standard IDE controller as C: drive. Partitioning software such as FDISK will see the array as one physical drive, D: or later. This will prevent file fragmentation and provide better accessibility to the array.

### **Re-Configure PCI Latency Setting**

The PCI Latency setting appears in some Motherboard BIOS. The setting governs how much time is allocated to service each PCI slot. Promise recommends a value of 64. An optimal value will vary from system to system.

# Chapter 7: Support

- Frequently Asked Questions, below
  - Contact Technical Support, page 60
  - Limited Warranty, page 62
  - Return Product for Repair, page 63
- 

## ***Frequently Asked Questions***

This section lists frequently asked questions involving pre-installation, drive issues, installation, and post-installation.

### **Pre-Installation (Speed, Device Types, Capacity, Cabling)**

#### **What kind of hard drives can I use for a FastTrak S150 SX4-M array?**

You can use any Serial ATA hard drive(s) to create arrays on the FastTrak S150 SX4-M. Use matching drives for multiple-drive arrays to maximize capacity usage as well as performance.

#### **What kind of hard drives can I use for a FastTrak SX4030/SX4060 array?**

You can use any Ultra ATA/100, or Ultra ATA/33/ hard drive(s) to create arrays on the FastTrak SX4030/SX4060. Use matching drives for multiple-drive arrays to maximize capacity usage as well as performance.

You can use Ultra ATA/133 drives but their data throughput will be at the Ultra ATA/100 rate.

#### **Will ACPI work with HDDs on the FastTrak SX4030, SX4060 and S150 SX4-M?**

Yes. The FastTrak Controller supports ACPI S1, S3 and S4 standby modes.

#### **Can I use ATAPI devices on the FastTrak SX4030, SX4060 and S150 SX4-M?**

No. This FastTrak Controller does not support ATAPI devices.

#### **Will the FastTrak SX4030, SX4060 and S150 SX4-M work with 66MHz PCI bus speed?**

FastTrak SX4060 and S150 SX4-M work with a 66MHz or 33MHz PCI bus. FastTrak SX4030 works with a 33MHz PCI bus only.

### **How can I change the resources that the FastTrak uses?**

The FastTrak SX4030, SX4060 and S150 SX4-M are fully PnP. This means all the resources that it uses are given to it by the PnP BIOS on the motherboard.

The FastTrak Controller supports IRQ sharing, but this feature only works when ALL the concerned devices support it. If your motherboard allows you to control the assignment of these resources, you may be able to remedy the problem by:

- Changing the IRQ assignments to the PCI slots in the motherboard BIOS during boot up.
- Reset the configuration data in your CMOS. This is usually an option in the PnP section of your CMOS.
- Otherwise, switch the FastTrak Controller card to a different PCI slot.

### **How do the FastTrak SX4030, SX4060 and S150 SX4-M RAID Controllers provide storage and data protection with their arrays?**

FastTrak SX4030, SX4060 and S150 SX4-M implement five RAID levels as follows:

#### **RAID 0 (Stripe)**

For capacity – The FastTrak RAID 0 array will be as big as the smallest HDD in the array times however many HDDs are in the array. Any larger HDDs will simply be truncated. The truncated space on the bigger HDDs will then be unusable.

For sustained data transfers – Using a FastTrak Controller, a RAID 0 array consisting of two HDDs will transfer at about twice the speed of the slowest HDD in the array. A RAID 0 array consisting of four HDDs will transfer at about three times the speed of the slowest HDD in the array.

#### **RAID 1 (Mirror)**

For capacity – The FastTrak RAID 1 array will be as big as the smallest HDD in the array. The larger HDD will simply be truncated. The truncated space on the bigger HDD will then be unusable.

For sustained data transfers – The FastTrak RAID 1 array will write data at the rate of the slowest HDD in the array. The FastTrak array will read data at twice the rate of the slowest HDD in the array.

#### **RAID 0+1 (Stripe/Mirror)**

For capacity – The FastTrak RAID 0+1 array will be one-half the size of the smallest HDD in the array. The larger HDDs will be truncated. The truncated space on the bigger HDDs will then be unusable.



For sustained data transfers – The FastTrak RAID 0+1 array consisting of four HDDs will transfer at about twice the speed of the slowest HDD in the array.

### **RAID 5 (Block and Parity Striping)**

For capacity – The FastTrak RAID 5 array is the smallest drive size multiplied by the number of drives, less one. The larger HDDs will be truncated. The truncated space on the bigger HDDs will then be unusable.

For sustained data transfers – The FastTrak RAID 5 array will write data at moderate speed but will read data very quickly. The fact that you can use 3 or 4 drives and the effect of parity calculations means defining speed in terms of a single HDD is difficult and imprecise.

### **JBOD (Just a Bunch of Disks)**

Technically, JBOD is not a RAID level but a collection of single disk drives. The FastTrak SX4030, SX4060 and S150 SX4-M support up to four such drives.

## **Drive Issues**

### **Can I add a drive to a FastTrak SX4030, SX4060 and S150 SX4-M array via hot-swap and dynamically adjust the array size/configuration?**

No. The FastTrak Controller does not support dynamically adjustable RAID size/configurations.

### **Do the HDDs on the FastTrak SX4030, SX4060 and S150 SX4-M have to be the same size?**

The HDDs that you use with the FastTrak SX4030, SX4060 and S150 SX4-M do not have to be the same size. If the sizes differ, the FastTrak Controller will truncate the bigger HDD so the drives match. The resulting difference in HDD space is unusable, so avoid using HDDs of significantly different capacities.

### **I already have an array on an older FastTrak controller. Can I move that array to my new FastTrak SX4030, SX4060 and S150 SX4-M controller?**

Yes. All FastTrak controllers read the arrays the same way and can be moved from one controller to another.

**Can I take a drive used in a FastTrak SX4030, SX4060 and S150 SX4-M array and access it directly with a different controller, such as the one integrated on the motherboard?**

Yes, but only under certain configurations. First, the other controller must address the drives as LBA, not CHS.

Second, only the following configurations allow the drive(s) to be accessed individually on another controller:

- Single-drive RAID 0 (stripe)
- One drive from a RAID 1 (mirror) array
- JBOD

Other array configurations will not work for this purpose.

**If I have a problem with one of the drives on the FastTrak SX4030, SX4060 and S150 SX4-M, how can I low-level format it to correct the problem?**

Do NOT do this! Low-level formatting hard disk drives is not only unnecessary but it generally does not correct problems commonly experienced during use.

Errors such as bad sectors or ECC/CRC failure are best remedied by completely replacing the drive. For this reason, do NOT low-level format the drives attached to the FastTrak Controller.

**Do I have to install disk management software on my array in order to access the full storage capacity of drives?**

No! Disk management software will only complicate things. The array should be fully addressable by your OS as it is. Remember that some operating systems have varying limits on the sizes of partitions and logical drives that can be defined. Consult your OS documentation about partitioning larger drives.

**What system BIOS setup settings do I use for the drives on the FastTrak SX4030, SX4060 and S150 SX4-M controller?**

None. The drives on the FastTrak Controller are supported by the FastTrak BIOS and/or OS drivers, not by your system BIOS.

**How do I partition/format my FastTrak SX4030, SX4060 and S150 SX4-M RAID array?**

The FastTrak Controller represents the array as a single HDD to your system. Therefore, anything that you can do to a single HDD you can do to a FastTrak array.

For example, you should use the FDISK and FORMAT utilities to partition and format the array. You can partition the array as you see fit. You can format the array with any file system you wish.

**Installation Issues (Capacity, Booting)****Why are some drives recognized by the FastTrak SX4030, SX4060 and S150 SX4-M Array Setup utilities with only partial capacity?**

Some hard drives ship with a jumper that reduces the addressable capacity of the drive to prevent problems with older systems that don't support larger drives. Consult your hard drive documentation to set the jumper so that you can use the full capacity of the drive.

**How can I change the system boot sequence in order to boot from the FastTrak SX4030, SX4060 and S150 SX4-M array?**

The boot sequence is controlled by the system BIOS. As far as the system BIOS is concerned, the FastTrak Controller and defined arrays are categorized as a SCSI device. This allows you to set the boot sequence in your BIOS setup utility to boot from SCSI first, rather than IDE.

If there are multiple SCSI add-in controllers in the system, then the boot sequence among them will be determined exclusively by their PCI slot priority. PCI slot #1 will be first, slot #2 second, etc. Put the FastTrak Controller in the PCI slot where it will be accessed ahead of other SCSI controllers if you want to boot from the array.

**How can I change the boot sequence between a PCI SCSI card and the FastTrak SX4030, SX4060 and S150 SX4-M RAID array?**

Since all PCI devices are PnP, it is difficult to determine which device is addressed first. Some newer motherboard BIOSes have advanced options that identify devices and allow you to select which device will be assigned resources first. Otherwise you may have to physically switch the device cards on the PCI slots so that the boot device is in the highest priority slot number (see previous question).

## Post-Installation

### Why can't I see the drives on the FastTrak SX4030, SX4060 and S150 SX4-M under FDISK?

You have not created an array yet. If no array has been created, the system will not recognize drive(s) attached to the FastTrak Controller.

### How can I obtain the latest FastTrak drivers?

Download the latest drivers from the Promise Technology website at [www.promise.com](http://www.promise.com).

## Contact Technical Support

Promise Technical Support provides several support options for Promise users to access information and updates. We encourage you to use one of our electronic services, which provide product information updates for the most efficient service and support.

If you decide to contact us, please have the following information available:

- Product model and serial number
- BIOS and driver version numbers
- A description of the problem / situation
- System configuration information, including: motherboard and CPU type, hard drive model(s), ATA/ATAPI drives & devices, and other controllers.

## Technical Support Services

---

Promise Online™ Web Site	<a href="http://www.promise.com">http://www.promise.com</a> (technical documents, drivers, utilities, etc.)
--------------------------	--

---

### North & South America

---

E-mail Support	<a href="mailto:support@promise.com">support@promise.com</a>
Fax Technical Support	(408) 228-6401 Attention: Technical Support
Phone Technical Support	(408) 228-6402 7:30-5:30pm M-F Pacific Standard Time
If you wish to write us for support:	Promise Technology, Inc. Attn: Technical Support 1745 McCandless Drive Milpitas, CA 95035, USA

---

## Europe, Africa, Middle East

E-mail Support	support@promise.nl
Fax Technical Support	+31 (0) 40 256 9463 Attention: Technical Support
Phone Technical Support	+31 (0) 40 235 2600 8:30-5:00pm The Netherlands Time
If you wish to write us for support:	Promise Technology Europe B.V. Attn: Technical Support Luchthavenweg 81-125 5657 EA Eindhoven, The Netherlands

## Pacific Rim

E-mail Support	support@promise.com.tw
Fax Technical Support	+886 3 564 53 13 Attention: Technical Support
Phone Technical Support	+886 3 578 23 95 (ext. 8873) 9:00-5:30pm Taiwan Time
If you wish to write us for support:	Promise Technology, Inc. Attn: Technical Support 2F, No. 30, Industry E. Rd. IX Science-based Industrial Park Hsinchu, Taiwan, R.O.C.

## China

E-mail Support	support-china@promise.com
Fax Technical Support	+86 10 6872 3940 Attention: Technical Support
Phone Technical Support	+86 10 6872 3941 9:00-6:00pm China Time
If you wish to write us for support:	Promise Technology China Attn: Technical Support Room 3213, No. 11 South Zhong Guan Cun Street Hai Dian District, Beijing 100081 P.R. China

## **Limited Warranty**

Promise Technology, Inc. (“Promise”) warrants that for three (3) years from the time of the delivery of the product to the original end user:

- a) the product will conform to Promise’s specifications;
- b) the product will be free from defects in material and workmanship under normal use and service.

This warranty:

- a) applies only to products which are new and in cartons on the date of purchase;
- b) is not transferable;
- c) is valid only when accompanied by a copy of the original purchase invoice.
- d) Is not valid on spare parts, fans, and power supplies

This warranty shall not apply to defects resulting from:

- a) improper or inadequate maintenance, or unauthorized modification(s), performed by the end user;
- b) operation outside the environmental specifications for the product;
- c) accident, misuse, negligence, misapplication, abuse, natural or personal disaster, or maintenance by anyone other than a Promise or a Promise-authorized service center.

## **Disclaimer of other warranties**

This warranty covers only parts and labor, and excludes coverage on software items as expressly set above.

Except as expressly set forth above, Promise **DISCLAIMS** any warranties, expressed or implied, by statute or otherwise, regarding the product, including, without limitation, any warranties for fitness for any purpose, quality, merchantability, non-infringement, or otherwise. Promise makes no warranty or representation concerning the suitability of any product for use with any other item. You assume full responsibility for selecting products and for ensuring that the products selected are compatible and appropriate for use with other goods with which they will be used.

Promise **DOES NOT WARRANT** that any product is free from errors or that it will interface without problems with your computer system. It is your responsibility to back up or otherwise save important data before installing any product and continue to back up your important data regularly.

No other document, statement or representation may be relied on to vary the terms of this limited warranty.

Promise's sole responsibility with respect to any product is to do one of the following:

- a) replace the product with a conforming unit of the same or superior product;
- b) repair the product.

Promise shall not be liable for the cost of procuring substitute goods, services, lost profits, unrealized savings, equipment damage, costs of recovering, reprogramming, or reproducing of programs or data stored in or used with the products, or for any other general, special, consequential, indirect, incidental, or punitive damages, whether in contract, tort, or otherwise, notwithstanding the failure of the essential purpose of the foregoing remedy and regardless of whether Promise has been advised of the possibility of such damages. Promise is not an insurer. If you desire insurance against such damage, you must obtain insurance from another party.

Some states do not allow the exclusion or limitation of incidental or consequential damages for consumer products, so the above limitation may not apply to you.

This warranty gives specific legal rights, and you may also have other rights that vary from state to state. This limited warranty is governed by the State of California.

## **Your Responsibilities**

You are responsible for determining whether the product is appropriate for your use and will interface with your equipment without malfunction or damage. You are also responsible for backing up your data before installing any product and for regularly backing up your data after installing the product. Promise is not liable for any damage to equipment or data loss resulting from the use of any product.

## ***Return Product For Repair***

If you suspect a product is not working properly, or if you have any questions about your product, contact our Technical Support Staff through one of our Technical Services, making sure to provide the following information:

- Product model and serial number (required)
- Return shipping address
- Daytime phone number
- Description of the problem
- Copy of the original purchase invoice

The technician will assist you in determining whether the product requires repair. If the product needs repair, the Technical Support Department will issue an RMA (Return Merchandise Authorization) number.

Return ONLY the specific product covered by the warranty (do not ship cables, manuals, diskettes, etc.), with a copy of your proof of purchase to:

USA and Canada:	Promise Technology, Inc. Customer Service Dept. Attn.: RMA # _____ 1745 McCandless Drive Milpitas, CA 95035
Other Countries:	Return the product to your dealer or retailer.  Contact them for instructions before shipping the product.

You must follow the packaging guidelines for returning products:

- Use the original shipping carton and packaging
- Include a summary of the product's problem(s)
- Write an attention line on the box with the RMA number
- Include a copy of proof of purchase

You are responsible for the cost of insurance and shipment of the product to Promise. Note that damage incurred due to improper transport or packaging is not covered under the Limited Warranty.

When repairing returned product(s), Promise may replace defective parts with new or reconditioned parts, or replace the entire unit with a new or reconditioned unit. In the event of a replacement, the replacement unit will be under warranty for the remainder of the original warranty term from purchase date, or 30 days, whichever is longer.

Promise will pay for standard return shipping charges only. You will be required to pay for any additional shipping options (such as express shipping).



# Appendix A: Memory Upgrade Test

A Dual Inline Memory Module (DIMM) for Synchronous Dynamic Random Access Memory (SDRAM) providing 64 MB of cache memory is included with the FastTrak RAID Controller card. Promise has already tested and verified the DIMM included with the FastTrak card.

You can upgrade to a SDRAM DIMM of up to 256 MB for additional capacity and performance. Promise Technology does not sell larger DIMMs for FastTrak cards. But Promise does provide a test to ensure that your DIMM will function reliably in your FastTrak card.

Testing is necessary because an incompatible DIMM can appear to work properly, only to later experience unexpected errors that can result in data loss or controller malfunction.



## Warning

---

The electronic components on the FastTrak RAID Controller card are sensitive to damage from Electro-Static Discharge (ESD). Observe appropriate precautions at all times when handling the FastTrak card or its subassemblies.

---

## ***DIMM Selection***

Promise maintains a list of DIMMs that are known to work well with FastTrak. Use this list as a guide when buying your DIMM. Go to: [www.promise.com/support/](http://www.promise.com/support/) to view or download the list.

## ***DIMM Testing***

Promise recommends testing for all DIMMs being used in a FastTrak controller, including those from its currently approved list. Follow this procedure to verify your DIMM's compatibility with your FastTrak RAID Controller card.

1. Prepare a DOS Boot diskette.
2. Copy the Promise Test Utility files to a second diskette.
3. Install your SDRAM DIMM into the Cache Memory socket of the FastTrak card.
4. Plug in FastTrak card into a PCI slot on a desktop PC or server.
5. Boot the PC with the DOS Boot diskette.
6. Remove the DOS Boot diskette and insert the diskette with the Promise Test Utility files.

7. At the DOS prompt, type memtest and press Enter. The test begins.
  - If the DIMM is OK, the program will show a PASS message similar to the one below:

```
Promise Memory Test Utility V1.3 01/24/2004 18:07:50
Controller Type . . . . . : FastTrak 4060
Memory Speed. . . . . : 100MHz
Memory Size . . . . . : 128MB
Memory Type. . . . . : Non-ECC
Memory Test Result ( HOST ) . . . : PASS
Memory Test Result ( HDMA ) . . . : PASS
Memory Test Result ( XOR ) . . . . : PASS
```

The PASS message means you can use the DIMM that is currently installed.

- If there is any error, the program will stop and return to DOS and show error message. Do not use the DIMM.
- If the program halts for more than 20 seconds, there may be an error. Check the FastTrak card, DIMM, and your system BIOS. Then run the test again.