

# **Intel® Server Chassis SC5650**

## ***Technical Product Specification***

*Intel order number E39531-004*

**Revision 1.2**

**April, 2010**

**Enterprise Platforms and Services Division - Marketing**

---

## **Revision History**

Date	Revision Number	Modifications
January, 2009	1.0	Initial release.
May, 2009	1.1	Added SC5650UP sku information.
April, 2010	1.2	Removed CCC and CNCA.

## **Disclaimers**

Information in this document is provided in connection with Intel® products. No license, express or implied, by estoppel or otherwise, to any intellectual property rights is granted by this document. Except as provided in Intel's Terms and Conditions of Sale for such products, Intel assumes no liability whatsoever, and Intel disclaims any express or implied warranty, relating to sale and/or use of Intel products including liability or warranties relating to fitness for a particular purpose, merchantability, or infringement of any patent, copyright or other intellectual property right. Intel products are not intended for use in medical, life saving, or life sustaining applications. Intel may make changes to specifications and product descriptions at any time, without notice.

Designers must not rely on the absence or characteristics of any features or instructions marked "reserved" or "undefined." Intel reserves these for future definition and shall have no responsibility whatsoever for conflicts or incompatibilities arising from future changes to them.

This document contains information on products in the design phase of development. Do not finalize a design with this information. Revised information will be published when the product is available. Verify with your local sales office that you have the latest datasheet before finalizing a design.

The Intel® Server Chassis SC5650 may contain design defects or errors known as errata which may cause the product to deviate from published specifications. Current characterized errata are available on request.

Intel Corporation server baseboards contain a number of high-density VLSI and power delivery components that need adequate airflow to cool. Intel's own chassis are designed and tested to meet the intended thermal requirements of these components when the fully integrated system is used together. It is the responsibility of the system integrator that chooses not to use Intel developed server building blocks to consult vendor datasheets and operating parameters to determine the amount of air flow required for their specific application and environmental conditions. Intel Corporation can not be held responsible if components fail or the server board does not operate correctly when used outside any of their published operating or non-operating limits.

Intel, Pentium, Itanium, and Xeon are trademarks or registered trademarks of Intel Corporation.

\*Other brands and names may be claimed as the property of others.

Copyright © Intel Corporation 2010.

# Table of Contents

<b>1. Product Overview</b>	<b>1</b>
1.1 Intel® Server Chassis SC5650 Design Features	1
1.2 Chassis Views	3
1.3 System Color	8
1.4 Chassis Security	8
1.5 I/O Panel	8
1.6 Rack and Cabinet Mounting Option	8
1.7 Front Bezel Features	9
1.8 Peripheral Bays	9
<b>2. Power Sub-system</b>	<b>10</b>
2.1 DP 600-Watt Power Supply	10
2.1.1 Mechanical Overview	11
2.1.2 Airflow and Temperature	12
2.1.3 Output Cable Harness	12
2.1.4 AC Input Requirements	17
2.1.5 DC Output Specifications	20
2.1.6 Protection Circuits	27
2.1.7 Current Limit (OCP)	27
2.1.8 FRU Data	30
2.2 600-W 1+1 Power Supply Module	30
2.2.1 Mechanical Overview	30
2.2.2 AC Input Requirements	33
2.2.3 DC Output Specification	38
2.2.4 Protection Circuits	44
2.2.5 Control and Indicator Functions	45
2.2.6 PMBus Monitoring Interface	48
2.3 600-W Power Distribution Board (PDB)	49
2.3.1 Mechanical Overview	50
2.3.2 DC Output Specification	55
2.3.3 Protection Circuits	60
2.3.4 Control and Indicator Functions (Hard-wired)	61
2.3.5 PMBus	63

2.4	1000-W Power Supply .....	64
2.4.1	Mechanical Overview .....	65
2.4.2	Airflow Requirements .....	67
2.4.3	Acoustic Requirements .....	67
2.4.4	Temperature Requirements .....	67
2.4.5	AC Input Voltage Requirements .....	68
2.4.6	DC Output Specification .....	73
2.4.7	Power Connectors .....	73
2.4.8	DC Output Specifications .....	77
2.4.9	Control and Indicator Functions .....	84
2.5	UP 400-Watt Power Supply .....	86
2.5.1	Mechanical Overview .....	86
2.5.2	Temperature Requirements .....	88
2.5.3	Output Cable Harness .....	88
2.5.4	AC Input Requirements .....	93
2.5.5	DC Output Specifications .....	95
2.5.6	Protection Circuits .....	100
2.5.7	Control and Indicator Functions .....	101
<b>3.</b>	<b>Chassis Cooling .....</b>	<b>104</b>
3.1	Fan Configuration .....	104
3.2	Server Board Fan Control .....	104
3.3	Cooling Solution .....	105
<b>4.</b>	<b>Peripheral and Hard Drive Support .....</b>	<b>107</b>
4.1	3.5-inch Peripheral Drive Bay .....	107
4.2	5.25-inch Peripheral Drive Bays .....	108
4.3	Hot Swap Hard Disk Drive Bays .....	108
4.3.1	Fixed Hard Drive Bay .....	108
4.3.2	Intel® Server Chassis SC5650 6HDD Passive SAS/SATA Hot Swap Back Plane (HSBP) Overview .....	109
4.3.3	Server Board and Storage Management Controller VSC410* .....	110
4.3.4	General Purpose Input/Output (GPIO) .....	113
4.3.5	External Memory Device .....	114
4.3.6	LEDs .....	114
4.3.7	SAS/SATA Drive Connectors .....	115
4.3.8	Power Connectors .....	115

4.3.9	Clock Generation and Distribution .....	116
4.3.10	7-Pin SAS/SATA Host Connectors .....	116
4.3.11	IPMB Header - IPMB .....	116
4.3.12	SGPIO Header - SGPIO .....	117
4.3.13	SES Header - SES .....	117
4.3.14	Passive Hot Swap Backplane (HSBP) Cables Explained.....	117
4.3.15	Connector Specifications .....	119
<b>5.</b>	<b>Standard Control Panel .....</b>	<b>120</b>
5.1	Control Panel .....	120
<b>6.</b>	<b>Inter Local Control Panel .....</b>	<b>122</b>
6.1	Internal Control Panel Headers .....	123
<b>7.</b>	<b>System Interconnection.....</b>	<b>124</b>
7.1	Signal Definitions .....	124
7.2	Chassis Internal Cables .....	124
7.2.1	Control Panel Cable.....	124
7.2.2	USB Cable .....	124
7.2.3	Fan Connector .....	124
7.2.4	Chassis Intrusion Cable .....	124
7.3	Server Board Internal Cables .....	124
7.4	Accessory Cables .....	125
7.5	I/O Panel Connectors .....	125
7.6	Spares and Accessories .....	125
<b>8.</b>	<b>Supported Intel® Server Boards .....</b>	<b>127</b>
<b>9.</b>	<b>Regulatory, Environmentals, and Specifications .....</b>	<b>128</b>
9.1	Product Regulatory Compliance .....	128
9.1.1	Product Safety Compliance .....	128
9.1.2	Product EMC Compliance – Class A Compliance .....	128
9.1.3	Product Ecology Requirements .....	129
9.1.4	Certifications / Registrations / Declarations .....	129
9.1.5	Product Regulatory Compliance Markings .....	130
9.2	Electromagnetic Compatibility Notices .....	131
9.2.1	FCC Verification Statement (USA) .....	131
9.2.2	ICES-003 (Canada) .....	132
9.2.3	Europe (CE Declaration of Conformity) .....	132
9.2.4	Japan EMC Compatibility .....	132

9.2.5	BSMI (Taiwan) .....	132
9.2.6	RRL (Korea).....	133
9.3	Regulated Specified Components .....	133
9.4	End of Life / Product Recycling.....	133
9.5	Restriction of Hazardous Substances (RoHS) Compliance.....	133
9.6	Replacing the Back up Battery .....	134
9.7	System-level Environmental Limits.....	134
9.8	Serviceability and Availability.....	135
9.9	Calculated MTBF .....	136
<b>Appendix A: Integration and Usage Tips.....</b>		<b>138</b>

# List of Figures

Figure 1. Front Closed Chassis View of Intel® Server Chassis SC5650.....	3
Figure 2. Rear Closed Chassis View of Intel® Server Chassis SC5650 (DP and UP configuration shown).....	5
Figure 3. Front Internal Chassis View of Intel® Server Chassis SC5650 (DP/WS/BRP configuration shown on the left, UP configuration shown on the right) .....	6
Figure 4. Rear Internal Chassis View of Intel® Server Chassis SC5650 (DP/WS/BRP configuration shown on the left, UP configuration shown on the right) .....	7
Figure 5. ATX 2.2 I/O Aperture .....	8
Figure 6. Mechanical Drawing for Power Supply Enclosure .....	11
Figure 7. Output Cable Harness for 600-W Power Supply .....	13
Figure 8. Output Voltage Timing .....	25
Figure 9. Turn On/Off Timing (Power Supply Signals).....	26
Figure 10. PSON# Required Signal Characteristics .....	29
Figure 11. Power Supply Enclosure - Dimensional Drawing .....	31
Figure 12. Output Voltage Timing .....	42
Figure 13. Turn On/Off Timing (Power Supply Signals).....	43
Figure 14. Mechanical Drawing for Dual (1+1 Configuration) Power Supply Enclosure.....	51
Figure 15. Output Voltage Timing .....	58
Figure 16. Turn On/Off Timing (Power Supply Signals).....	59
Figure 17. Mechanical Drawing of the 1000-W Power Supply Enclosure.....	66
Figure 18. LED Markings .....	68
Figure 19. Output Voltage Timing .....	81
Figure 20. Turn On/Off Timing (Power Supply Signals).....	82
Figure 21. Mechanical Drawing for Power Supply Enclosure .....	87
Figure 22. Output Cable Harness for 400-W Power Supply .....	90
Figure 23. Output Voltage Timing .....	99
Figure 24. Turn On/Off Timing (Power Supply Signals).....	100
Figure 25. PSON# Required Signal Characteristics .....	102
Figure 26. Cooling Fan Configuration for Intel® Server Boards S5520HC/S5500HCV/S5520SC above, S5500BC middle and S3420GP below.....	106
Figure 27. Drive Bay Locations for Intel® Server Chassis SC5650 (DP/WS/BRP configuration shown).....	107
Figure 28. 6HDD Passive SAS/SATA HSBP Block Diagram.....	110

Figure 29. Passive SAS/SATA HSBP I<sup>2</sup>C Bus Connection Diagram ..... 111

Figure 30. Intel® Server Chassis SC5650 6HDD Passive SAS/SATA HSBP Board Layout..... 118

Figure 31. Panel Controls and Indicators..... 120

Figure 32. SKU3 - Pedestal Server Application ..... 122

Figure 33. Local Control Panel Components ..... 122



# List of Tables

Table 1. Intel® Server Chassis SC5650 DP, BRP, WS and UP Features .....	2
Table 2. Thermal Environmental Requirements .....	12
Table 3. Cable Lengths .....	14
Table 4. P1 Baseboard Power Connector .....	14
Table 5. P2 Processor 0 Power Connector .....	15
Table 6. P3 Processor 1 Power Connector .....	15
Table 7. P4 Power Singal Connectors .....	15
Table 8. P5-P8 Peripheral Power Connector .....	16
Table 9. P9 Right-angle SATA Power Connector .....	17
Table 10. P10 SATA Power Connector .....	17
Table 11. AC Input Rating .....	18
Table 12. AC Line Sag Transient Performance .....	19
Table 13. AC Line Surge Transient Performance .....	20
Table 14. Load Ratings .....	21
Table 15. Voltage Regulation Limits .....	22
Table 16. Transient Load Requirements .....	22
Table 17. Capacitive Loading Conditions .....	23
Table 18. Ripple and Noise .....	24
Table 19. Output Voltage Timing .....	24
Table 20. Turn On / Off Timing .....	26
Table 21. Over Current Protection (OCP) .....	28
Table 22. Over Voltage Protection Limits .....	28
Table 23. PSON# Signal Characteristics .....	29
Table 24. PWOK Signal Characteristics .....	30
Table 25. Acoustic Requirements .....	32
Table 26. Thermal Requirements .....	32
Table 27. Efficiency .....	33
Table 28. AC Input Rating .....	34
Table 29. AC Line Sag Transient Performance .....	34
Table 30. AC Line Surge Transient Performance .....	34
Table 31. Performance Criteria .....	35
Table 32. Holdup Requirements .....	36

Table 33. Edge Finger Power Supply Connector Pin-out .....	38
Table 34. Power Supply Module Load Ratings .....	39
Table 35. Voltage Regulation Limits .....	40
Table 36. Transient Load Requirements .....	40
Table 37. Capacitive Loading Conditions .....	40
Table 38. Ripple and Noise .....	41
Table 39. Output Voltage Timing .....	41
Table 40. Turn On / Off Timing .....	42
Table 41. Over-current Protection (OCP) .....	44
Table 42. Over-voltage Protection Limits .....	45
Table 43. PSON# Signal Characteristic .....	46
Table 44. PSKILL Signal Characteristics .....	46
Table 45. PWOK Signal Characteristics .....	47
Table 46. LED Indicators .....	48
Table 47. Environmental Requirements .....	52
Table 48. Cable Lengths .....	52
Table 49. P1 Baseboard Power Connector .....	53
Table 50. P2 Processor 0 Power Connector .....	53
Table 51. P3 Processor 1 Power Connector .....	53
Table 52. P5, P6, P7, and P8 Peripheral Power Connectors .....	54
Table 53. P9 Right-angle SATA Power Connector .....	54
Table 54. P10 SATA Power Connector .....	55
Table 55. +12V Outputs Load Ratings .....	55
Table 56. DC/DC Converters Load Ratings .....	56
Table 57. Voltage Regulation Limits .....	56
Table 58. Transient Load Requirements .....	56
Table 59. Capacitive Loading Conditions .....	57
Table 60. Ripple and Noise .....	57
Table 61. Output Voltage Timing .....	58
Table 62. Turn On / Off Timing .....	59
Table 63. Over-current Protection Limits / 240VA Protection .....	60
Table 64. Over-voltage Protection (OVP) Limits .....	61
Table 65. PSON# Signal Characteristics .....	61
Table 66. PWOK Signal Characteristics .....	62
Table 67. SMBAlert# Signal Characteristics .....	63

Table 68. Sound Power Requirement.....	67
Table 69. Thermal Requirements .....	67
Table 70. AC Input Rating.....	68
Table 71. AC Line Sag Transient Performance .....	69
Table 72. AC Line Surge Transient Performance .....	69
Table 73. Performance Criteria.....	69
Table 74. AC Line Dropout / Holdup .....	70
Table 75. Efficiency.....	72
Table 76. Cable Lengths.....	73
Table 77. P1 Baseboard Power Connector .....	73
Table 78. P2 Processor 1 Power Connector.....	74
Table 79. P3 Processor 2 Power Connector.....	75
Table 80. P4 Power Signal Connector.....	75
Table 81. P5 PCI Express Connector .....	75
Table 82. P6 PCI Express Connector .....	76
Table 83. P9-P12 Peripheral Power Connectors .....	76
Table 84. P13 Right-angle SATA Power Connector .....	76
Table 85. P14 SATA Power Connector .....	76
Table 86. Load Ratings.....	77
Table 87. Pre-set Lighter Load .....	77
Table 88. Pre-set Lighter Voltage Regulation Limits.....	78
Table 89. Voltage Regulation Limits .....	79
Table 90. Transient Load Requirements.....	79
Table 91. Capacitive Loading Conditions .....	80
Table 92. Ripple and Noise.....	80
Table 93. Output Voltage Timing .....	81
Table 94. Turn On / Off Timing .....	81
Table 95. Over-current Protection (OCP) 240VA.....	83
Table 96. Over-voltage Protection Limits.....	83
Table 97. PSON# Signal Characteristic.....	84
Table 98. PWOK Signal Characteristics .....	85
Table 99. LED Indicators .....	85
Table 100. Thermal Environmental Requirements .....	88
Table 101. Cable Lengths.....	90
Table 102. P1 Main Power Connector .....	91

Table 103. P2 Processor #1 Power Connector.....	92
Table 104. Peripheral Power Connector.....	92
Table 105. Floppy Power Connector.....	92
Table 106. SATA Power Connector.....	92
Table 107. AC Input Rating.....	93
Table 108. Efficiency.....	93
Table 109. AC Line Sag Transient Performance.....	94
Table 110. AC Line Surge Transient Performance.....	94
Table 111. Load Ratings.....	96
Table 112. Voltage Regulation Limits.....	96
Table 113. Transient Load Requirements.....	97
Table 114. Capacitive Loading Conditions.....	97
Table 115. Ripple and Noise.....	98
Table 116. Output Voltage Timing.....	99
Table 117. Turn On / Off Timing.....	99
Table 118: <i>Over Voltage Protection (OVP) Limits</i> .....	101
Table 119. PSON# Signal Characteristics.....	101
Table 120. PWOK Signal Characteristics.....	102
Table 121. I <sup>2</sup> C Bus Addressing.....	112
Table 122. 6HDD I <sup>2</sup> C Bus Loading.....	112
Table 123. 6HDD VSC410* Controller GPIO Assignment.....	113
Table 124. LED Function.....	114
Table 125. 22-pin SAS/SATA Connector Pin-out.....	115
Table 126. Power Connector Pin-out.....	116
Table 127. 7-pin SAS/SATA Connector Pin-out.....	116
Table 128. IPMB Header Pin-out.....	116
Table 129. SGPIO Header Pin-out.....	117
Table 130. SES Header Pin-out.....	117
Table 131. 6HDD Passive SAS/SATA Hot Swap Backplane Connector Specifications.....	119
Table 132. Control Panel LED Functions.....	121
Table 133. IPMI Header.....	123
Table 134. System Office Environment Summary.....	135
Table 135. Mean Time To Repair Estimate.....	135
Table 136. Intel® Server Chassis SC5650 Component MTBF.....	136

**< This page intentionally left blank. >**



# 1. Product Overview

---

The Intel® Server Chassis SC5650 is a 5.2U pedestal chassis designed to support the Intel® Server Boards S5500BC, S5520HC/S5500HCV, S5520SC and S3420GP. This chapter provides a high-level overview of the chassis features. Greater detail for each major chassis component or feature is provided in the following chapters.

## 1.1 Intel® Server Chassis SC5650 Design Features

The Intel® Server Chassis SC5650 addresses the value server market with three power factor correction (PFC) power supply unit (PSU) configurations:

- SC5650DP – 600-W fixed PSU for dual-processor server boards
- SC5650WS – 1000-W fixed PSU for dual-processor workstation boards
- SC5650BRP – 600-W 1+0 redundant PSU for dual-processor server boards
- SC5650UP – 400-W fixed PSU for single-processor server boards

The DP, WS and UP power supply configurations each include an Intel validated PSU with an integrated cooling fan and one AC line input. The BRP power supply configuration includes (1 of 2) redundant Intel validated PSU (full redundancy requires an additional 600-W module) with an integrated cooling fan and two AC line inputs.

The cooling sub-system in the Intel® Server Chassis SC5650DP, SC5650WS and SC5650BRP consists of one 120-mm system fan, one 120-mm PCI fan and a 92-mm drive bay fan. While in the Intel® Server Chassis SC5650UP, it consists one 120-mm system fan and one 92-mm driver bay fan. A 92-mm drive bay fan is also included with the optional hot swap drive bay mounting bracket kit.

A removable access cover provides entry to the interior of the chassis. The rear I/O panel conforms to the *Advanced Technology Extended (ATX) Specification, Revision 2.2*. The chassis supports six full-length expansion cards. There are two front USB port connections, and one or two rear knock-out location for an optional rear mounted serial port. A control panel board designed for Server Standards Infrastructure (SSI) Entry E-Bay (EEB) 3.61-compliant server boards is also provided with the server chassis.

The Intel® Server Chassis SC5650 supports up to six hard drives in all four configurations. Two 5.25-inch, half-height drive bays are available for peripherals, such as CD/DVD-ROM drives and tape drives. An optional hot-swap SAS non-expander/SAS expander drive bay kit provides an upgrade path to allow the Intel® Server Chassis SC5650 to support up to six hot-swap drives. Refer to the *Drive Cage Upgrade Kit Installation Guide* for the Intel® Server Chassis SC5650 for complete hot swap drive cage installation instructions. When installed, the hot-swap drive bay replaces the fixed hard drive bay.

The Intel® Server Chassis SC5650 makes extensive use of tool-less hardware features that support tool-less installation and removal of fans, fixed and hot swap hard drives, fixed and hot swap drive bays, PCI cards, hot swap PSU modules, fixed PSU, floppy drives, and CD/DVD ROM drives.

This specification details the key features of the product. Reference documents listed at the back of this document provide additional product specification details for the server boards, backplanes, and power supplies validated for use with this chassis. Check the compatibility section on the support website for more details:

<http://support.intel.com/support/motherboards/server/chassis/SC5650/>.

The following table summarizes the features for all chassis combinations.

**Table 1. Intel® Server Chassis SC5650 DP, BRP, WS and UP Features**

Configuration	SC5650DP	SC5650BRP	SC5650WS	SC5650UP
Intel® Server Board Support	Intel® Server Board S5500BC Intel® Server Board S5520HC/ Intel® Server Board S5500HCV	Intel® Server Board S5500BC Intel® Server Board S5520HC/ Intel® Server Board S5500HCV	Intel® Server Board S5520SC	Intel® Server Board S3420GP
Power Delivery	600-W PFC Intel validated PSU with integrated cooling fan.	600-W PFC Intel validated PSU with integrated cooling fan. You can add one additional 600-W PSU for redundancy.	1000-W PFC Intel validated PSU with integrated cooling fan.	400-W PFC Intel validated PSU with integrated cooling fan.
FuSystem Cooling	One tool-less, 120-mm chassis fan. One tool-less 120-mm PCI fan. One tool-less 92-mm drive bay fan.			One tool-less, 120-mm chassis fan. One tool-less 92-mm drive bay fan.
Peripheral Bays	Two tool-less, multi-mount 5.25-inch peripheral bays. One standard 3.5-inch removable media peripheral bay.			
Drive Bays	Includes one tool-less fixed drive bay for up to six fixed drives.			
PCI Slots	Seven slots, six full-length, full-height PCI slots with tail card guide and one half-length PCI slot.			Full-length, full height PCI slot 5 and 6, half-length, full-height PCI slot 1-4.
Form Factor	5.2U tower, convertible to 6U rack mount.			
Front Panel	LEDs for NIC1, NIC2, HDD activity, power status, and system fault status. Switches for power, NMI, and reset. Integrated temperature sensor for fan speed management.			
External Front Connectors	Two USB ports			
Color	Black			



Configuration	SC5650DP	SC5650BRP	SC5650WS	SC5650UP
Construction	1.0-mm, zinc-plated sheet metal, meets Intel Cosmetic Spec # C25432			
Chassis ABS	Fire-retardant, non-brominated, PC-ABS			
Dimensions Pedestal	17.8 in (45.2 cm) x 9.256 in (23.5 cm) x 19 in (48.3 cm)			
Dimensions Rack	9.256 in (23.5 cm) x 17.6 in (44.7 cm) x 19 in (48.3 cm)			

## 1.2 Chassis Views

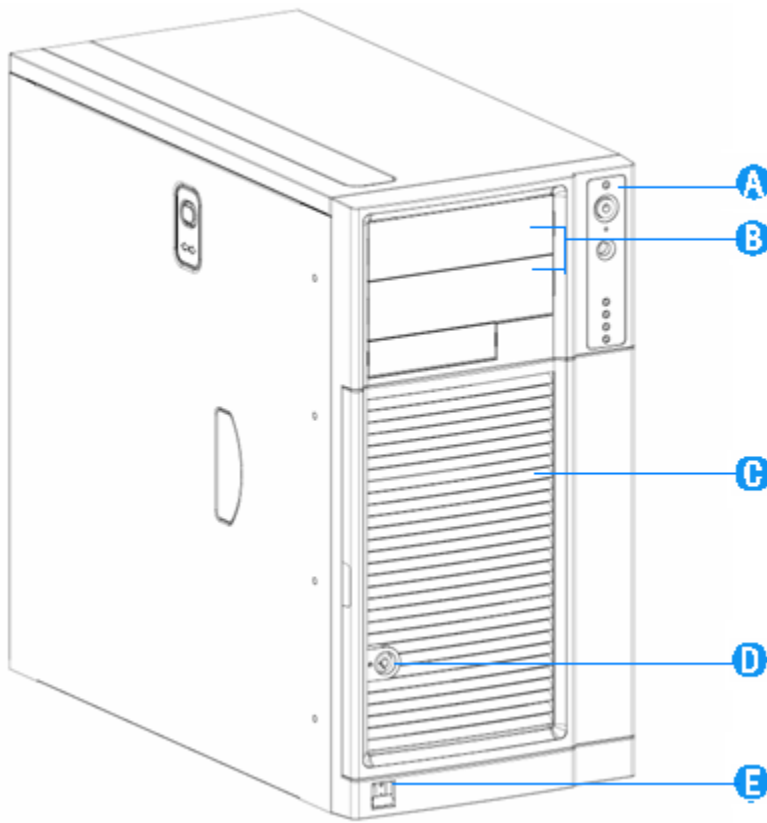

- A. Control panel controls and indicators
- B. Two half-height 5.25-inch peripheral drive bays
- C. Internal hard drive bay cage (behind door)
- D. Security lock
- E. USB ports

**Figure 1. Front Closed Chassis View of Intel® Server Chassis SC5650**

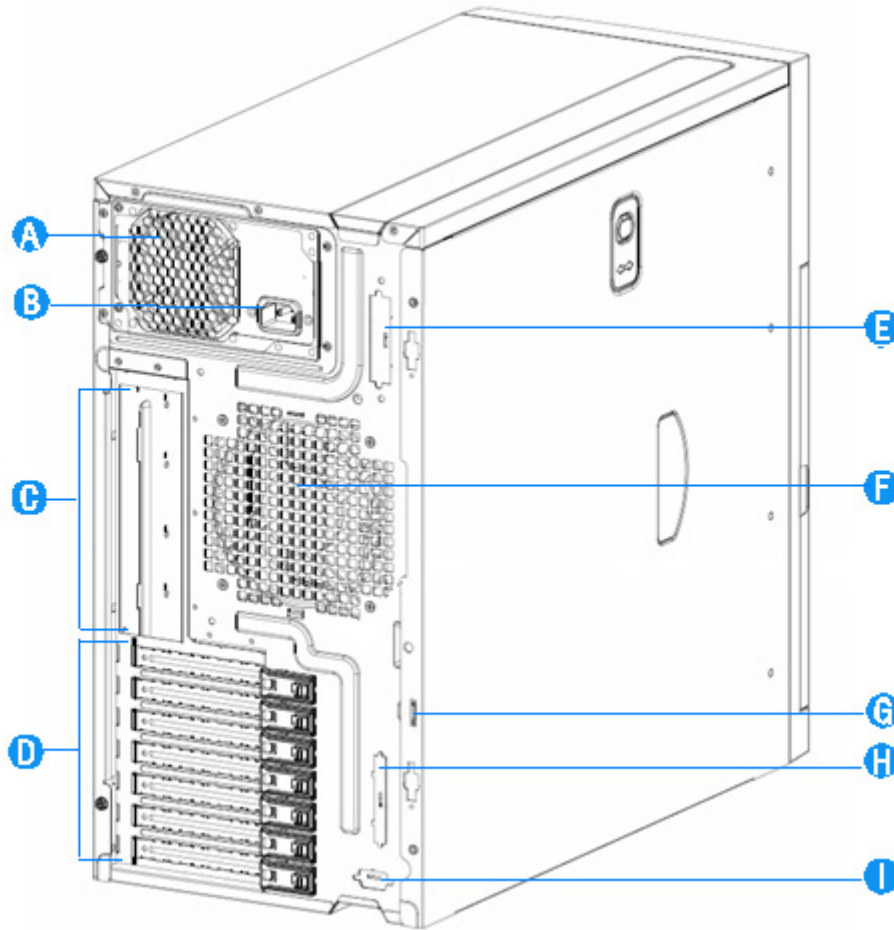

- A. Power supply (fixed power supply shown)
- B. AC input power connector
- C. I/O Ports
- D. Expansion slot covers
- E. Alternate external SCSI knockout
- F. 120-mm system fan
- G. Location to install padlock loop
- H. External SCSI knockout
- I. Alternate Serial B port knockout

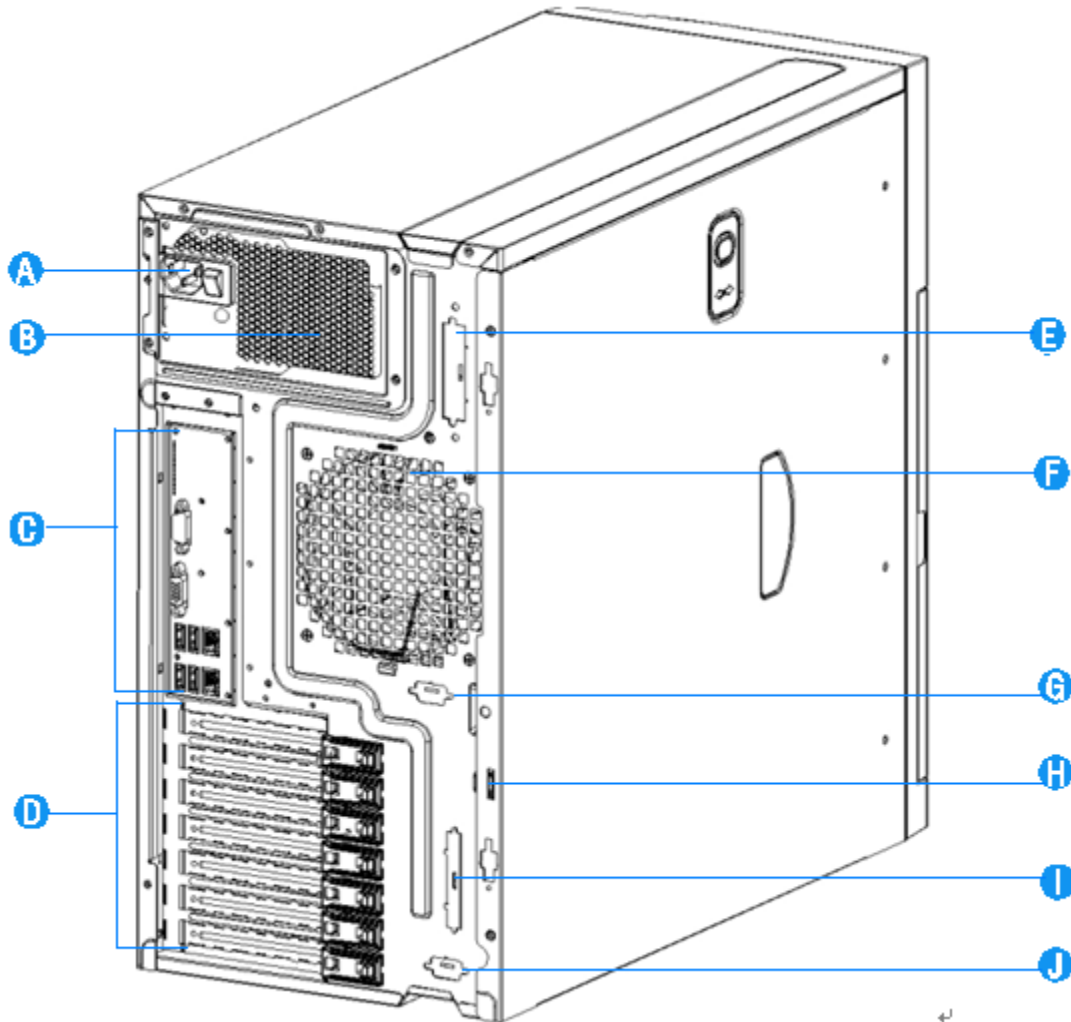

- A. Power supply (fixed power supply shown)
- B. AC input power connector
- C. I/O Ports
- D. Expansion slot covers
- E. Alternate external SCSI knockout
- F. 120-mm system fan
- G. Serial B port knockout
- H. Location to install padlock loop
- I. External SCSI knockout
- J. Alternate Serial B port knockout

**Figure 2. Rear Closed Chassis View of Intel® Server Chassis SC5650 (DP and UP configuration shown)**

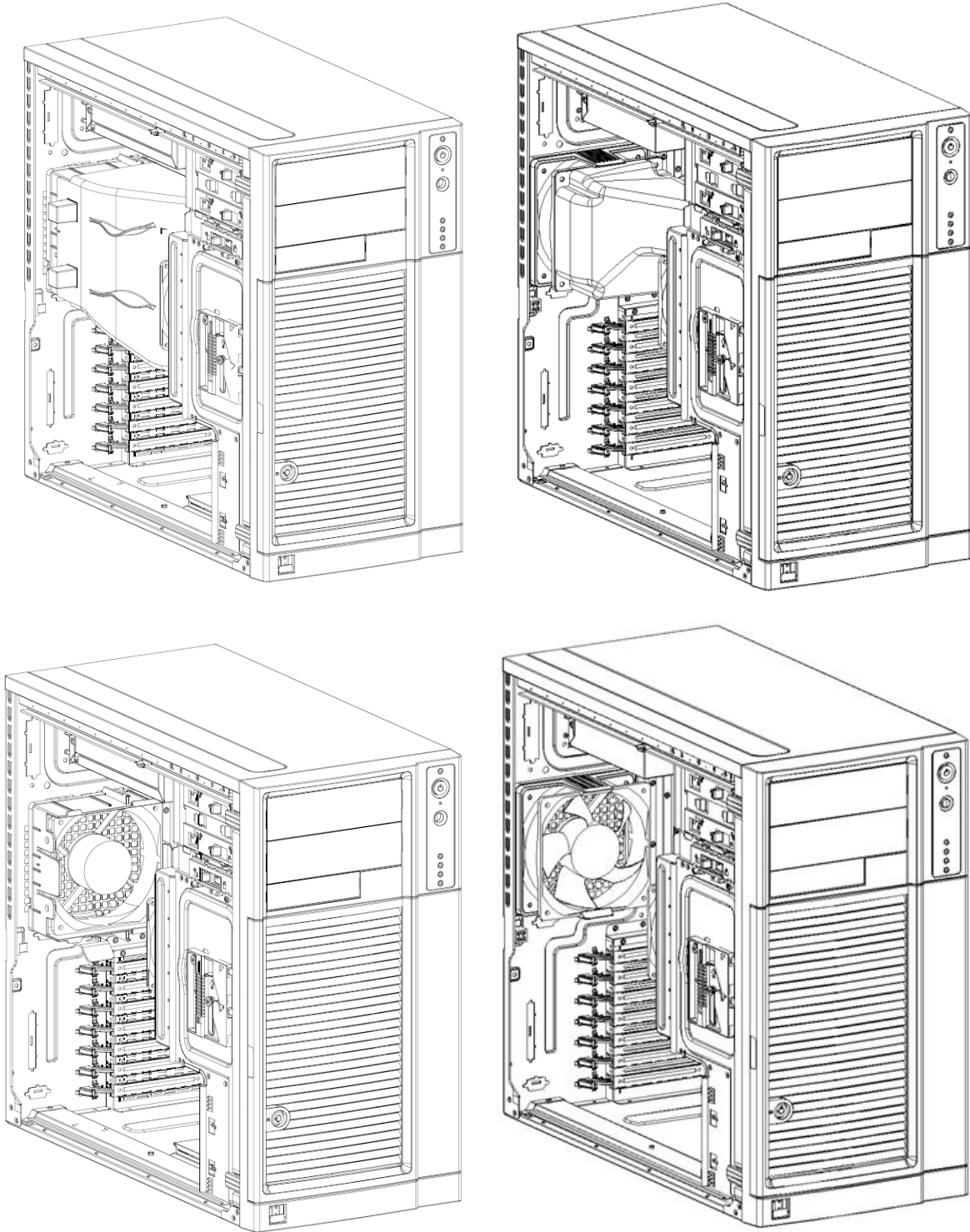

**Figure 3. Front Internal Chassis View of Intel® Server Chassis SC5650 (DP/WS/BRP configuration shown on the left, UP configuration shown on the right)**

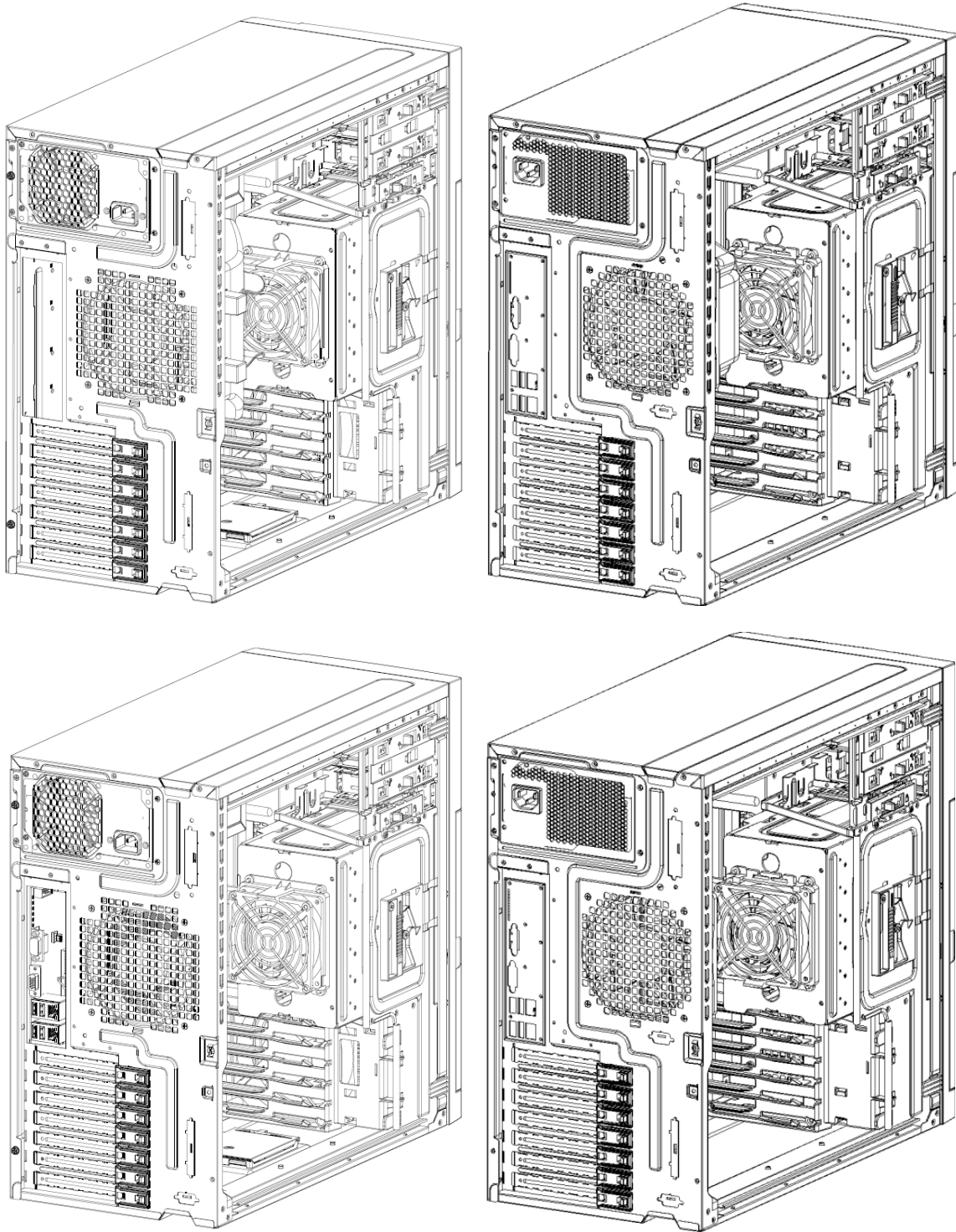

**Figure 4. Rear Internal Chassis View of Intel® Server Chassis SC5650 (DP/WS/BRP configuration shown on the left, UP configuration shown on the right)**

## 1.3 System Color

The Intel® Server Chassis SC5650 is offered in one color:

- Black (GE701)

## 1.4 Chassis Security

A variety of chassis security options are provided at the system level:

- A removable padlock loop at the rear of the system access cover can be used to prevent access to the microprocessors, memory, and add-in cards. A variety of lock sizes can be accommodated by the 0.270-inch diameter loop.
- A two-position key lock/switch will unlock the front bezel for DP, WS, BRP and UP configurations.
- A chassis intrusion switch is provided, allowing server management software to detect unauthorized access to the system side cover.

---

**Note:** See the technical product specification appropriate to the server board for a description of BIOS and management security features for each specific supported platform. You can find technical product specifications at [http://www.intel.com/p/en\\_US/support](http://www.intel.com/p/en_US/support).

---

## 1.5 I/O Panel

All input/output (I/O) connectors are accessible from the rear of the chassis. The SSI E-bay 3.61-compliant chassis provides an ATX 2.2-compatible cutout for I/O shield installation. Boxed Intel® server boards provide the required I/O shield for installation in the cutout. The I/O cutout dimensions are shown in the following figure for reference.

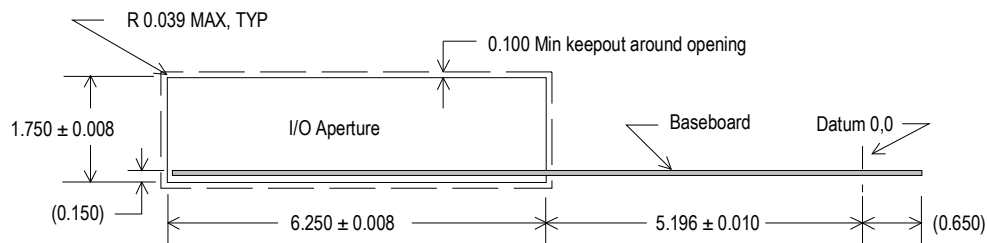

**Figure 5. ATX 2.2 I/O Aperture**

## 1.6 Rack and Cabinet Mounting Option

The Intel® Server Chassis SC5650 supports a rack mount configuration. The rack mount kit includes the chassis slide rails, rack handle, rack orientation label, screws, and manual. This rack mount kit is designed to meet the EIA-310-D enclosure specification. General rack compatibility is further described in the *Server Rack Cabinet Compatibility Guide* found at [http://www.intel.com/p/en\\_US/support](http://www.intel.com/p/en_US/support).

## 1.7 Front Bezel Features

The bezel is constructed of molded plastic and attaches to the front of the chassis with three clips on the right side and two snaps on the left. The snaps at the left attach behind the access cover, thereby preventing accidental removal of the bezel. The bezel can only be removed by first removing the server access cover. This provides additional security to the hard drive and peripheral bay area. The bezel also includes a key-locking door that covers the drive cage area and allows access to hot swap drives when a hot swap drive bay is installed.

The peripheral bays are covered with plastic snap-in cosmetic pieces that must be removed to add peripherals to the system. Control panel buttons and lights are located along the right side of the peripheral bays.

## 1.8 Peripheral Bays

Two 5.25-inch, half-height drive bays are available for CD/DVD-ROM or tape drives as well as one 3.5-inch removable media drive bay. Drive installation is tool-less and requires no screws.

## 2. Power Sub-system

---

### 2.1 DP 600-Watt Power Supply

The 600-W power supply specification defines a non-redundant power supply that supports DP Intel® Xeon® rack mount server systems. The 600-W power supply has eight outputs: 3.3V, 5V, 12V1, 12V2, 12V3, 12V4, -12V, and 5VSB. The form factor fits into a pedestal system and provides a wire harness output to the system. An IEC connector is provided on the external face for AC input to the power supply.

The power supply incorporates a Power Factor Correction circuit. The power supply is tested as described in EN 61000-3-2: Electromagnetic Compatibility (EMC) Part 3: Limits-Section 2: Limits for Harmonic Current Emissions, and meets the harmonic current emissions limits specified for ITE equipment.

The power supply is tested as described in the JEIDA MITI Guideline for Suppression of High Harmonics in Appliances and General-Use Equipment and meets the harmonic current emissions limits specified for ITE equipment.



### 2.1.1 Mechanical Overview

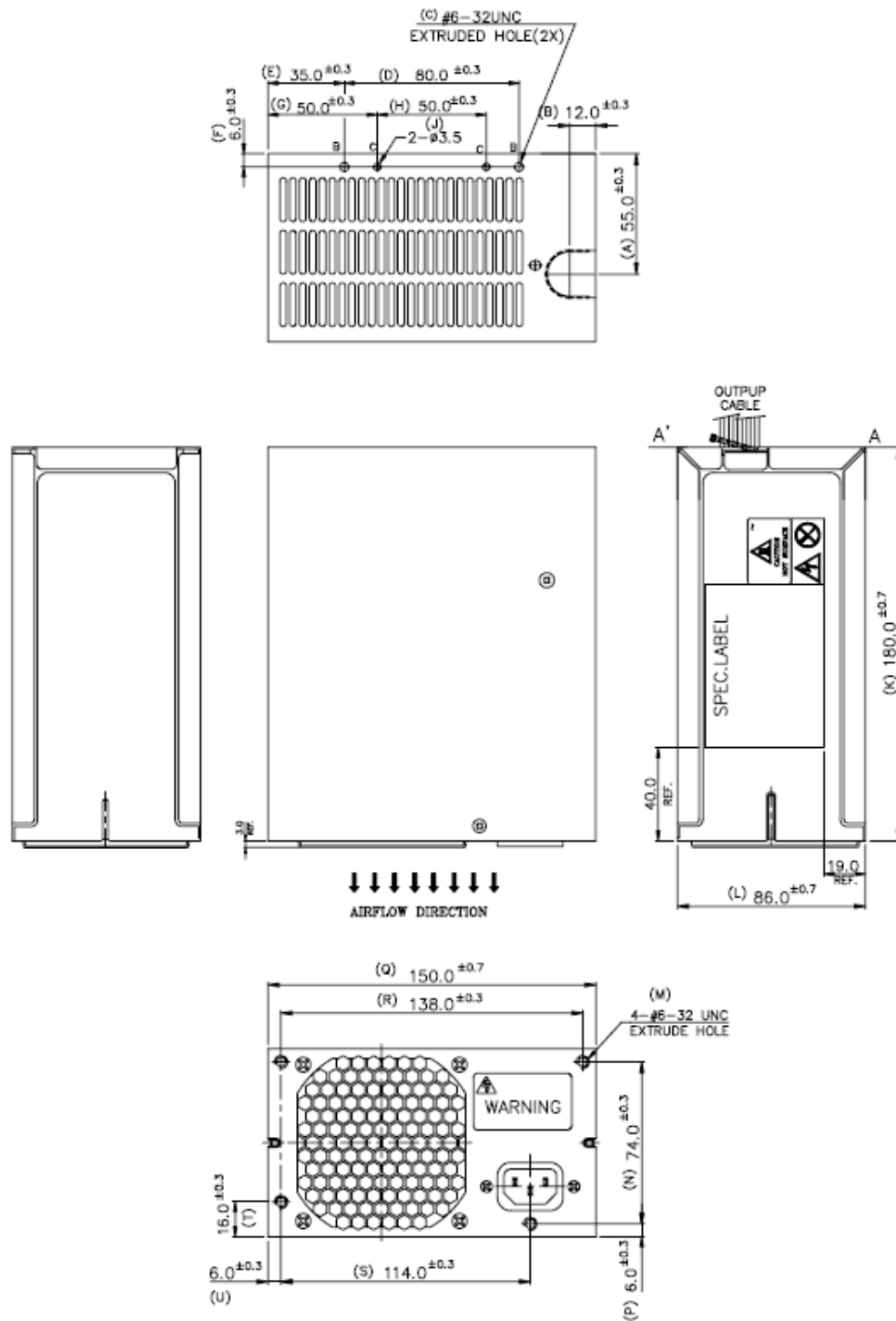

Figure 6. Mechanical Drawing for Power Supply Enclosure

### 2.1.2 Airflow and Temperature

The power supply incorporates one 80-mm fan for self and system cooling. The fan provides no less than 14 CFM of airflow through the power supply when installed in the system. The cooling air enters the power module from the non-AC side. The power supply operates within all specified limits over the  $T_{op}$  temperature range.

**Table 2. Thermal Environmental Requirements**

ITEM	DESCRIPTION	MIN	Specification	UNITS
$T_{op}$	Operating temperature range.	0	50	°C
$T_{non-op}$	Non-operating temperature range.	-40	70	°C
Altitude	Maximum operating altitude		3000	m

The power supply meets UL enclosure requirements for temperature rise limits. With the exception of the air exhaust side, all sides of the power supply are classified as “Handle, knobs, grips, etc. held for short periods of time only.”

### 2.1.3 Output Cable Harness

Listed or recognized component appliance wiring material (AVLV2), CN, rated min 105°C, 300Vdc is used for all output wiring.

P1 BASEBOARD POWER CONNECTOR

PIN	SIGNAL	COLOR	PIN	SIGNAL	COLOR
1	+3.3 VDC	ORANGE AWG#18	13	+3.3 VDC	ORANGE
	+3.3V R.S.	ORANGE AWG#24			
2	+3.3 VDC	ORANGE AWG#18	14	-12 VDC	BLUE
3	COM	BLACK AWG#18	15	COM	BLACK
	+5 VDC	RED AWG#18		16	PS_ON
4	+5V R.S.	RED AWG#24	17	COM	BLACK
	COM	BLACK		18	COM
5	RETURNS	BLACK AWG#24	19	COM	BLACK
	+5 VDC	RED		20	RESERVED
7	COM	BLACK	21	+5 VDC	RED
8	PWR OK	GRAY	22	+5 VDC	RED
9	5VSB	PURPLE	23	+5 VDC	RED
10	+12 V3	YELLOW	24	COM	BLACK
	+12V3 RS	YELLOW AWG#24			
11	+12 V3	YELLOW			
12	+3.3 VDC	ORANGE			

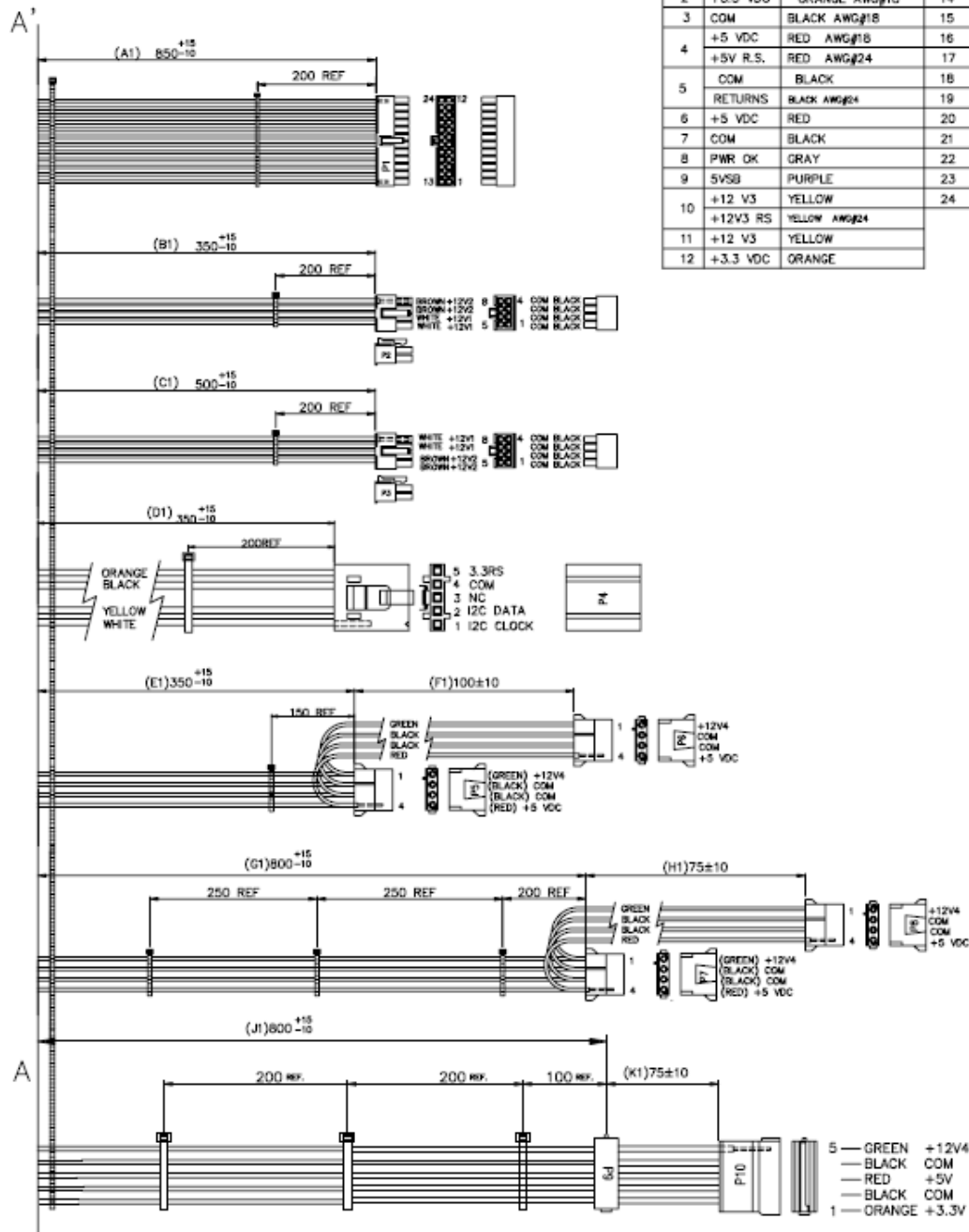

Figure 7. Output Cable Harness for 600-W Power Supply

NOTES:

1. ALL DIMENSIONS ARE IN MM
2. ALL TOLERANCES ARE +10 MM / -0 MM
3. INSTALL 1 TIE WRAP WITHIN 12MM OF THE PSU CAGE
4. MARK REFERENCE DESIGNATOR ON EACH CONNECTOR
5. TIE WRAP EACH HARNESS AT APPROX. MID POINT
6. TIE WRAP P1 WITH 2 TIES AT APPROXIMATELY 15M SPACING.

**Table 3. Cable Lengths**

From	To Connector #	Length (mm)	Number of Pins	Description
Power Supply cover exit hole	P1	850	24	Baseboard Power Connector
From	To Connector #	Length (mm)	Number of Pins	Description
Power Supply cover exit hole	P2	400	8	Processor 0 Power Connector
Power Supply cover exit hole	P3	400	8	Processor 1 Power Connector
Power Supply cover exit hole	P4	350	5	Power PSMI Connector
Power Supply cover exit hole	P5	350	4	Peripheral Power Connector
Extension	P6	100	4	Peripheral Power Connector
Power Supply cover exit hole	P7	800	4	Peripheral Power Connector
Extension	P8	75	4	Peripheral Power Connector
Power Supply cover exit hole	P9	800	5	Right-angle SATA Power Connector
Extension	P10	75	5	SATA Power Connector

### 2.1.3.1 P1 Baseboard Power Connector

Connector housing: 24-pin Molex\* Mini-Fit Jr. 39-01-2245 or equivalent

Contact: Molex\* 39-00-0059, or equivalent; Molex\* 44476-1111 for P10 & P11

**Table 4. P1 Baseboard Power Connector**

Pin	Signal	18 AWG Color	Pin	Signal	18 AWG Color
1	+3.3 VDC	Orange	13	+3.3 VDC	Orange
2	+3.3 VDC	Orange	14	-12 VDC	Blue
3	COM	Black	15	COM	Black
4	+5 VDC	Red	16	PSON#	Green
5	COM	Black	17	COM	Black
6	+5 VDC	Red	18	COM	Black
7	COM	Black	19	COM	Black
8	PWR OK	Gray	20	Reserved	N.C.
9	5VSB	Purple	21	+5 VDC	Red
10	+12V3	Yellow	22	+5 VDC	Red
11	+12V2	Yellow	23	+5 VDC	Red
12	+3.3 VDC	Orange	24	COM	Black

### 2.1.3.2 P2 Processor 0 Power Connector

Connector housing: 8-pin Molex\* 39-01-2085 or equivalent  
Contact: Molex\* 39-00-0059 or equivalent

**Table 5. P2 Processor 0 Power Connector**

Pin	Signal	18 AWG Color	Pin	Signal	18 AWG Color
1	COM	Black	5	+12V1	White
2	COM	Black	6	+12V1	White
3	COM	Black	7	+12V1	Brown
4	COM	Black	8	+12V1	Brown

### 2.1.3.3 P3 Processor 1 Power Connector

Connector housing: 8-pin Molex\* 39-01-2085 or equivalent  
Contact: Molex\* 39-00-0059 or equivalent

**Table 6. P3 Processor 1 Power Connector**

Pin	Signal	18 AWG Color	Pin	Signal	18 AWG Color
1	COM	Black	5	+12V1	Brown
2	COM	Black	6	+12V1	Brown
3	COM	Black	7	+12V1	White
4	COM	Black	8	+12V1	White

### 2.1.3.4 P4 Power Signal Connectors

Connector housing: 5-pin Molex\* 50-57-9405 or equivalent  
Contacts: Molex\* 16-02-0087 or equivalent

**Table 7. P4 Power Singal Connectors**

Pin	Signal	24 AWG Color
1	I <sup>2</sup> C Clock	White
2	I <sup>2</sup> C Data	Yellow
3	Reserved	N.C.
4	COM	Black
5	3.3RS	Orange

### 2.1.3.5 P5-P8 Peripheral Power Connector

Connector housing: AMP\* 770827-1 or equivalent  
Contact: AMP\* 61117-4, or equivalent

**Table 8. P5-P8 Peripheral Power Connector**

Pin	Signal	18 AWG Color
1	+12V4	Blue/White Stripe
2	COM	Black
3	COM	Black
4	+5Vdc	RED

### 2.1.3.6 P9 Right-angle SATA Power Connector

Connector Housing: JWT\* F6002HS0-5P-18 or equivalent

Contact: N/A

**Table 9. P9 Right-angle SATA Power Connector**

Pin	Signal	18 AWG Color
1	+3.3V	Orange
2	Ground	Black
3	+5V	Red
4	Ground	Black
5	+12V4	Green

### 2.1.3.7 P10 SATA Power Connector

Connector Housing: 5-pin Molex\* 67926-0011 or equivalent

Contact: Molex\* 67926-0041 or equivalent

**Table 10. P10 SATA Power Connector**

Pin	Signal	18 AWG Color
1	+3.3V	Orange
2	COM	Black
3	+5V	Red
4	COM	Black
5	+12V2	Blue/White

### 2.1.4 AC Input Requirements

The power supply operates within all specified limits over the following input voltage range, shown in the following table. Harmonic distortion of up to 10% of the rated line voltage must not cause the power supply to go out of specified limits. If the AC input is less than 75VAC +/-5VAC range, the power supply does power off. If the AC input is greater than 85VAC +/-4VAC, the power supply starts up. Application of an input voltage below 85VAC does not cause damage to the power supply, including a fuse blow.

**Table 11. AC Input Rating**

PARAMETER	MIN	Rated	MAX	Max Input Current	Start up VAC	Power Off VAC
Voltage (110)	90 V <sub>rms</sub>	100-127 V <sub>rms</sub>	140 V <sub>rms</sub>	10 A <sub>1,3</sub>	85Vac +/- 4Vac	75Vac +/- 5Vac
Voltage (220)	180 V <sub>rms</sub>	200-240 V <sub>rms</sub>	264 V <sub>rms</sub>	5 A <sub>2,3</sub>		
Frequency	47 Hz	50/60Hz	63 Hz			

**Notes:**

- 1 Maximum input current at low input voltage range should be measured at 90VAC, at max load.
- 2 Maximum input current at high input voltage range should be measured at 180VAC, at max load.
- 3 Do not use this requirement for determining agency input current markings.

**2.1.4.1 AC Inlet Connector**

The AC input connector is an IEC 320 C-14 power inlet. This inlet is rated for 10A / 250VAC.

**2.1.4.2 Efficiency**

The power supply has a recommended efficiency of 68% at maximum load and over the specified AC voltage.

**2.1.4.3 AC Line Dropout / Holdup**

An AC line dropout is defined to be when the AC input drops to 0VAC at any phase of the AC line for any length of time. During an AC dropout of one cycle or less the power supply meets dynamic voltage regulation requirements over the rated load. An AC line dropout of one cycle or less (20ms min) does not cause any tripping of control signals or protection circuits. If the AC dropout lasts longer than one cycle, the power recovers and meets all turn-on requirements. The power supply meets the AC dropout requirement over rated AC voltages, frequencies, and output loading conditions. Any dropout of the AC line does not cause damage to the power supply.

**2.1.4.3.1 AC Line 5VSB Holdup**

The 5VSB output voltage stays in regulation under its full load (static or dynamic) during an AC dropout of 70ms min (=5VSB holdup time) whether the power supply is in the ON or OFF state (PSON asserted or de-asserted).

**2.1.4.4 AC Line Fuse**

The power supply has a single line fuse on the Line (Hot) wire of the AC input. The line fusing is acceptable for all safety agency requirements. The input fuse is a slow blow type. AC inrush current does not cause the AC line fuse to blow under any conditions. All protection circuits in the power supply do not cause the AC fuse to blow unless a component in the power supply failed. This includes DC output load short conditions.



### 2.1.4.5 AC In-rush

AC line in-rush current does not exceed a 50 A peak, cold start @ 20 degrees C and no damage at hot start for up to one-quarter of the AC cycle, after which, the input current is no more than the specified maximum input current at 264 Vac input. The peak in-rush current is less than the ratings of its critical components (including input fuse, bulk rectifiers, and surge limiting device).

The power supply meets the in-rush requirements for any rated AC voltage during turn on at any phase of AC voltage, during a single cycle AC dropout condition as well as upon recovery after AC dropout of any duration, and over the specified temperature range ( $T_{op}$ ).

### 2.1.4.6 AC Line Surge

The power supply is tested with the system for immunity to AC Ringwave and AC Unidirectional wave, both up to 2kV, per EN 55024:1998, EN 61000-4-5:1995 and ANSI C62.45: 1992.

Pass criteria includes: No unsafe operation allowed under any conditions; all power supply output voltage levels must stay within proper specification levels; no change in operating state or loss of data during and after the test profile; no component damage under any conditions.

### 2.1.4.7 AC Line Transient Specification

AC line transient conditions are defined as “sag” and “surge” conditions. “Sag” conditions are also commonly referred to as “brownout,” and defined as AC line voltage drops below nominal voltage conditions. “Surge” is defined as AC line voltage rises above nominal voltage conditions.

The power supply meets requirements under the following AC line sag and surge conditions.

**Table 12. AC Line Sag Transient Performance**

Duration	Sag	Operating AC Voltage	Line Frequency	Performance Criteria
Continuous	10%	Nominal AC Voltage ranges	50/60Hz	No loss of function or performance
0 to 1 AC cycle	95%	Nominal AC Voltage ranges	50/60Hz	No loss of function or performance
> 1 AC cycle	>30%	Nominal AC Voltage ranges	50/60Hz	Loss of function acceptable, self recoverable

**Table 13. AC Line Surge Transient Performance**

Duration	Surge	Operating AC Voltage	Line Frequency	Performance Criteria
Continuous	10%	Nominal AC Voltages	50/60Hz	No loss of function or performance
0 to ½ AC cycle	30%	Mid-point of nominal AC Voltages	50/60Hz	No loss of function or performance

#### 2.1.4.8 AC Line Fast Transient (EFT) Specification

The power supply meets the EN 61000-4-5 directive and any additional requirements in IEC1000-4-5:1995 and the Level 3 requirements for surge-withstand capability with the following conditions and exceptions:

- These input transients do not cause any out-of-regulation conditions, such as overshoot and undershoot, nor do they cause any nuisance trips of any of the power supply protection circuits.
- The surge-withstand test does not produce damage to the power supply.
- The power supply meets surge-withstand test conditions under maximum and minimum DC-output load conditions.

#### 2.1.4.9 AC Line Leakage Current

The maximum leakage current to ground for each power supply is 3.5 mA when tested at 240 VAC.

### 2.1.5 DC Output Specifications

#### 2.1.5.1 Grounding

The ground of the pins of the power supply output connector provides the power return path. The output connector ground pins are connected to the safety ground (power supply enclosure).

#### 2.1.5.2 Standby Output

The 5 VSB output is present when an AC input greater than the power supply turn-on voltage is applied.

#### 2.1.5.3 Fanless Operation

Fanless operation is the power supply's ability to work indefinitely in standby mode with power on, power supply off, and the 5 VSB at full load (=2A) under environmental conditions (temperature, humidity, and altitude). In this mode, the components' maximum temperature should follow the same guidelines.

### 2.1.5.4 Remote Sense

The power supply has remote sense return (ReturnS) to regulate out ground drops for all output voltages: +3.3V, +5V, +12V1, +12V2, +12V3, +12V4, -12V, and 5VSB. The power supply uses remote sense to regulate out drops in the system for the +3.3V, +5V, and +12V1 output. The +5V, +12V1, +12V2, +12V3, +12V4, -12V, and 5VSB outputs only use remote sense referenced to the ReturnS signal. The remote sense input impedance to the power supply is greater than 200Ω. This is the value of the resistor connecting the remote sense to the output voltage internal to the power supply. Remote sense can regulate out a minimum of 200mV drop. The remote sense return (ReturnS) can regulate out a minimum of 200 mV drop in the power ground return. The current in any remote sense line is less than 5mA to prevent voltage sensing errors. The power supply operates within specification over the full range of voltage drops from the power supply's output connector to the remote sense points.

### 2.1.5.5 Power Module Output Power / Currents

The following table defines power and current ratings for this 600-W power supply. The combined output power of all outputs does not exceed the rated output power. The following are load ranges for each of the two power supply power levels. The power supply meets both static and dynamic voltage regulation requirements for the minimum loading conditions.

**Table 14. Load Ratings**

#### Load Range 1 (Maximum System Loading)

Voltage	Minimum Continuous Load	Maximum Continuous Load <sup>1,3</sup>	Peak Load <sup>2,4,5</sup>
+3.3V <sup>6</sup>	1.5 A	20 A	
+5V <sup>6</sup>	5.0 A	24 A	
+12V1	1.5 A	15 A	18 A
+12V2	1.5 A	15 A	18 A
+12V3	1.5 A	16 A	18 A
+12V4	1.5 A	16 A	18 A
-12V	0 A	0.5 A	
+5VSB	0.1 A	2.0 A	

#### Load Range 2 (Light System Loading)

Voltage	Minimum Continuous Load	Maximum Continuous Load	Peak Load <sup>5</sup>
+3.3V <sup>6</sup>	0.5 A	9.0 A	
+5V <sup>6</sup>	2.0 A	7.0 A	
+12V1	0.5 A	5.0 A	7.0 A
+12V2	0.5 A	5.0 A	7.0 A
+12V3	2.0 A	6.0 A	
+12V4	0.5 A	5.0 A	
-12V	0 A	0.5 A	

Voltage	Minimum Continuous Load	Maximum Continuous Load	Peak Load5
+5VSB	0.1 A	2.0 A	

**Notes:**

1. Maximum continuous total DC output power should not exceed 600 W.
2. Peak load on the combined 12-V output should not exceed 48 A.
3. Maximum continuous load on the combined 12-V output should not exceed 43 A.
4. Peak total DC output power should not exceed 660 W.
5. Peak power and peak current loading should be supported for a minimum of 12 seconds.
6. Combined 3.3 V/5 V power should not exceed 140 W.

### 2.1.5.6 Voltage Regulation

The power supply output voltages are within the following voltage limits when operating at steady state and dynamic loading conditions. These limits include the peak-peak ripple/noise. All outputs are measured with reference to the return remote sense signal (ReturnS). The +12V3, +12V4, -12V, and 5VSB outputs are measured at the power supply connectors referenced to ReturnS. The +3.3V, +5V, +12V1, and +12V2 are measured at the remote sense signal located at the signal connector.

**Table 15. Voltage Regulation Limits**

Parameter	Tolerance	MIN	NOM	MAX	Units
+ 3.3V	- 5% / +5%	+3.14	+3.30	+3.46	V <sub>rms</sub>
+ 5V	- 5% / +5%	+4.75	+5.00	+5.25	V <sub>rms</sub>
+ 12V1	- 5% / +5%	+11.40	+12.00	+12.60	V <sub>rms</sub>
+ 12V2	- 5% / +5%	+11.40	+12.00	+12.60	V <sub>rms</sub>
+12V3	- 5% / +5%	+11.40	+12.00	+12.60	V <sub>rms</sub>
+12V4	- 5% / +5%	+11.40	+12.00	+12.60	V <sub>rms</sub>
- 12V	- 5% / +9%	-11.40	-12.00	-13.08	V <sub>rms</sub>
+ 5VSB	- 5% / +5%	+4.75	+5.00	+5.25	V <sub>rms</sub>

### 2.1.5.7 Dynamic Loading

The output voltages are within the limits specified for the step loading and capacitive loading requirements specified in the following table. The load transient repetition rate is tested between 50 Hz and 5 kHz at duty cycles ranging from 10%-90%. The load transient repetition rate is only a test specification. The  $\Delta$  step load may occur anywhere within the MIN load and MAX load conditions.

**Table 16. Transient Load Requirements**

Output	$\Delta$ Step Load Size 1, 2	Load Slew Rate	Test Capacitive Load
+3.3 V	7.0 A	0.25 A/ $\mu$ sec	4700 $\mu$ F

Output	Δ Step Load Size 1, 2	Load Slew Rate	Test Capacitive Load
+5 V	7.0 A	0.25 A/μsec	1000 μF
+12 V	25 A	0.25 A/μsec	2700 μF
+5 VSB	0.5 A	0.25 A/μsec	20 μF

### 2.1.5.8 Capacitive Loading

The power supply is stable and meets all requirements with the following capacitive loading ranges.

**Table 17. Capacitive Loading Conditions**

Output	MIN	MAX	Units
+3.3V	10	12,000	μF
+5V	10	12,000	μF
+12V(1, 2, 3)	500 each	11,000	μF
+12V4	10	500	μF
-12V	1	350	μF
+5VSB	20	350	μF

### 2.1.5.9 Closed Loop Stability

The power supply is unconditionally stable under all line/load/transient load conditions including capacitive load ranges in Section 2.1.5.8. A minimum of a 45-degree phase margin and -10dB-gain margin is required. Closed-loop stability is ensured at the maximum and minimum loads as applicable.

### 2.1.5.10 Residual Voltage Immunity in Standby Mode

The power supply is immune to any residual voltage placed on its outputs (typically a leakage voltage through the system from standby output) up to 500mV. There is neither additional heat generated nor stressing of any internal components with this voltage applied to any individual output or all outputs simultaneously. Residual voltage also does not trip the protection circuits during turn on/off.

The residual voltage at the power supply outputs for a no-load condition does not exceed 100 mV when AC voltage is applied.

### 2.1.5.11 Common Mode Noise

The Common Mode noise on any output does not exceed 350mV pk-pk over the frequency band of 10Hz to 30MHz. The measurement is made across a 100Ω resistor between each of the DC outputs including ground at the DC power connector and chassis ground (power subsystem enclosure). The test set-up uses an FET probe, such as a Tektronix\* P6046, or equivalent.

### 2.1.5.12 Ripple / Noise

The maximum allowed ripple/noise output of the power supply is defined in the following table. This is measured over a bandwidth of 10 Hz to 20 MHz at the power supply output connectors. A 10μF tantalum capacitor in parallel with a 0.1μF ceramic capacitor is placed at the point of measurement.

**Table 18. Ripple and Noise**

+3.3V	+5V	+12V(1,2,3,4)	-12V	+5VSB
50mVp-p	50mVp-p	120mVp-p	120mVp-p	50mVp-p

### 2.1.5.13 Timing Requirements

The timing requirements for power supply operation are as follows. The output voltages must rise from 10% to within regulation limits ( $T_{vout\_rise}$ ) within 5 to 70ms, except for 5VSB which is allowed to rise from 1.0 to 25ms. The +3.3V, +5V and +12V output voltages start to rise at approximately the same time. All outputs must rise monotonically. The 5V output must be greater than the +3.3V output during any point of the voltage rise. The +5V output must never be greater than the +3.3V output by more than 2.25V. Each output voltage reaches regulation within 50 ms ( $T_{vout\_on}$ ) of each other during turn on of the power supply. Each output voltage falls out of regulation within 400msec ( $T_{vout\_off}$ ) of each other during turn off. The following table shows the timing requirements for the power supply being turned on and off via the AC input with PSON held low and the PSON signal with the AC input applied.

**Table 19. Output Voltage Timing**

Item	Description	Minimum	Maximum	Units
$T_{vout\_rise}$	Output voltage rise time from each main output.	5.0*	70*	msec
$T_{vout\_on}$	All main outputs must be within regulation of each other within this time.		50	msec
$T_{vout\_off}$	All main outputs must leave regulation within this time.		400	msec

- The 5VSB output voltage rise time should be from 1.0 ms to 25 ms.

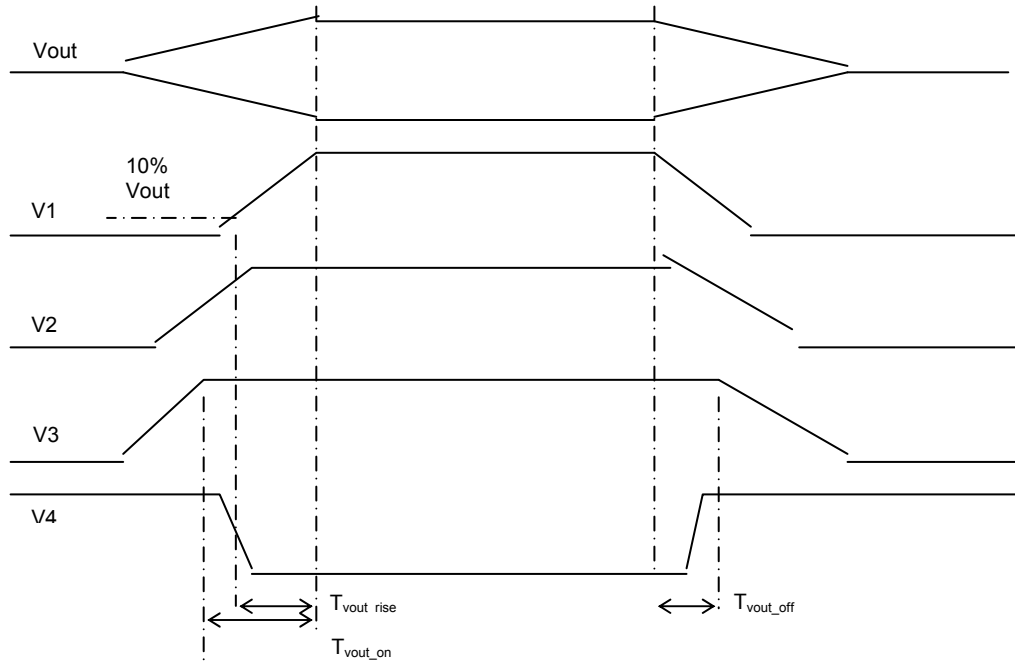

**Figure 8. Output Voltage Timing**

**Table 20. Turn On / Off Timing**

Item	Description	Minimum	Maximum	Units
$T_{sb\_on\_delay}$	Delay from AC being applied to 5VSB being within regulation.		1500	msec
$T_{ac\_on\_delay}$	Delay from AC being applied to all output voltages being within regulation.		2500	msec
$T_{vout\_holdup}$	Time all output voltages stay within regulation after loss of AC.	21		msec
$T_{pwok\_holdup}$	Delay from loss of AC to de-assertion of PWOK.	20		msec
$T_{pson\_on\_delay}$	Delay from PSON# active to output voltages within regulation limits.	5	400	msec
$T_{pson\_pwok}$	Delay from PSON# deactive to PWOK being de-asserted.		50	msec
$T_{pwok\_on}$	Delay from output voltages within regulation limits to PWOK asserted at turn on.	100	1000	msec
$T_{pwok\_off}$	Delay from PWOK de-asserted to output voltages (3.3 V, 5 V, 12 V, and -12 V) dropping out of regulation limits.	1	200	msec
$T_{pwok\_low}$	Duration of PWOK being in the de-asserted state during an off/on cycle using AC or the PSON signal.	100		msec
$T_{sb\_vout}$	Delay from 5 VSB being in regulation to O/Ps being in regulation at AC turn on.	50	1000	msec
$T_{5VSB\_holdup}$	Time the 5 VSB output voltage stays within regulation after loss of AC.	70		msec

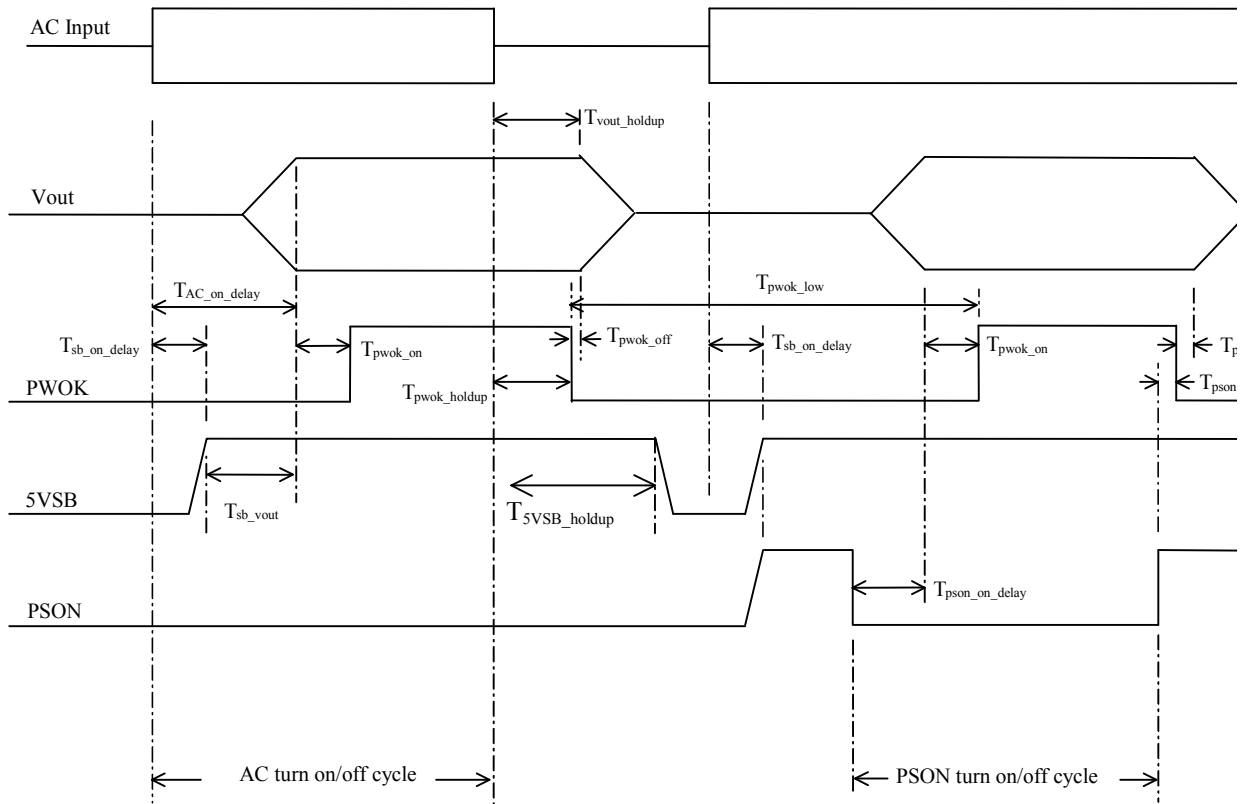

**Figure 9. Turn On/Off Timing (Power Supply Signals)**



## 2.1.6 Protection Circuits

Protection circuits inside the power supply cause only the power supply's main outputs to shut down. If the power supply latches off due to a protection circuit tripping, an AC cycle OFF for 15 seconds and a PSON# cycle HIGH for 1 second resets the power supply.

## 2.1.7 Current Limit (OCP)

The power supply has a current limit to prevent the +3.3V, +5V, and +12V outputs from exceeding the values shown in the following table. If the current limits are exceeded, the power supply shuts down and latches off. The latch is cleared by either toggling the PSON# signal or by an AC power interruption. The power supply is not damaged from repeated power cycling in this condition. -12 V and 5 VSB are protected under over current or shorted conditions so no damage occurs to the power supply. 5 VSB will auto-recover after the OCP limit is removed.

**Table 21. Over Current Protection (OCP)**

VOLTAGE	OVER CURRENT LIMIT	
	Min	Max
+3.3 V	26.4 A	36 A
+5 V	26.4 A	36 A
+12 V1	18 A	20 A
+12 V2	18 A	20 A
+12 V3	18 A	20 A
+12 V4	18 A	20 A
-12 V	0.625 A	4 A
5 VSB	N/A	8 A

### 2.1.7.1 Over Voltage Protection (OVP)

The power supply over voltage protection is locally sensed. After an over-voltage condition occurs, the power supply shuts down and latches off. You can clear this latch by toggling the PSON<sup>#</sup> signal or by an AC power interruption. The following table contains the over voltage limits. The values are measured at the output of the power supply's pins. The voltage never exceeds the maximum levels when measured at the power pins of the power supply connector during any single point of fail. The voltage will not trip any lower than the minimum levels when measured at the power pins of the power supply connector. After the OVP condition is removed, +5 VSB will auto-recover.

**Table 22. Over Voltage Protection Limits**

Output Voltage	MIN (V)	MAX (V)
+3.3 V	3.9 V	4.5 V
+5 V	5.7 V	6.5 V
+12 V1,2,3,4	13.3 V	14.5 V
-12 V	-13.3 V	-16 V
+5 VSB	5.7 V	6.5 V

### 2.1.7.2 Over Temperature Protection (OTP)

The power supply is protected against over temperature conditions caused by loss of fan cooling or excessive ambient temperature. In an OTP condition, the power supply shuts down. When the power supply temperature drops to within specified limits, the power supply restores power automatically, while the 5 VSB will always remain on. The OTP circuit has a built-in hysteresis such that the power supply will not oscillate on and off due to a temperature recovering condition. The OTP trip level has a minimum of 4°C of ambient temperature hysteresis.

### 2.1.7.3 PSON# Input Signal

The PSON# signal is required to remotely turn on/off the power supply. PSON# is an active low signal that turns on the +3.3V, +5V, +12V, and -12V power rails. When this signal is not pulled low by the system or left open, the outputs (except the +5VSB) turn off. This signal is pulled to a standby voltage by a pull-up resistor internal to the power supply. Refer to the following table and figure for PSON# signal characteristics.

**Table 23. PSON# Signal Characteristics**

Signal Type	Accepts an open collector/drain input from the system. Pull-up to 5 V located in power supply.	
PSON# = Low	ON	
PSON# = High or Open	OFF	
	<b>MIN</b>	<b>MAX</b>
Logic level low (power supply ON)	0V	1.0V
Logic level high (power supply OFF)	2.1V	5.25V
Source current, Vpson = low		4mA
Power up delay: $T_{pson\_on\_delay}$	5 msec	400 msec
PWOK delay: $T_{pson\_pwok}$		50 msec

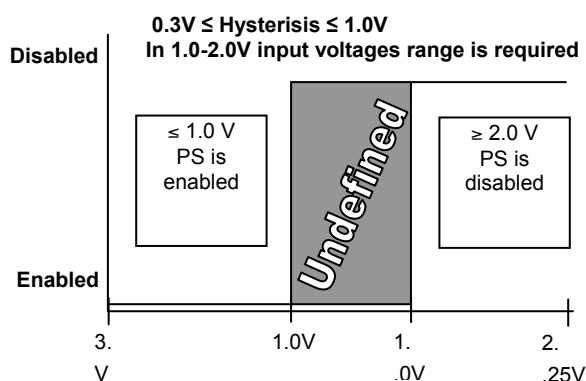

**Figure 10. PSON# Required Signal Characteristics**

### 2.1.7.4 PWOK (Power OK) Output Signal

PWOK is a power OK signal and is pulled HIGH by the power supply to indicate all the outputs are within the regulation limits of the power supply. When any output voltage falls below regulation limits or when AC power is removed for a time sufficiently long so the power supply operation is no longer guaranteed, PWOK is de-asserted to a LOW state. The start of the PWOK delay time is inhibited as long as any power supply output is within current limit.

**Table 24. PWOK Signal Characteristics**

Signal Type	Open collector/drain output from power supply. Pull-up to VSB located in system.	
PWOK = High	Power OK	
PWOK = Low	Power Not OK	
	<b>MIN</b>	<b>MAX</b>
Logic level low voltage, Isink=4mA	0 V	0.4 V
Logic level high voltage, Isource=200µA	2.4 V	5.25 V
Sink current, PWOK = low		4m A
Source current, PWOK = high		2m A
PWOK delay: $T_{pwok\_on}$	100 ms	1000 ms
PWOK rise and fall time		100µsec
Power down delay: $T_{pwok\_off}$	1 ms	200 msec

## 2.1.8 FRU Data

The FRU data format is compliant with the IPMI, version 1.0 (per rev.1.1 from Sept.25, 1999) specification. The current version of these specifications is available at: <http://developer.intel.com/design/servers/ipmi/spec.htm>.

### 2.1.8.1 Device Address Locations

The power supply device address location is as follows:

Power Supply FRU Device	A0h
-------------------------	-----

## 2.2 600-W 1+1 Power Supply Module

The 600-W power supply module specification defines a 1+1 power supply module that supports pedestal server systems. It defines a 600-W power supply with 2 outputs: +12Vdc and +5Vsb. A separate cage (including power distribution board) is designed to plug directly to the output connector of the PS module and provide additional power converters to produce other required voltages. An IEC connector is provided on the external face for AC input to the power supply. The power supply contains cooling fans, while meeting acoustic requirements.

### 2.2.1 Mechanical Overview

The 1+1 configuration of 600-W power supply enclosure dimensional drawing is shown:

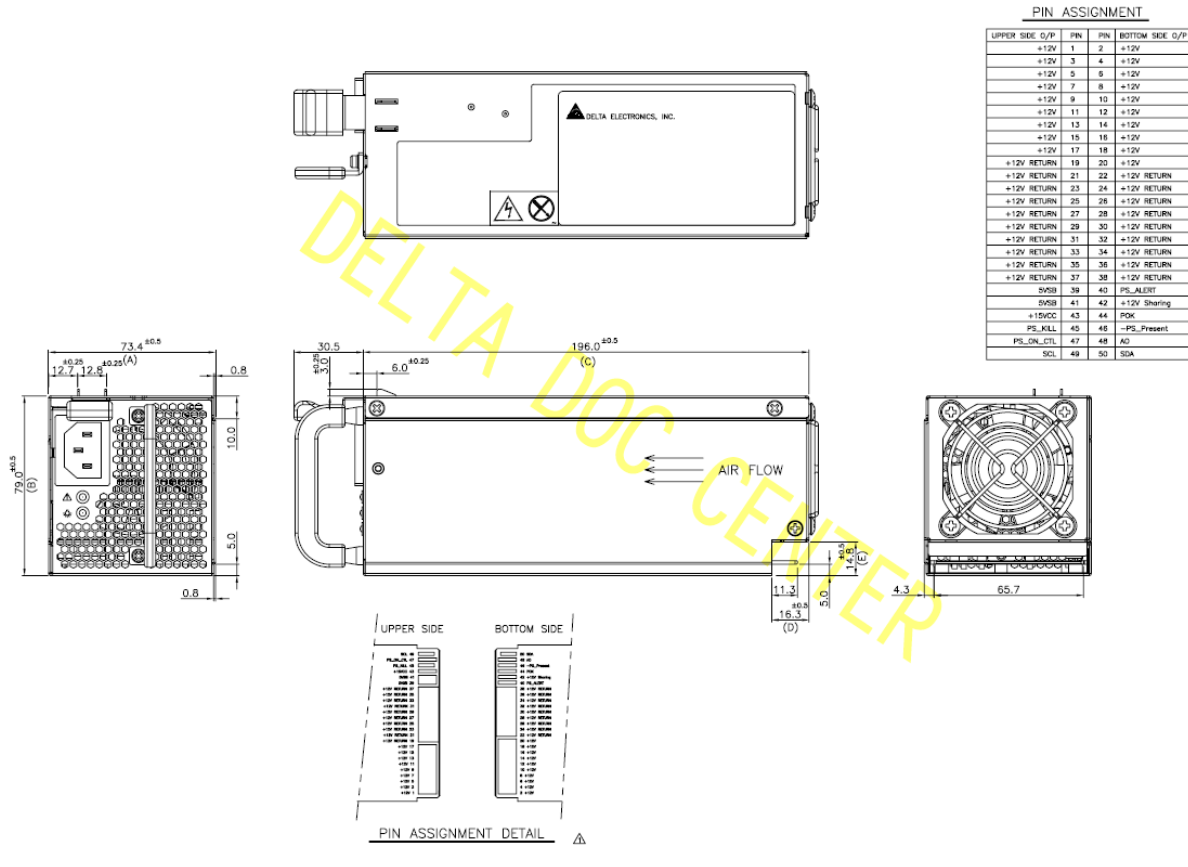

Figure 11. Power Supply Enclosure - Dimensional Drawing

### 2.2.1.1 Handle and Retention Mechanism

The power supply has a handle to provide a place to grip the power supply for removal and insertion. The power supply has a simple retention mechanism to retain the power supply once it is inserted. This mechanism withstands the specified mechanical shock and vibration requirements. The tab on the retention mechanism is green to indicate it is a hot-swap touch point. The latch mechanism is designed in such a way as to prevent inserting the power supply with the power cord plugged in. This aid in the hot swapping procedure: on removal, the power cord is unplugged first, then the power supply is removed; on insertion, the power supply is inserted first and then the power cord is plugged in.

The handle protects the operator from any burn hazard. You can use a metal handle only if the temperature remains less than 55 degrees when running at maximum load under maximum ambient temperature conditions.

A plastic handle is molded from the following material:

Material	Color	Designation
GE 2800	Green	GN3058
BAYER FR2000	Green	3200

### 2.2.1.2 Acoustic and Fan Speed Control Requirements

Sound power levels emitted by the power supply meet the requirements shown in the following table. Sound power is measured as described in ISO7779. Under a condition where inlet air temperature exceeds the limit, sound power level may exceed the limit.

The power supply incorporates a variable speed fan. The fan speed varies linearly based on output loading and ambient temperature. The declared sound power levels (LwAd) of the power supply unit (PSU) meet the requirements shown in the following table. Sound power is measured according to ECMA 74 ([www.ecma-international.org](http://www.ecma-international.org)) and reported according to ISO 9296.

The acoustic measurement of the power supply is performed with the power supply fan operating at the RPM corresponding to the operating conditions shown in the following table.

The PSU acoustic test report should include at a minimum the following information: power supply dimensions, picture, fan model and size, fan voltage (or duty cycle), and RPM and PSU sound power level at each operating condition. The proper RPM thermally sustainable is determined through PSU thermal testing and should be submitted as an appendix to the acoustic test report.

The cage should be tested in a 1+0 non-redundant configuration and a 1+1 redundant configuration.

**Table 25. Acoustic Requirements**

Operating Conditions	Inlet Temperature Condition	% of Single module Maximum Loading Condition	LwAd (BA)
Maximum (1+0 & 1+1)	45°C	100%	< 6.5
Operating (1+0 & 1+1)	40°C	60%	< 5.2
Idle (1+0 & 1+1)	35°C	40%	< 4.0

### 2.2.1.3 Temperature Requirements

The power supply operates within all specified limits over the  $T_{op}$  temperature range described in the following table. The average air temperature difference ( $\Delta T_{ps}$ ) from the inlet to the outlet of the power supply does not exceed 20 degrees C. All airflow passes through the power supply and not over the exterior surfaces of the power supply.

**Table 26. Thermal Requirements**

Item	Description	MIN	Max	Units
$T_{op}$	Operating temperature range	0	45	°C
$T_{non-op}$	Non-operating temperature range	-40	70	°C
Altitude	Maximum operating altitude		1524 (5,000)	m (ft)

The power supply meets UL enclosure requirements for temperature rise limits. All sides of the power supply, with exception of the air exhaust side, are classified as “Handle, knobs, grips, etc., held for short periods of time only.” You must pay special attention to the fan case temperature; it cannot be exceeded under any conditions.

#### 2.2.1.4 LED Marking and Identification

The LED is green or amber when lit.

### 2.2.2 AC Input Requirements

The 600-W power supply incorporates a universal power input with active power factor correction, which reduces line harmonics in accordance with the EN61000-3-2 and JEIDA MITI standards.

#### 2.2.2.1 AC Inlet Connector

The AC input connector is an IEC 320 C-14 power inlet. This inlet is rated for 10A/250VAC.

#### 2.2.2.2 Efficiency

The following table provides the required minimum efficiency level at four loading conditions: 100%, 50%, 20% and 10%. Efficiency is tested at the AC input voltage 230VAC.

**Table 27. Efficiency**

Loading	100% of Maximum	50% of Maximum	20% of Maximum	10% of Maximum
Efficiency	85%	89%	85%	75%
Power Factor	> 0.9	> 0.9	> 0.85	> 0.75

#### 2.2.2.3 AC Input Voltage Specification

The power supply operates within all specified limits over the following input voltage range, as shown in the following table. Harmonic distortion of up to 10% of rated AC input voltage will not cause the power supply to go out of specified limits. The power supply powers off at or below 75 VAC +/-5 VAC range. The power supply starts up at or above 85 VAC +/-4VAC. Application of an input voltage below 85 VAC does not cause damage to the power supply, including a fuse blow.

**Table 28. AC Input Rating**

Parameter	MIN	Rated	MAX	Start up VAC	Power Off VAC	Max Input Current	Max Rated Input AC Current
Line Voltage (110)	90 V <sub>rms</sub>	100-127 V <sub>rms</sub>	140 V <sub>rms</sub>	85Vac +/- 4Vac	75Vac +/- 5Vac	TBD A <sub>rms</sub> <sup>1,3</sup>	TBD A <sub>rms</sub> <sup>4</sup>
Line Voltage (220)	180 V <sub>rms</sub>	200-240 V <sub>rms</sub>	264 V <sub>rms</sub>			TBD A <sub>rms</sub> <sup>2,3</sup>	TBD A <sub>rms</sub> <sup>4</sup>
Frequency	47 Hz	50/60Hz	63 Hz				

**Notes:**

- 1 Maximum input current at low input voltage range should be measured at 90Vac at max load.
- 2 Maximum input current at high input voltage range should be measured at 180VAC at max load.
- 3 This is not to be used for determining agency input current markings.
- 4 Maximum rated input current is measured at 100 VAC and 200 VAC.

**2.2.2.4 AC Line Transient Specification**

AC line transient conditions are defined as “sag” and “surge” conditions. “Sag” conditions are also commonly referred to as “brownout” and defined as AC line voltage drops below nominal voltage conditions. “Surge” is defined as AC line voltage rises above nominal voltage conditions. The power supply meets requirements under the following AC line sag and surge conditions.

**Table 29. AC Line Sag Transient Performance**

Duration	Sag	Operating AC Voltage	Line Frequency	Loading	Performance Criteria
Continuous	10%	Nominal AC Voltage ranges	50/60 Hz	100%	No loss of function or performance
0 to 1 AC cycle	100%	Nominal AC Voltage ranges	50/60 Hz	75%	No loss of function or performance
> 1 AC cycle	>10%	Nominal AC Voltage ranges	50/60 Hz	100%	Loss of function acceptable, self recoverable

**Table 30. AC Line Surge Transient Performance**

Duration	Surge	Operating AC Voltage	Line Frequency	Performance Criteria
Continuous	10%	Nominal AC Voltages	50/60 Hz	No loss of function or performance
0 to ½ AC cycle	30%	Mid-point of nominal AC Voltages	50/60 Hz	No loss of function or performance

**2.2.2.5 AC Line Fuse**

The power supply has a single line fuse on the Line (Hot) wire of the AC input. The line fusing is acceptable for all safety agency requirements. The input fuse is a slow blow type. AC inrush current will not cause the AC line fuse to blow under any conditions. All protection circuits in the power supply will not cause the AC fuse to blow unless a component in the power supply failed. This includes DC output load short conditions.



### 2.2.2.6 AC In-rush

AC line in-rush current does not exceed 55A peak for up to one-quarter of the AC cycle, after which the input current is no more than the specified maximum input current. The peak in-rush current is less than the ratings of its critical components (including input fuse, bulk rectifiers, and surge limiting device).

The power supply meets the in-rush requirements for any rated AC voltage, during turn on at any phase of AC voltage, during a single cycle AC dropout condition, as well as upon recovery after AC dropout of any duration, and over the specified temperature range ( $T_{op}$ ).

### 2.2.2.7 Susceptibility Requirements

The power supply meets the following electrical immunity requirements when connected to a cage with an external EMI filter that meets the criteria defined in the SSI document EPS Power Supply Specification. For further information on Intel standards, please request a copy of the *Intel Environmental Standards Handbook*.

**Table 31. Performance Criteria**

Level	Description
A	The apparatus should continue to operate as intended. No degradation of performance.
B	The apparatus should continue to operate as intended. No degradation of performance beyond spec limits.
C	Temporary loss of function is allowed provided the function is self-recoverable or restorable by the operation of the controls.

#### 2.2.2.7.1 Electrostatic Discharge Susceptibility

The power supply complies with the limits defined in EN 55024: 1998 using the IEC 61000-4-2:1995 test standard and performance criteria B defined in Annex B of CISPR 24.

#### 2.2.2.7.2 Fast Transient/Burst

The power supply complies with the limits defined in EN55024: 1998 using the IEC 61000-4-4:1995 test standard and performance criteria B defined in Annex B of CISPR 24.

#### 2.2.2.7.3 Radiated Immunity

The power supply complies with the limits defined in EN55024: 1998 using the IEC 61000-4-3:1995 test standard and performance criteria A defined in Annex B of CISPR 24.

#### 2.2.2.7.4 Surge Immunity

The power supply was tested with the system for immunity to AC Ringwave and AC Unidirectional wave, both up to 2kV, per EN 55024:1998, EN 61000-4-5:1995 and ANSI C62.45: 1992.

The pass criteria included: No unsafe operation allowed under any condition; all power supply output voltage levels remain within proper spec levels; no change in operating state or loss of data during and after the test profile; no component damage under any condition.

The power supply complies with the limits defined in EN55024: 1998 using the IEC 61000-4-5:1995 test standard and performance criteria B defined in Annex B of CISPR 24.

### 2.2.2.8 AC Line Dropout / Holdup

The following are the AC dropout requirements.

**Table 32. Holdup Requirements**

Loading	Holdup Time
100%	12 msec
60%	20 msec

An AC line dropout is defined to be when the AC input drops to 0VAC at any phase of the AC line for any length of time. During an AC dropout condition, the power supply meets dynamic voltage regulation requirements. An AC line dropout of any duration will not cause tripping of control signals or protection circuits. If the AC dropout lasts longer than the hold-up time, the power supply recovers and meets all turn-on requirements. The power supply meets the AC dropout requirement over rated AC voltages and frequencies. A dropout of the AC line for any duration will not cause damage to the power supply.

#### 2.2.2.8.1 AC Line 5VSB Holdup

The 5 VSB output voltage stays in regulation under its full load (static or dynamic) during an AC dropout of 70 ms min (=5VSB holdup time) whether the power supply is in an ON or OFF state (PSON asserted or de-asserted).

### 2.2.2.9 AC Line Fast Transient (EFT) Specification

The power supply meets the EN61000-4-5 directive and any additional requirements in IEC1000-4-5: 1995 and the Level 3 requirements for surge-withstand capability, with the following conditions and exceptions:

- These input transients do not cause any out-of-regulation conditions, such as overshoot and undershoot, nor do they cause any nuisance trips of any of the power supply protection circuits.
- The surge-withstand test must not produce damage to the power supply.
- The supply meets surge-withstand conditions under maximum and minimum DC-output load conditions.

#### 2.2.2.10 AC Line Leakage Current

The maximum leakage current to ground for each power supply should not be more than 3.5mA when tested at 240 VAC.

### 2.2.2.11 Power Recovery

The power supply recovers automatically after an AC power failure. AC power failure is defined to be any loss of AC power that exceeds the dropout criteria.

#### 2.2.2.11.1 Voltage Brown Out

The power supply complies with the limits defined in EN55024: 1998 using the IEC 61000-4-11:1995 test standard and performance criteria C defined in Annex B of CISPR 24.

In addition, the power supply meets the following Intel Requirement:

- A continuous input voltage below the nominal input range should not damage the power supply or cause overstress to any power supply component. The power supply must be able to return to normal power up state after a brownout condition. Maximum input current under a continuous brownout should not blow the fuse. The power supply should tolerate a 3-minute ramp from 90 VAC voltage to 0 VAC after the components have reached a steady state condition.

#### 2.2.2.11.2 Voltage Interruptions

The power supply complies with the limits defined in EN55024: 1998 using the IEC 61000-4-11:1995 test standard and performance criteria C defined in Annex B of CISPR 24.

### 2.2.2.12 AC Line Isolation Requirements

The power supply meets all safety agency requirements for dielectric strength. Transformers' isolation between primary and secondary windings complies with the 3000 Vac (4242Vdc) dielectric strength criteria. If the working voltage between primary and secondary dictates a higher di-electric strength test voltage, the highest test voltage is used. In addition, the insulation system complies with reinforced insulation per safety standard IEC 950. Separation between the primary and secondary circuits, and primary to ground circuits, complies with the IEC 950 spacing requirements.

### 2.2.2.13 Power Factor Correction

The power supply incorporates a power factor correction circuit.

The power supply was tested as described in the EN 61000-3-2: Electromagnetic Compatibility (EMC) Part 3: Limits- Section 2: Limits for harmonic current emissions, and meets the harmonic current emissions limits specified for ITE equipment.

The power factor must be higher than 0.85 at 20% load and 230VAC.

The power supply was tested as described in the JEIDA MITI Guideline for Suppression of High Harmonics in Appliances and General-Use Equipment and meets the harmonic current emissions limits specified for ITE equipment.

## 2.2.3 DC Output Specification

### 2.2.3.1 Connector

The power supply provides card edge fingers, which mate to a connector located inside the system. It is a blind-mating type of connector that connects the power supply's output voltages and signals. The card edge finger pin assignments are defined in the following table.

**Table 33. Edge Finger Power Supply Connector Pin-out**

Connector	Upper Side	Pin No Top.	Pin No. Bottom	Bottom Side
Gold finger edge connector: 2X25	+12 V	1	2	+12 V
	+12 V	3	4	+12 V
	+12 V	5	6	+12 V
	+12 V	7	8	+12 V
	+12 V	9	10	+12 V
	+12 V	11	12	+12 V
	+12 V	13	14	+12 V
	+12 V	15	16	+12 V
	+12 V	17	18	+12 V
	+12 V Return	19	20	+12 V Return
	+12 V Return	21	22	+12 V Return
	+12 V Return	23	24	+12 V Return
	+12 V Return	25	26	+12 V Return
	+12 V Return	27	28	+12 V Return
	+12 V Return	29	30	+12 V Return
	+12 V Return	31	32	+12 V Return
	+12 V Return	33	34	+12 V Return
	+12 V Return	35	36	+12 V Return
	+12 V Return	37	38	+12 V Return
	5 VSB	39	40	ALERT
	5 VSB	41	42	+12 V Sharing
	+15 VCC	43	44	POK
	PS_KILL	45	46	-PS_Present
	PS_ON_CTL	47	48	A0
SCL	49	50	-OVER_TEMP	

Signals that are defined as low true or high true use the following convention:

Signal# = low true

Reserved pins are reserved for future use.

### 2.2.3.2 Grounding

The ground of the pins of the power supply output connector provides the power return path. The output connector ground pins are connected to safety ground (power supply enclosure). This grounding is well-designed to ensure passing the maximum allowed Common Mode Noise levels.

A reliable protective earth ground is provided on the power supply. All secondary circuits are connected to protective earth ground. Resistance of the ground returns to chassis does not exceed 1.0 mΩ. This path may be used to carry DC current.

### 2.2.3.3 Remote Sense

No remote sense and remote sense return signal is required on this power supply. The power supply operates within specification over the full range of voltages at the power supply's output connector.

### 2.2.3.4 Output Power / Currents

The following table defines power and current ratings for the 600-W continuous power supply in a 1+0 or 1+1 redundant configuration. The combined output power of both outputs does not exceed the rated output power. The power supply meets both static and dynamic voltage regulation requirements for the minimum loading conditions. Also, the power supply supplies the listed peak currents and power for a minimum of 10 seconds. Outputs are not required to be peak loaded simultaneously.

**Table 34. Power Supply Module Load Ratings**

Voltage	600-W		
	Min	Max	Peak
+12 V	0.6 A	49 A	54 A
+5 VSB	0.1 A	3.0 A	3.5 A

### 2.2.3.5 Standby Output

The 5VSB output is present when an AC input greater than the power supply turn-on voltage is applied.

### 2.2.3.6 Voltage Regulation

The power supply output voltages stay within the following voltage limits when operating at steady state and dynamic loading conditions. These limits include the peak-peak ripple/noise specified in the Voltage Regulation Limits table. All outputs are measured with reference to the GND. The +12V and +5VSB outputs are measured at the power distribution board output harness connector.

**Table 35. Voltage Regulation Limits**

Parameter	Tolerance	MIN	NOM	MAX	Units
+ 12V	- 5% / +5%	+11.40	+12.00	+12.60	V <sub>rms</sub>
+ 5VSB	- 5% / +5%	+4.75	+5.00	+5.25	V <sub>rms</sub>

### 2.2.3.7 Dynamic Loading

The output voltages remain within limits specified for the step loading and capacitive loading presented in the following table. The load transient repetition rate was tested between 5 Hz and 5 kHz at duty cycles ranging from 10%-90%. The load transient repetition rate is only a test specification. The  $\Delta$  step load may occur anywhere between the MIN load and MAX load defined in the following table.

**Table 36. Transient Load Requirements**

Output	Max $\Delta$ Step Load Size	Max Load Slew Rate	Test Capacitive Load
12 V	32.0 A <sup>1</sup>	0.5 A/ $\mu$ s	2200 $\mu$ F
+5 VSB	0.5 A	0.5 A/ $\mu$ s	20 $\mu$ F

**Notes:**

1. Step loads on each 12V output may happen simultaneously.
2. The +12V should be tested with 2200  $\mu$ F evenly split between the three +12V rails.

### 2.2.3.8 Capacitive Loading

The power supply is stable and meets all requirements with the following capacitive loading ranges. Minimum capacitive loading applies to static load only.

**Table 37. Capacitive Loading Conditions**

Output	MIN	MAX	Units
+12V	2000	11,000	$\mu$ F
+5VSB	1	350	$\mu$ F

### 2.2.3.9 Closed Loop Stability

The power supply is unconditionally stable under all line/load/transient load conditions, including capacitive load ranges. A minimum 45-degree phase margin and -10dB-gain margin is met. Closed-loop stability is ensured at the maximum and minimum loads, as applicable.

### 2.2.3.10 Common Mode Noise

The Common Mode Noise on any output does not exceed 350mV pk-pk over the frequency band of 10 Hz to 20 MHz.

### 2.2.3.11 Ripple / Noise

The maximum ripple/noise output of the power supply is defined in the following table. This is measured over a bandwidth of 0Hz to 20MHz at the power supply output connectors. A 10 $\mu$ F tantalum capacitor in parallel with a 0.1 $\mu$ F ceramic capacitor is placed at the point of measurement.

**Table 38. Ripple and Noise**

+12V Output	+5VSB Output
120mVp-p	50mVp-p

### 2.2.3.12 Forced Load Sharing

The +12V output has forced load sharing. The output shares within 10% at full load. All current sharing functions are implemented internal to the power supply by making use of the 12LS signal. The power distribution board connects the 12LS signal between the two power supplies. The failure of a power supply does not affect the load sharing or output voltages of the other supplies still operating. The supplies are able to load share with up to two power supplies in parallel and can operate in a hot-swap / redundant 1+1 configuration. The 5Vsb output is not required to actively share current between power supplies (passive sharing). The 5Vsb outputs of the power supplies are connected together in the system so that a failure or hot swap of a redundant power supply does not cause these outputs to go out of regulation in the system.

### 2.2.3.13 Timing Requirements

The timing requirements for power supply operation are as follows. The output voltages must rise from 10% to within regulation limits ( $T_{vout\_rise}$ ) within 5 to 70 ms except for 5VSB, which is allowed to rise from 1.0 to 25 ms. All outputs rise monotonically. The following figure shows the timing requirements for the power supply being turned on and off via the AC input, with PSON held low and the PSON signal with the AC input applied.

**Table 39. Output Voltage Timing**

Item	Description	Minimum	Maximum	Units
$T_{vout\_rise}$	Output voltage rise time from each main output.	5.0*	70*	msec
$T_{vout\_on}$	All main outputs must be within regulation of each other within this time.		50	msec
$T_{vout\_off}$	All main outputs must leave regulation within this time.		400	msec

- The 5VSB output voltage rise time should be from 1.0 ms to 25.0 ms.

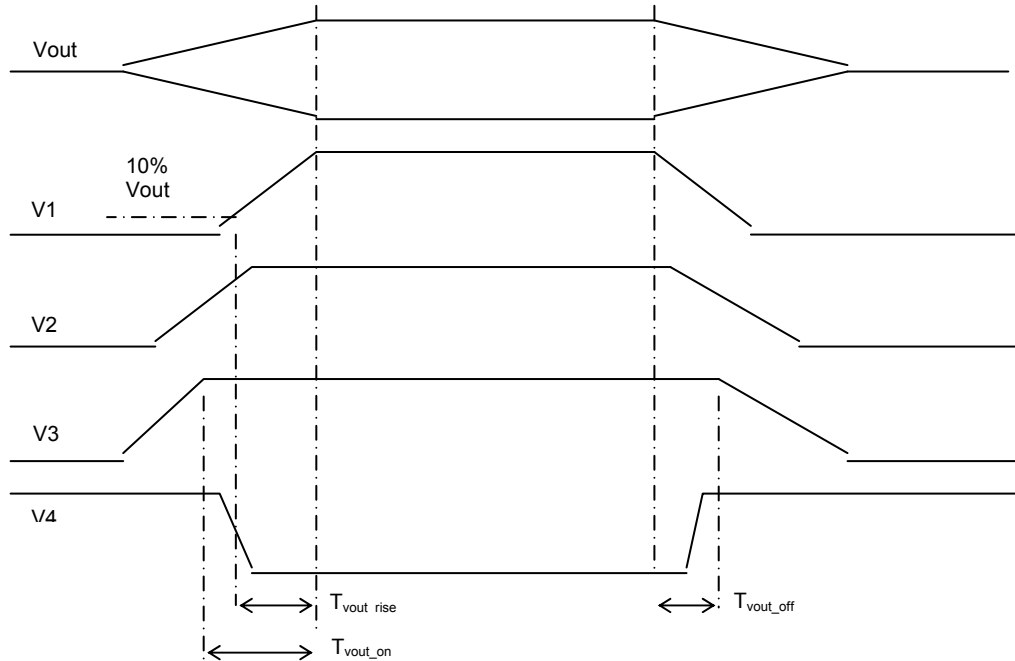

**Figure 12. Output Voltage Timing**

**Table 40. Turn On / Off Timing**

Item	Description	Minimum	Maximum	Units
$T_{sb\_on\_delay}$	Delay from AC being applied to 5 VSB being within regulation.		1500	ms
$T_{ac\_on\_delay}$	Delay from AC being applied to all output voltages being within regulation.		2500	ms
$T_{vout\_holdup}$	Time all output voltages stay within regulation after loss of AC.	21		ms
$T_{pwok\_holdup}$	Delay from loss of AC to de-assertion of PWOK	20		ms
$T_{pson\_on\_delay}$	Delay from PSON <sup>#</sup> active to output voltages within regulation limits.	5	400	ms
$T_{pson\_pwok}$	Delay from PSON <sup>#</sup> deactive to PWOK being de-asserted.		50	ms
$T_{pwok\_on}$	Delay from output voltages within regulation limits to PWOK asserted at turn on.	100	1000	ms
$T_{pwok\_off}$	Delay from PWOK de-asserted to 12-V output voltage dropping out of regulation limits.	1		ms
$T_{pwok\_low}$	Duration of PWOK being in the de-asserted state during an off/on cycle using AC or the PSON signal.	100		ms
$T_{sb\_vout}$	Delay from 5 VSB being in regulation to O/Ps being in regulation at AC turn on.	50	1000	ms
$T_{5VSB\_holdup}$	Time the 5 VSB output voltage stays within regulation after loss of AC.	70		ms

**Note:**

1  $T_{vout\_holdup}$  and  $T_{pwok\_holdup}$  are defined under 75% loading.



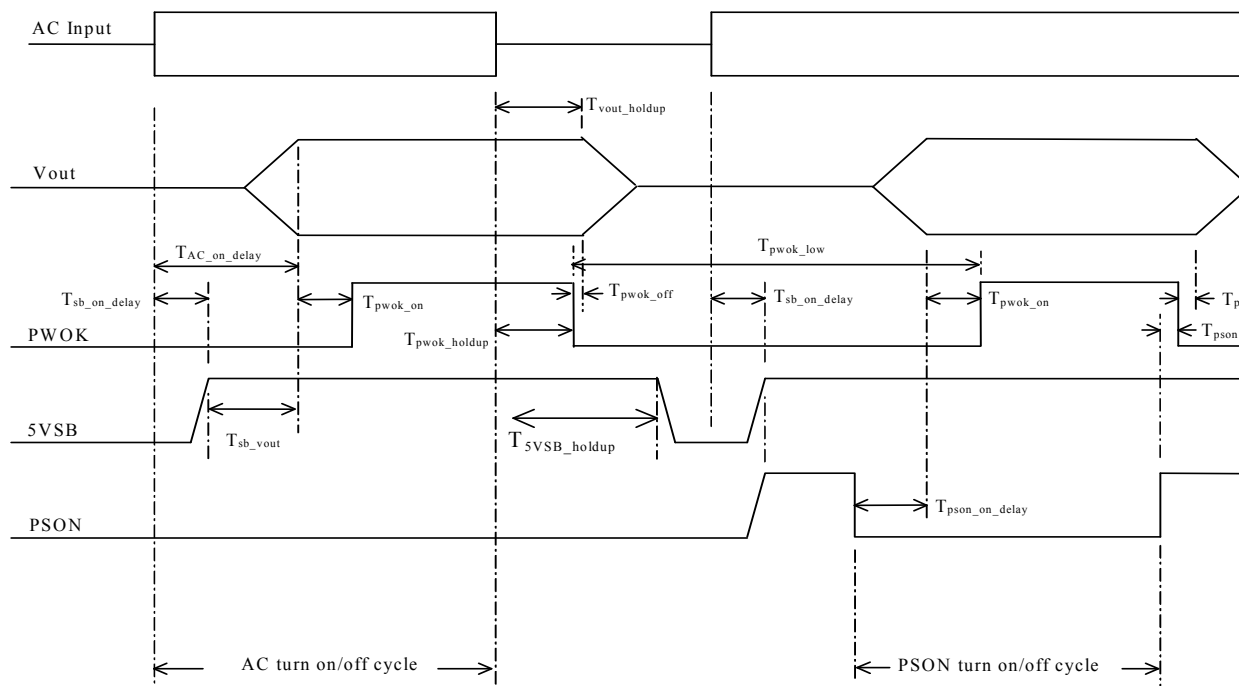

**Figure 13. Turn On/Off Timing (Power Supply Signals)**

#### 2.2.3.14 Hot Swap Requirement

Hot swapping a power supply is the process of inserting and extracting a power supply from an operating power system. During this process, the output voltages remain within the capacitive load limits. Up to two power supplies can be on a single AC line. The power supply hot swaps by the following method.

- Extraction: The AC power disconnects from the power supply as the power supply is extracted from the system. This can occur in standby mode or power-on mode.
- Insertion: The AC power connects to the power supply as the power supply is inserted into the system. The power supply powers on into either standby mode or power-on mode.

In general, a failed (off by internal latch or external control) power supply may be removed then replaced with a good power supply; however, hot swap will work with both operational as well as failed power supplies. The newly inserted power supply will go into either standby or power-on mode once inserted.

#### 2.2.3.15 Residual Voltage Immunity in Standby Mode

The power supply is immune to any residual voltage placed on its 12-V output (typically a leakage voltage through the system from standby output) up to 1000 mV. This residual voltage does not have any adverse effects on the power supply, including additional power dissipation

or over-stressing / over-heating any internal components or adversely affecting the turn-on performance (no protection circuits tripping during turn on).

While in standby mode, at no load condition, the residual voltage on the 12-V output does not exceed 100 mV.

### 2.2.3.16 Soft Starting

The power supply contains control circuits that provide monotonic soft start of its outputs without overstressing the AC line or any power supply components at any specified AC line or load conditions. There is no requirement for rise time on the 5VSB but the turn on/off is monotonic.

### 2.2.3.17 Zero Load Stability Requirements

When the power subsystem operates in a no-load condition in a 1+0 or 1+1 configuration, it does not need to meet the output regulation specification, but it must operate without any tripping of over-voltage or other fault circuitry. When the power subsystem is subsequently loaded, it must begin to regulate and source current without fault.

## 2.2.4 Protection Circuits

Protection circuits inside the power supply cause only the power supply's main outputs to shut down. If the power supply latches off due to a protection circuit tripping, an AC cycle OFF for 15 seconds and a PSON# cycle HIGH for 1 second will reset the power supply.

### 2.2.4.1 Over-current Protection (OCP)

The power supply has a current limit to prevent the +5 VSB and +12 V outputs from exceeding the values shown in the following table. If the current limits are exceeded, the power supply shuts down and latches off. The latch is cleared by toggling the PSON# signal or by an AC power interruption. The power supply is not damaged from repeated power cycling in this condition. 5 VSB is protected under over-current or shorted conditions so no damage can occur to the power supply.

**Table 41. Over-current Protection (OCP)**

Output Voltage	Over-current Protection Limits
+12V	120% min (= 58.8 A min); 140% max (= 68.6 A max)
+5VSB	120% min (= 3.6 A min); 200% max (= 6.0 A max)

### 2.2.4.2 Over-voltage Protection (OVP)

The power supply's over-voltage protection is locally sensed. The power supply will shut down and latch off after an over-voltage condition occurs. You can clear this latch by toggling the PSON# signal or by an AC power interruption. The following table contains the over-voltage limits. The values are measured at the output of the power supply's connectors. The voltage

never exceeds the maximum levels when measured at the power pins of the power supply connector during any single point of fail. The voltage will never trip any lower than the minimum levels when measured at the power pins of the power supply connector.

**Table 42. Over-voltage Protection Limits**

Output Voltage	MIN (V)	MAX (V)
+12 V	13.3	14.5
+5 VSB	5.7	6.5

### 2.2.4.3 Over-temperature Protection (OTP)

The power supply is protected against over-temperature conditions caused by loss of fan cooling, excessive ambient temperature, or excessive loading. Sensing points are placed at hot spots. In an OTP condition, the power supply shuts down. When the power supply temperature drops to within specified limits, the power supply restores power automatically, while the 5VSB always remains on. The OTP circuit has built-in hysteresis such that the power supply does not oscillate on and off due to temperature recovery conditions. The OTP trip level has a minimum of 4° Celcius of ambient temperature hysteresis.

### 2.2.5 Control and Indicator Functions

The following sections define the input and output signals from the power supply. Signals that can be defined as low true use the following convention:

signal# = low true

#### 2.2.5.1 PSON# Input Signal

The PSON# signal is required to remotely turn on/off the power supply. PSON# is an active low signal that turns on the +12V power rail. When this signal is not pulled low by the system or left open, the outputs (except for the +5VSB) turn off. This signal is pulled to a standby voltage by a pull-up resistor internal to the power supply.

**Table 43. PSON# Signal Characteristic**

Signal Type	Accepts an open collector/drain input from the system. Pull-up to VSB located in power supply.	
PSON# = Low	ON	
PSON# = High or Open	OFF	
	<b>MIN</b>	<b>MAX</b>
Logic level low (power supply ON)	0V	1.0V
Logic level high (power supply OFF)	2.0V	5.25V
Source current, Vpson = low		4mA
Power up delay: $T_{pson\_on\_delay}$	5msec	400msec
PWOK delay: $T_{pson\_pwok}$		50msec

### 2.2.5.2 PSKill

The purpose of the PSKill pin is to allow for hot swapping of the power supply. The PSKill pin on the power supply is shorter than the other signal pins. When a power supply is operating in parallel with other power supplies and then extracted from the system, the PSKill pin will quickly turn off the power supply and prevent arcing of the DC output contacts.  $T_{PSKill}$  (shown in the following table) is the minimum time delay from the PSKill pin un-mating to when the power pins un-mate. The power supply must discharge its output inductor within this time from the unmating of the PSKill pin. When the PSKill signal pin is not pulled down or left open (power supply is extracted from the system), the power supply shuts down regardless of the condition of the PSON# signal. The mating pin of this signal in the system should be tied to ground. Internal to the power supply, the PSKill pin should be connected to a standby voltage through a pull-up resistor. Upon receiving a LOW state signal at the PSKill pin, the power supply is allowed to turn on via the PSON# signal. A logic LOW on this pin by itself should not turn on the power outputs.

**Table 44. PSKILL Signal Characteristics**

Signal Type (Input Signal to Supply)	Accepts a ground input from the system. Pull-up to VSB located in the power supply.	
PSKILL = Low, PSON# = Low	ON	
PSKILL = Open, PSON# = Low or Open	OFF	
PSKILL = Low, PSON# = Open	OFF	
	<b>MIN</b>	<b>MAX</b>
Logic level low (power supply ON)	0 V	1.0 V
Logic level high (power supply OFF)	2.0 V	5.25 V
Source current, Vpskill = low		4 mA
Delay from PSKILL=High to power supply turned off ( $T_{PSKill}$ ) <sup>1</sup>		100 $\mu$ s

**Note:**

1.  $T_{PSKill}$  is the time from the PSKill signal de-asserting HIGH to the power supply's output inductor discharging.

### 2.2.5.3 PWOK (Power OK) Output Signal

PWOK is a power OK signal and is pulled HIGH by the power supply to indicate that all the outputs are within the regulation limits of the power supply. When any output voltage falls below regulation limits or when AC power has been removed for a time sufficiently long so the power supply operation is no longer guaranteed, PWOK will be de-asserted to a LOW state. The start of the PWOK delay time is inhibited as long as any power supply output is in current limit.

**Table 45. PWOK Signal Characteristics**

Signal Type	Open collector/drain output from power supply. Pull-up to VSB located in system.	
PWOK = High	Power OK	
PWOK = Low	Power Not OK	
	MIN	MAX
Logic level low voltage, $I_{\text{sink}}=4\text{mA}$	0 V	0.4 V
Logic level high voltage, $I_{\text{source}}=200\mu\text{A}$	2.4 V	5.25 V
Sink current, PWOK = low		4 mA
Source current, PWOK = high		2 mA
PWOK delay: $T_{\text{pwok\_on}}$	100 ms	1000 ms
PWOK rise and fall time		100 $\mu\text{s}$
Power down delay: $T_{\text{pwok\_off}}$	1 ms	200 ms

### 2.2.5.4 LEDs

There is a bi-color LED and a single color LED to indicate power supply status. The LED operation is defined in the following table.

**Table 46. LED Indicators**

Power Supply Condition	Status LED (AC OK / Power Supply Fail)	Power Led (Power Good)	Remarks
AC Power Off	OFF	OFF	
AC Power On in Standby Mode	Green	OFF	
AC On and All Outputs in Normal Mode	Green	Green	
Any DC Outputs Short Circuit	Green	OFF	Power Distribution Board protection only; module OK
DC Fan Not Spinning	Amber	OFF	Module protection only
OTP	Amber	Green	Send out alert signal

The LEDs are visible on the power supply's exterior face. The LEDs' location meets Electrostatic Discharge (ESD) requirements. LEDs are securely mounted in such a way that incidental pressure on the LEDs does not cause them to be displaced.

Bits allow the LED states to be forced via the SMBus. The following capabilities are required:

- Force Amber ON for failure conditions.
- No Force (LED state follows power supply present state)

The power-on default is 'No Force'. The default is restored whenever PSON transitions to assert.

## 2.2.6 PMBus Monitoring Interface

The PMBus features included in this specification are requirements for ac/dc silver box power supply for use in mainstream server systems. This specification is based on the PMBus specifications parts I and II, revision 1.2.

### 2.2.6.1 Related Documents

PMBus™ Power System Management Protocol Specification Part I – General Requirements, Transport And Electrical Interface; Revision 1.2

PMBus™ Power System Management Protocol Specification Part II – Command Language; Revision 1.2

System Management Bus (SMBus) Specification Version 2.0

### 2.2.6.2 Addressing

The power supply PMBus device address locations are shown in the following table. For redundant systems there are up to three signals to set the address location of the power supply

once it is installed in the system: Address2, Address1, and Address0. For non-redundant systems the power supply device address location should be B0h.

System addressing Address2/Address1/ Address0	0/0/0	0/0/1	0/1/0	0/1/1	1/0/0	1/0/1	1/1/0	1/1/1
PMBus device read addresses 2	B0h/B1h1	B2h/B3h	B4h/B5h	B6h/B7h	B8h/B9h	BAh/BBh	BCh/BDh	BEh/BFh

<sup>1</sup> Non-redundant power supplies use the 0/0/0 address location

<sup>2</sup> The addressing method uses the 7 MSB bits to set the address and the LSB to define whether a device is reading or writing. The addresses defined above use 8 bits including the read/write bit.

#### IPMI FRU Addressing:

If the power supply has a FRU (field replaceable unit) serial EEPROM; it should be located at the following addresses.

System addressing Address2/Address1/ Address0	0/0/0	0/0/1	0/1/0	0/1/1	1/0/0	1/0/1	1/1/0	1/1/1
FRU device addresses 2	A0h/A1h 1	A2h/A3h	A4h/A5h	A6h/A7h	A8h/A9h	AAh/ABh	ACh/ADh	Aeh/AFh

<sup>1</sup> Non-redundant power supplies use the 0/0/0 address location.

<sup>2</sup> The addressing method uses the 7 MSB bits to set the address and the LSB to define whether a device is reading or writing. The addresses defined above use 8 bits including the read/write bit.

## 2.3 600-W Power Distribution Board (PDB)

This specification defines the 570-W cage for the ERP12V 600-W 1+1 redundant power supply and for the ERP 12V 600-W 2+0 non-redundant power supply. The cage is designed to plug directly to the output connector of the power supply and contains three DC/DC power converters to produce other required voltages: +3.3VDC, +5VDC, and -12VDC along with additional 12V rail 240VA protection and a FRU EEPROM.

### 2.3.1 Mechanical Overview

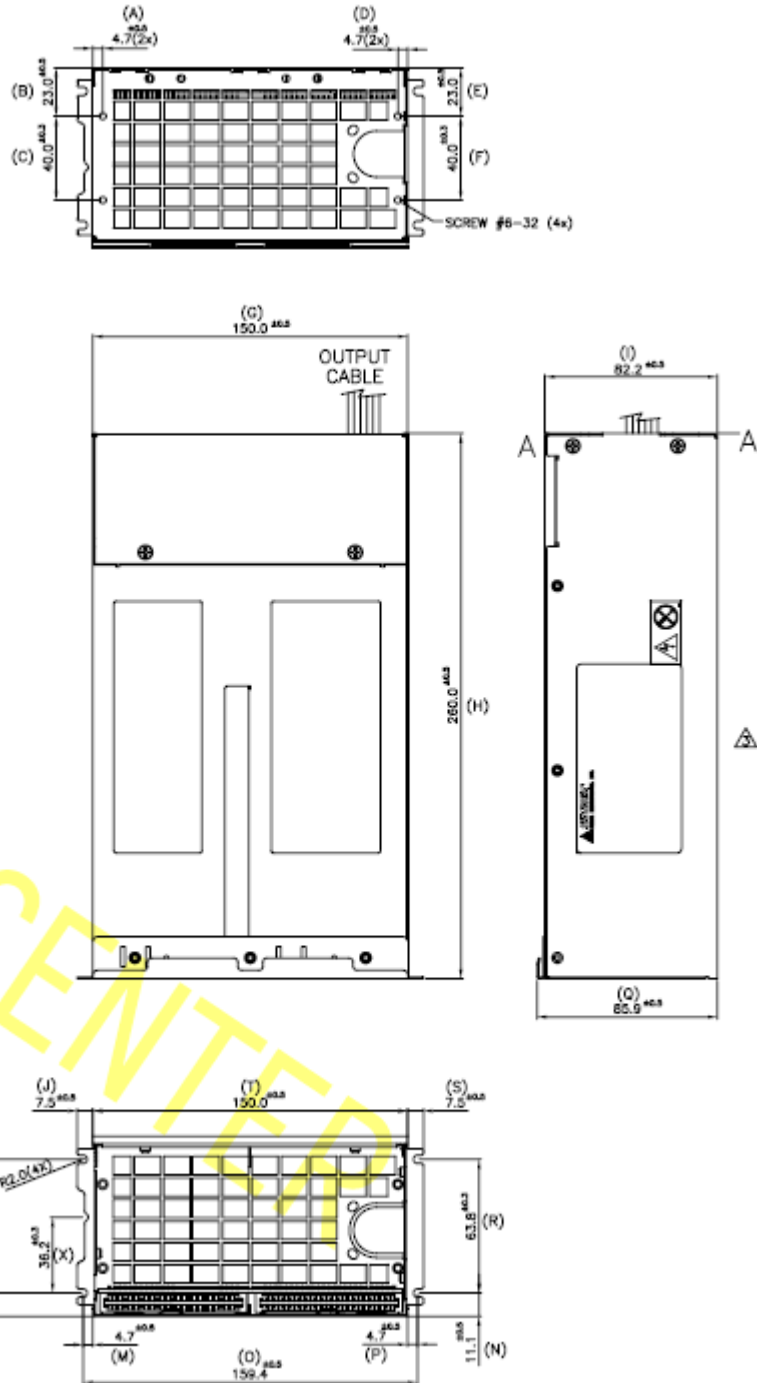



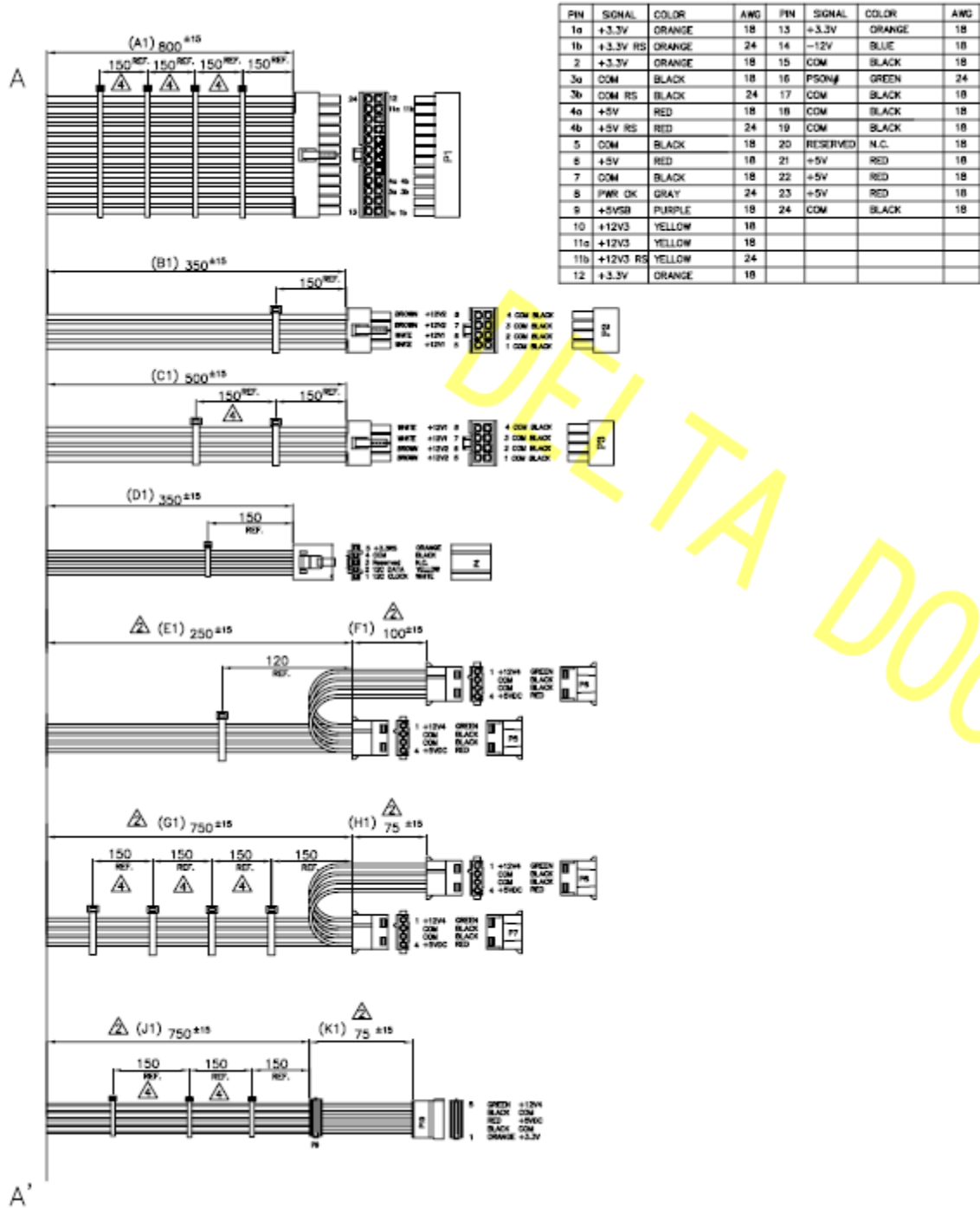

Figure 14. Mechanical Drawing for Dual (1+1 Configuration) Power Supply Enclosure

### 2.3.1.1 Airflow Requirements

There is no fan in the cage; the cage is cooled by the fan in the power supply module(s) when combined together in the system.

### 2.3.1.2 Temperature Requirements

The PDB operates within all specified limits over the  $T_{op}$  temperature range.

Table 47. Environmental Requirements

Item	Description	MIN	MAX	Units
$T_{op}$	Operating temperature range.	0	45	°C
$T_{non-op}$	Non-operating temperature range.	-40	70	°C
Altitude	Maximum operating altitude		1500	m

### 2.3.1.3 Efficiency

Each DC/DC converter shall have a **minimum** efficiency of **85%** at Max load and over +12V line voltage range and over temperature and humidity range.

### 2.3.1.4 Output Connectors

Listed or recognized component appliance wiring material (AVLV2), CN, rated min 105 degrees C, 300VDC is used for all output wiring.

Table 48. Cable Lengths

From	Length (mm)	To Connector #	Number of Pins	Description
Power Supply cover exit hole	800	P1	24	Baseboard Power Connector
Power Supply cover exit hole	350	P2	8	Processor 0 Power Connector
Power Supply cover exit hole	500	P3	8	Processor 1 Power Connector
Power Supply cover exit hole	350	P4	5	Power PSMI Connector
Power Supply cover exit hole	250	P5	4	Peripheral Power Connector
Extension	100	P6	4	Peripheral Power Connector
Power Supply cover exit hole	750	P7	4	Peripheral Power Connector
Extension	75	P8	4	Peripheral Power Connector
Power Supply cover exit hole	750	P9	5	Right-angle SATA Power Connector
Extension	75	P10	5	SATA Power connector for fixed HDD Connector

### 2.3.1.5 Baseboard Power Connector (P1)

Connector housing: 24-Pin Molex\* Mini-Fit Jr. 39-01-2245 or equivalent  
 Contact: Molex\* Mini-Fit, HCS, Female, Crimp 44476 or equivalent

**Table 49. P1 Baseboard Power Connector**

Pin	Signal	18 AWG Color	Pin	Signal	18 AWG Color
1*	+3.3VDC	Orange	13	+3.3VDC	Orange
	3.3V RS	Orange (24AWG)	14	-12VDC	Blue
2	+3.3VDC	Orange	15	COM	Black
3*	COM	Black	16	PSON#	Green (24AWG)
	COM RS	Black (24AWG)	17	COM	Black
4*	+5VDC	Red	18	COM	Black
	5V RS	Red (24AWG)	19	COM	Black
5	COM	Black	20	Reserved	N.C.
6	+5VDC	Red	21	+5VDC	Red
7	COM	Black	22	+5VDC	Red
8	PWR OK	Gray (24AWG)	23	+5VDC	Red
9	5 VSB	Purple	24	COM	Black
10	+12V3	Yellow			
11	+12V3	Yellow			
	+12V3 RS	Yellow (24AWG)			
12	+3.3VDC	Orange			

**Note:** Remote Sense wire double-crimped.

### 2.3.1.6 Processor 0 Power Connector (P2)

Connector housing: 8-Pin Molex\* 39-01-2080 or equivalent

Contact: Molex\* 44476-1111 or equivalent

**Table 50. P2 Processor 0 Power Connector**

Pin	Signal	18 AWG Color	Pin	Signal	18 AWG Color
1	COM	Black	5	+12V1	White
2	COM	Black	6	+12V1	White
3	COM	Black	7	+12V2	Brown
4	COM	Black	8	+12V2	Brown

### Processor 1 Power Connector (P3)

Connector housing: 8-Pin Molex\* 39-01-2080 or equivalent

Contact: Molex\* 44476-1111 or equivalent

**Table 51. P3 Processor 1 Power Connector**

Pin	Signal	18 AWG Color	Pin	Signal	18 AWG Color
1	COM	Black	5	+12V1	White
2	COM	Black	6	+12V1	Brown
3	COM	Black	7	+12V2	White
4	COM	Black	8	+12V2	White

### 2.3.1.7 Power Signal Connector (P4)

Connector housing: 5-Pin Molex\* 50-57-9405 or equivalent  
 Contacts: Molex\* 16-02-0087 or equivalent

**Table 52. P4 Power Signal Connector**

Pin	Signal	24 AWG Color
1	I <sup>2</sup> C Clock	White
2	I <sup>2</sup> C Data	Yellow
3	Reserved	N.C.
4	COM	Black
5	3.3 RS	Orange

### 2.3.1.8 Peripheral Power Connectors (P5, P6, P7, P8)

Connector housing: Amp\* 1-480424-0 or equivalent  
 Contact: Amp\* 61314-1 contact or equivalent

**Table 52. P5, P6, P7, and P8 Peripheral Power Connectors**

Pin	Signal	18 AWG Color
1	+12V4	Green
2	COM	Black
3	COM	Black
4	+5 VDC	Red

### 2.3.1.9 Right-angle SATA Power Connectors (P9)

Connector housing: JWT\* F6002HS0-5P-18 or equivalent

**Table 53. P9 Right-angle SATA Power Connector**

Pin	Signal	18 AWG Color
1	+3.3V	Orange
2	COM	Black
3	+5VDC	Red
4	COM	Black
5	+12V4	Green

### 2.3.1.10 SATA Power Connector (P10)

Connector housing: JWT\* A3811H00-5P or equivalent  
 Contact: JWT\* A3811TOP-0D or equivalent

**Table 54. P10 SATA Power Connector**

Pin	Signal	18 AWG Color
1	+3.3V	Orange
2	COM	Black
3	+5VDC	Red
4	COM	Black
5	+12V4	Green

## 2.3.2 DC Output Specification

### 2.3.2.1 Remote Sense

The cage 12V to 3.3V and 5V converters use remote sensing to regulate out voltage drops in the system for the +3.3V output. The remote sense output impedance to this DC/DC converter must be greater than 200Ω. This is the value of the resistor connecting the remote sense to the output voltage internal to the DC/DC converter. Remote sense must be able to regulate out of up to 300mV drop on the +3.3V and 5V outputs. Also, the power supply ground return remote sense (ReturnS) passes through the PDB and the output harness to regulate out ground drops for its +12V and 5Vsb output voltages. The power supply uses remote sense (12VRS) to regulate out drops up to the 240VA protection circuits on the PDB.

### 2.3.2.2 +12V Outputs Load Requirements

This section describes the +12V output power requirements from the cage with one or two 600-W power supplies plugged into the input of the cage. The power distribution board divides up the 12-V power from power supply modules into five separate 240VA limited channels. Channels 1 through 4 supply 12-V power directly to the end system. A channel supplies power to the 3.3V, 5V, and -12V PDB converters.

**Table 55. +12V Outputs Load Ratings**

	+12V1/2/3/4 combined output limit = 64A / 72A pk max			
	+12V1	+12V2	+12V3	+12V4
MAX Load	16A	16A	16A	16A
MIN Static / Dynamic Load	0.2A	0.2A	0.1A	0.1A
Peak load (12 seconds)	18A	18A	18A	18A

1. Peak power and current loading shall be supported for a minimum of 12 seconds.

### 2.3.2.3 DC/DC Converters Loading

The following table defines the power and current ratings for the three DC/DC converters located on the cage; each is powered from a +12V5 rail. The three converters meet both static and dynamic voltage regulation requirements for the minimum and maximum loading conditions.

---

**Note:** 3.3V/5V combined power limit: 170 W max

---

**Table 56. DC/DC Converters Load Ratings**

	+12VDC Input DC/DC Converters		
	+3.3V Converter	+5V Converter	-12V Converter
MAX Load	24.0A	30.0A	0.3A
MIN Static / Dynamic Load	0A	0A	0A

1. Maximum continuous total DC output power should not exceed 570 W.
2. Peak power and current loading shall be supported for a minimum of 12 seconds.
3. Combined 3.3V and 5V power shall not exceed 170 W.

### 2.3.2.4 DC/DC Converters Voltage Regulation

The DC/DC converters' output voltages stay within the following voltage limits when operating at steady state and dynamic loading conditions. These limits include the peak-peak ripple/noise. All outputs are measured with reference to the return remote sense signal (ReturnS). The 3.3V and 5V outputs are measured at the remote sense point; all other voltages are measured at the output harness connectors.

**Table 57. Voltage Regulation Limits**

Converter Output	Tolerance	MIN	NOM	MAX	UNITS
+ 3.3VDC	- 5% / +5%	+3.14	+3.30	+3.46	V <sub>DC</sub>
+ 5VDC	- 5% / +5%	+4.75	+5.00	+5.25	V <sub>DC</sub>
+ 12VDC (12V1/2/3/4)	- 5% / +5%	+11.40	+12.00	+12.60	V <sub>DC</sub>
- 12VDC	- 10% / +10%	-10.80	-12.00	-13.20	V <sub>DC</sub>
+ 5VSB	See Power Supply Specification; measured at the power distribution board harness connectors.				

### 2.3.2.5 DC / DC Converters Dynamic Loading

The output voltages remain within limits specified for step loading and capacitive loading as specified in the following table. The load transient repetition rate is tested between 50 Hz and 5 kHz at duty cycles ranging from 10%-90%. The load transient repetition rate is only a test specification. The  $\Delta$  step load may occur anywhere between MIN load and MAX load conditions.

**Table 58. Transient Load Requirements**

Output	Max $\Delta$ Step Load Size	Max Load Slew Rate	Test Capacitive Load
+ 3.3VDC	5.0A	0.25 A/ $\mu$ s	250 $\mu$ F
+ 5VDC	6.0A	0.25 A/ $\mu$ s	400 $\mu$ F
+12VDC (12V1/2/3/4/5)	See the Power Supply specification for details.		
- 12VDC	<i>Not rated</i>	<i>Not rated</i>	$\mu$ F
+5VSB	See the the Power Supply specification for details.		

### 2.3.2.6 DC / DC Converter Capacitive Loading

All outputs of the DC / DC converter are stable and meet all requirements with the following capacitive loading ranges.

**Table 59. Capacitive Loading Conditions**

Converter Output	MIN	MAX	Units
+3.3VDC	250	6,800	μF
+5VDC	400	4,700	μF
-12VDC	1	350	μF

**Note:** Refer to the Power Supply specification for the equivalent data on +12V and +5VSB output.

### 2.3.2.7 DC/DC Converters Closed Loop Stability

Each DC/DC converter is unconditionally stable under all line/load/transient load conditions, including capacitive load ranges. A minimum of 45 degrees phase margin and –10dB-gain margin is required.

### 2.3.2.8 Common Mode Noise

The Common Mode Noise on any output does not exceed 350 mV peak-peak over the frequency band of 10 Hz to 30 MHz.

### 2.3.2.9 DC/DC Converters Ripple/Noise

The maximum allowed ripple/noise output of each DC/DC Converter is defined in the following table. This is measured over a bandwidth of 0Hz to 20MHz at the PDB output connectors. A 10μF tantalum capacitor in parallel with a 0.1μF ceramic capacitor is placed at the point of measurement.

**Table 60. Ripple and Noise**

+3.3V Output	+5V Output	-12V Output
50mVp-p	50mVp-p	120mVp-p

**Note:** Refer to the Power Supply specification for the equivalent data on +12V and +5VSB output.

### 2.3.2.10 Fan Operation in Standby Mode

The fans on the power distribution board continue to operate at their lowest speed (5V) when in standby mode.

### 2.3.2.11 Timing Requirements

The timing requirements for the power supply/PDB combination are as follows. The output voltages must rise from 10% to within regulation limits ( $T_{vout\_rise}$ ) within 5 to 70 ms, except for 5VSB, which is allowed to rise from 1.0 to 25 ms. The +3.3V, +5V, and +12V output voltages start to rise at approximately the same time. All outputs rise monotonically. The +5V output is greater than the +3.3V output during any point of the voltage rise. The +5V output is never greater than the +3.3V output by more than 2.25V. Each output voltage reaches regulation within 50ms ( $T_{vout\_on}$ ) of each other during turn on of the power supply. Each output voltage falls out of regulation within 400 msec ( $T_{vout\_off}$ ) of each other during turn off. The following figure shows the timing requirements for the power supply being turned on and off via the AC input, with PSON held low and the PSON signal, with the AC input applied.

**Table 61. Output Voltage Timing**

Item	Description	Minimum	Maximum	Units
$T_{vout\_rise}$	Output voltage rise time from each main output.	5.0*	70*	msec
$T_{vout\_on}$	All main outputs must be within regulation of each other within this time.		50	msec
$T_{vout\_off}$	All main outputs must leave regulation within this time.		400	msec

\* The 5VSB output voltage rise time shall be from 1.0 ms to 25.0 ms.

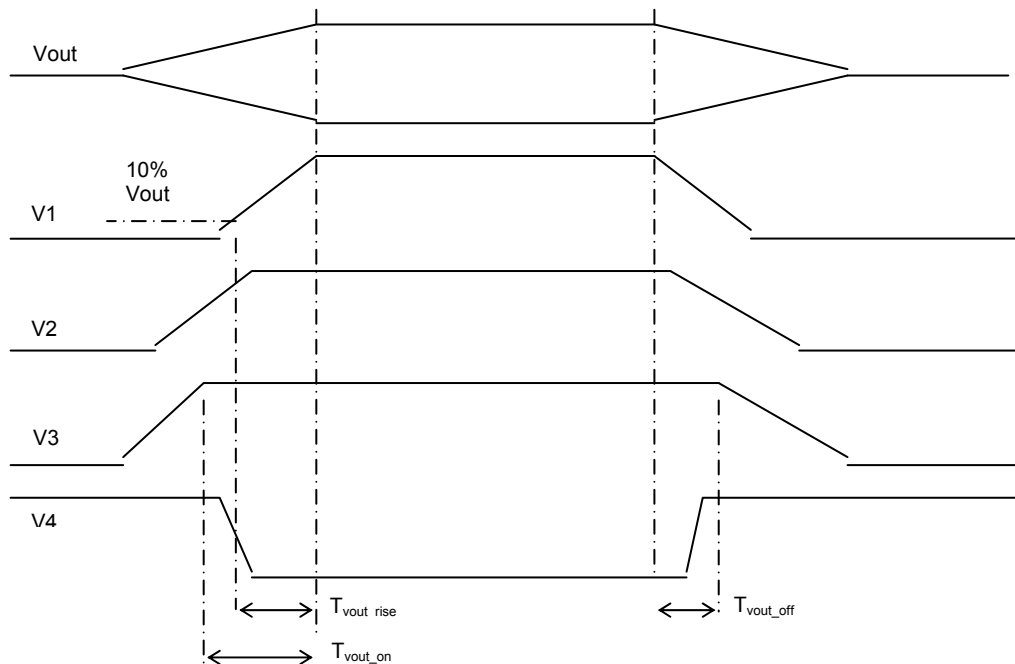
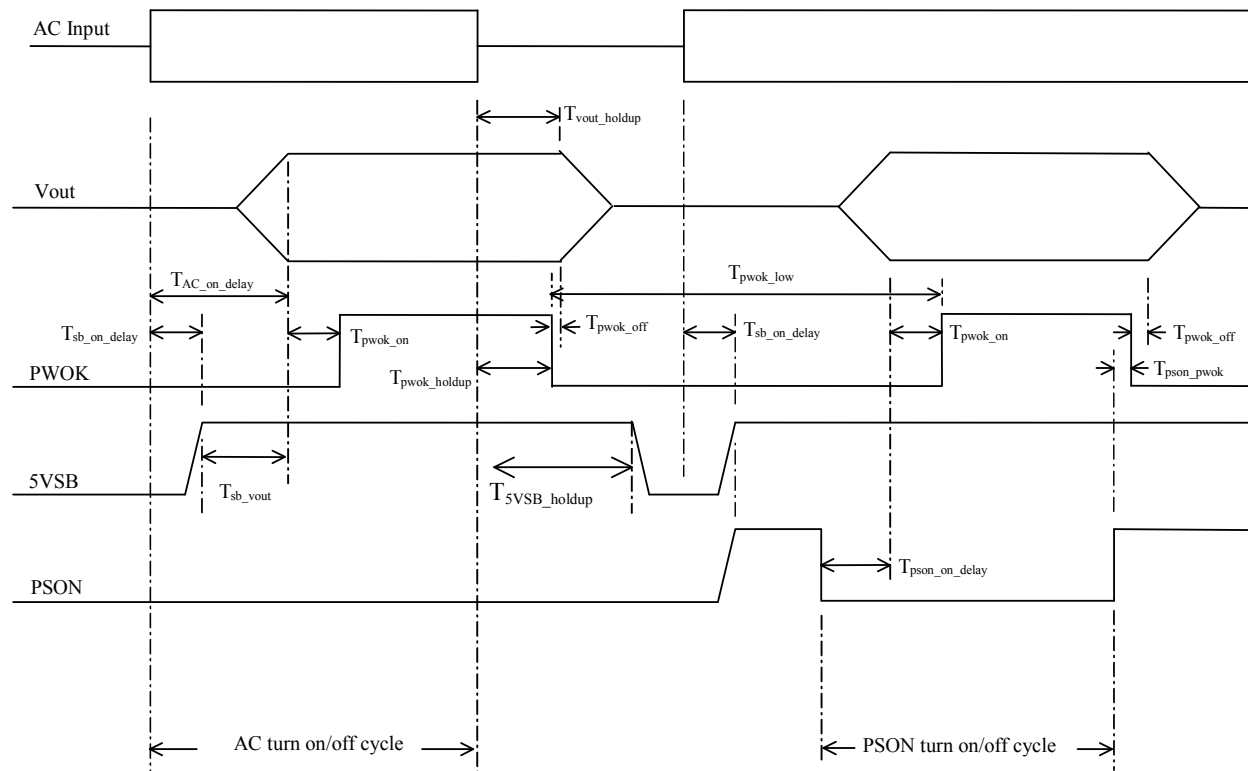

**Figure 15. Output Voltage Timing**



**Table 62. Turn On / Off Timing**

Item	Description	Loading	Minimum	Maximum	Units
$T_{sb\_on\_delay}$	Delay from AC being applied to 5VSB being within regulation.			1500	ms
$T_{ac\_on\_delay}$	Delay from AC being applied to all output voltages being within regulation.			2500	ms
$T_{vout\_holdup}$	Time all output voltages stay within regulation after loss of AC.	75%	21		ms
$T_{pwok\_holdup}$	Delay from loss of AC to de-assertion of PWOK	75%	20		ms
$T_{pson\_on\_delay}$	Delay from PSON# active to output voltages within regulation limits.		5	400	ms
$T_{pson\_pwok}$	Delay from PSON# deactive to PWOK being de-asserted.			50	ms
$T_{pwok\_on}$	Delay from output voltages within regulation limits to PWOK asserted at turn on.		100	500	ms
$T_{pwok\_off}$	Delay from PWOK de-asserted to output voltages (3.3V, 5V, 12V, -12V) dropping out of regulation limits.		1		ms
$T_{pwok\_low}$	Duration of PWOK being in the de-asserted state during an off/on cycle using AC or the PSON signal.		100		ms
$T_{sb\_vout}$	Delay from 5VSB being in regulation to O/Ps being in regulation at AC turn on.		50	1000	ms
$T_{5VSB\_holdup}$	Time the 5VSB output voltage stays within regulation after loss of AC.		70		ms



**Figure 16. Turn On/Off Timing (Power Supply Signals)**

### 2.3.2.12 Residual Voltage Immunity in Standby Mode

Each DC/DC converter is immune to any residual voltage placed on its respective output (typically a leakage voltage through the system from standby output) up to 500mV. There is no additional heat generated, nor is there any stress of any internal components with this voltage applied to any individual output, or all outputs simultaneously. Residual voltage also does not trip the power supply protection circuits during turn on.

Residual voltage at the power supply outputs for no-load condition does not exceed 100mV when AC voltage is applied and the PSON# signal is de-asserted.

### 2.3.2.13 Soft Start Requirements

The power supply contains a control circuit which provides monotonic soft start for its outputs without overstressing the AC line or any power supply components at any specified AC line or load conditions. There is no requirement for rise time on the 5VSB, but the turn on/off is monotonic.

## 2.3.3 Protection Circuits

Protection circuits inside the cage (and the power supply) cause the power supply's main +12V output to shut down, thereby forcing the remaining three outputs on the cage to shut down. If the power supply latches off due to a protection circuit tripping, an AC cycle OFF for 15 sec min and a PSON# cycle HIGH for 1 second will reset the power supply and the PDB.

### 2.3.3.1 Over-current Protection (OCP) / 240VA Protection

Each DC/DC converter output on the cage has individual OCP circuits. The PS+cage combination will shut down and latch off after an over-current condition occurs. This latch is cleared by toggling the PSON# signal or by an AC power interruption. The values are measured at the PDB harness connectors. The DC/DC converters are not damaged from repeated power cycling in this condition. The +12V output from the power supply is divided on the PDB into 5 channels and each channel is limited to 240VA of power except for +12V5 (+12V5 is not user accessible). Current sensors and limit circuits are available to shut down the entire PS+PDB combination if the limit is exceeded. The over-current limits are listed in the following table.

**Table 63. Over-current Protection Limits / 240VA Protection**

Output Voltage	MIN OCP Trip Limits	MAX OCP Trip Limits
+3.3V	110% min (= 26.4A min)	150% max (= 36A max)
+5V	110% min (= 33A min)	150% max (= 45A max)
-12V	0.625A	2.0A
+12V1	18A	20Amax
+12V2	18A	20Amax
Output Voltage	MIN OCP Trip Limits	MAX OCP Trip Limits
+12V3	18A	20A max
+12V4	18A	20A max
+5VSB	See the Power Supply specification for details.	

### 2.3.3.2 Over-voltage Protection (OVP)

Each DC/DC converter output on the cage has individual OVP circuits built in and is locally sensed. The PS+cage combination will shut down and latch off after an over-voltage condition occurs. This latch can be cleared by toggling the PSON# signal or by an AC power interruption.

The following table defines the over-voltage limits. The values are measured at the cage harness connectors. The voltage does not exceed the maximum levels when measured at the power pins of the output harness connector during any single point of fail. The voltage does not trip any lower than the minimum levels when measured at the power pins of the cage connector.

**Table 64. Over-voltage Protection (OVP) Limits**

Output Voltage	OVP MIN (V)	OVP MAX (V)
+3.3V	3.9	4.5
+5V	5.7	6.5
-12V	-13.3	-14.5
+12V1/2/3/4	See Power Supply specification.	
+5vsb	See Power Supply specification.	

### 2.3.3.3 Over Temperature Protection (OTP)

There is not a requirement of thermal sensor located on the cage and have OTP function itself. If there is no OTP function build in the cage, the cage should be protected by the OTP function in the module when over heated with no unrecoverable damage.

## 2.3.4 Control and Indicator Functions (Hard-wired)

The following sections define the input and output signals from the power distribution board.

Signals that can be defined as low true use the following convention:

*signal#* = low true

### 2.3.4.1 PSON# Input and Output Signals

The PSON# signal is required to remotely turn on/off the power supply. PSON# is an active low signal that turns on the +3.3V, +5V, +12V, and -12V power rails. When this signal is not pulled low by the system, or left open, the outputs (except for the +5VSB) turn off. This signal is pulled to a standby voltage by a pull-up resistor internal to the power supply.

**Table 65. PSON# Signal Characteristics**

Signal Type	Accepts an open collector/drain input from the system. Pull-up to VSB located in power supply.
-------------	--

Signal Type	Accepts an open collector/drain input from the system. Pull-up to VSB located in power supply.	
PSON# = Low	ON	
PSON# = High or Open	OFF	
	<b>MIN</b>	<b>MAX</b>
Logic level low (power supply ON)	0V	1.0V
Logic level high (power supply OFF)	2.0V	5.25V
Source current, Vpson = low		4mA
Power up delay: $T_{pson\_on\_delay}$	5msec	400msec
PWOK delay: $T_{pson\_pwok}$		50msec

### 2.3.4.2 PSKILL

The purpose of the PSkill pin is to allow for hot swapping of the power supply. The mating pin of this signal on the cage input connector is tied to ground, and its resistance is less than 5 ohms.

### 2.3.4.3 PWOK (Power OK) Input and Output Signals

PWOK is a power OK signal and will be pulled HIGH by the power supply to indicate that all the outputs are within the regulation limits of the power supply. When any output voltage falls below regulation limits, or when AC power has been removed for a time sufficiently long so that power supply operation is no longer guaranteed, PWOK will be de-asserted to a LOW state. The start of the PWOK delay time is inhibited as long as any power supply output is within current limit.

**Table 66. PWOK Signal Characteristics**

Signal Type	Open collector/drain output from power supply. Pull-up to VSB located in system.	
PWOK = High	Power OK	
PWOK = Low	Power Not OK	
	<b>MIN</b>	<b>MAX</b>
Logic level low voltage, Isink=4mA	0V	0.4V
Logic level high voltage, Isource=200µA	2.4V	5.25V
Sink current, PWOK = low		4mA
Source current, PWOK = high		2mA
PWOK delay: $T_{pwok\_on}$	100ms	1000ms
PWOK rise and fall time		100µsec
Power down delay: $T_{pwok\_off}$	1ms	200msec

### 2.3.4.4 SMBAlert#

The SMBAlert# signal indicates that the power supply is experiencing a problem that the user should investigate. The signal may be asserted due to critical events or warning events.

The SMBAlert# signal will be asserted whenever there is at least one event condition in the power supply or cage.

The SMBAlert# signal will automatically be cleared when the cause of the event is no longer present.

**Table 67. SMBAlert# Signal Characteristics**

Signal Type (Active Low)	Open collector / drain output from power supply. Pull-up to VSB located in system.	
Alert# = High	OK	
Alert# = Low	Power Alert to system	
	<b>MIN</b>	<b>MAX</b>
Logic level low voltage, Isink=4 mA	0 V	0.4 V
Logic level high voltage, Isink=50 µA		5.25 V
Sink current, Alert# = low		4 mA
Sink current, Alert# = high		50 µA
Alert# rise and fall time		100 µs

## 2.3.5 PMBus

The PMBus features included in this specification are requirements for ac/dc silver box power supply for use in mainstream server systems. This specification is based on the PMBus specifications parts I and II, revision 1.2.

### 2.3.5.1 Related Documents

PMBus™ Power System Management Protocol Specification Part I – General Requirements, Transport And Electrical Interface; Revision 1.2

PMBus™ Power System Management Protocol Specification Part II – Command Language; Revision 1.2

System Management Bus (SMBus) Specification Version 2.0

### 2.3.5.2 Addressing

The power supply PMBus device address locations are shown below. For redundant systems there are up to three signals to set the address location of the power supply once it is installed in the system; Address2, Address1, Address0. For non-redundant systems the power supply device address location should be B0h.

System addressing Address2/Address1/ Address0	0/0/0	0/0/1	0/1/0	0/1/1	1/0/0	1/0/1	1/1/0	1/1/1
PMBus device read addresses 2	B0h/B1h1	B2h/B3h	B4h/B5h	B6h/B7h	B8h/B9h	BAh/BBh	BCh/BDh	BEh/BFh

<sup>1</sup> Non-redundant power supplies will use the 0/0/0 address location

<sup>2</sup> The addressing method uses the 7 MSB bits to set the address and the LSB to define whether a device is reading or writing. The addresses defined above use 8 bits including the read/write bit.

## IPMI FRU Addressing

If the power supply has a FRU (field replaceable unit) serial EEPROM; it shall be located at the following addresses.

System addressing Address2/Address1/ Address0	0/0/0	0/0/1	0/1/0	0/1/1	1/0/0	1/0/1	1/1/0	1/1/1
FRU device addresses 2	A0h/A1h 1	A2h/A3h	A4h/A5h	A6h/A7h	A8h/A9h	AAh/ABh	ACh/ADh	Aeh/AFh

<sup>1</sup> Non-redundant power supplies will use the 0/0/0 address location.

<sup>2</sup> The addressing method uses the 7 MSB bits to set the address and the LSB to define whether a device is reading or writing. The addresses defined above use 8 bits including the read/write bit.

## 2.4 1000-W Power Supply

The 1000-W specification defines a non-redundant power supply that supports entry server systems. This 1000-W power supply has 8 outputs: 3.3V, 5V, 12V1, 12V2, 12V3, 12V4, -12V and 5VSB. The power supply contains a single 80-mm fan for cooling the power supply and part of the system.

### 2.4.1 Mechanical Overview

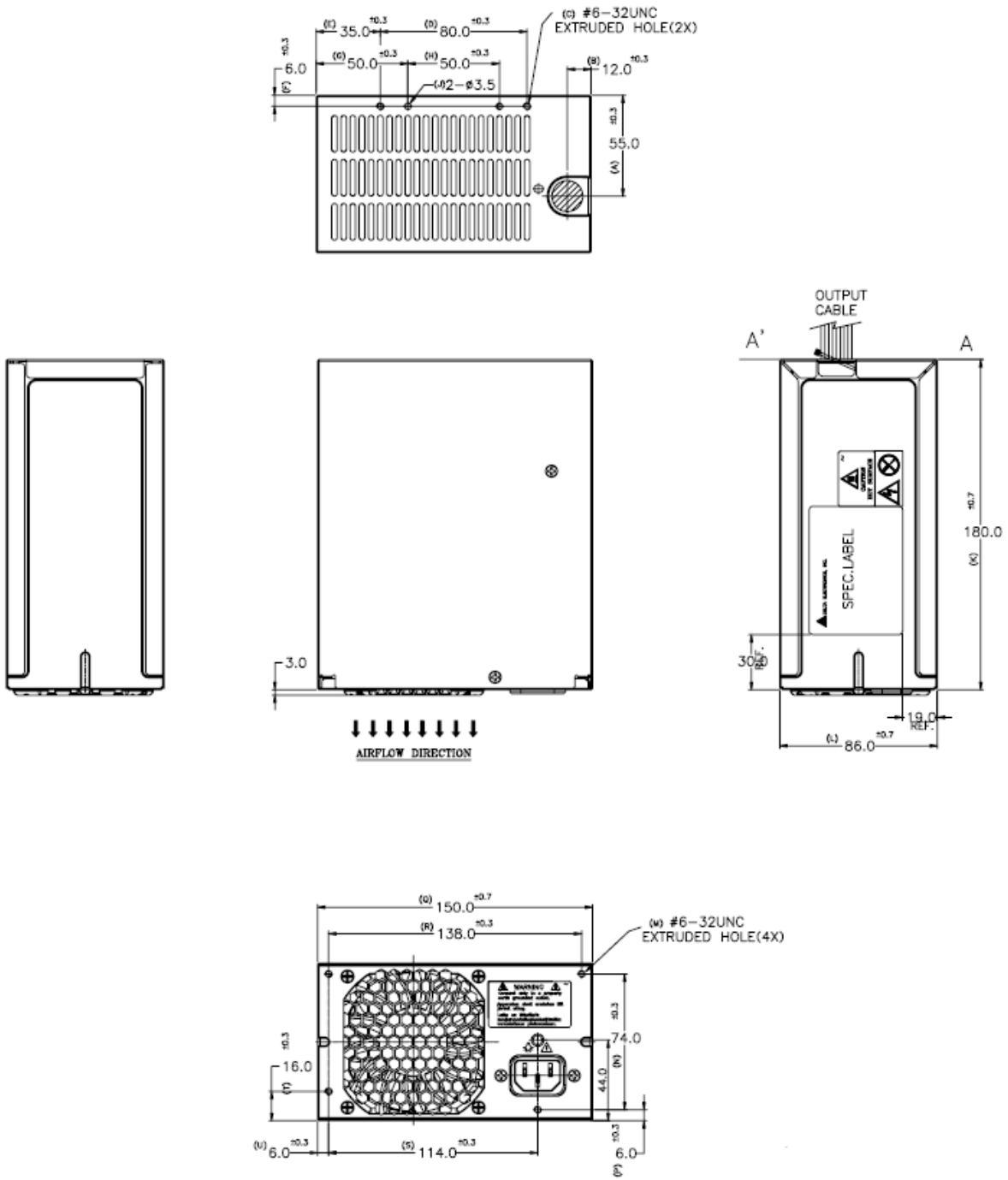

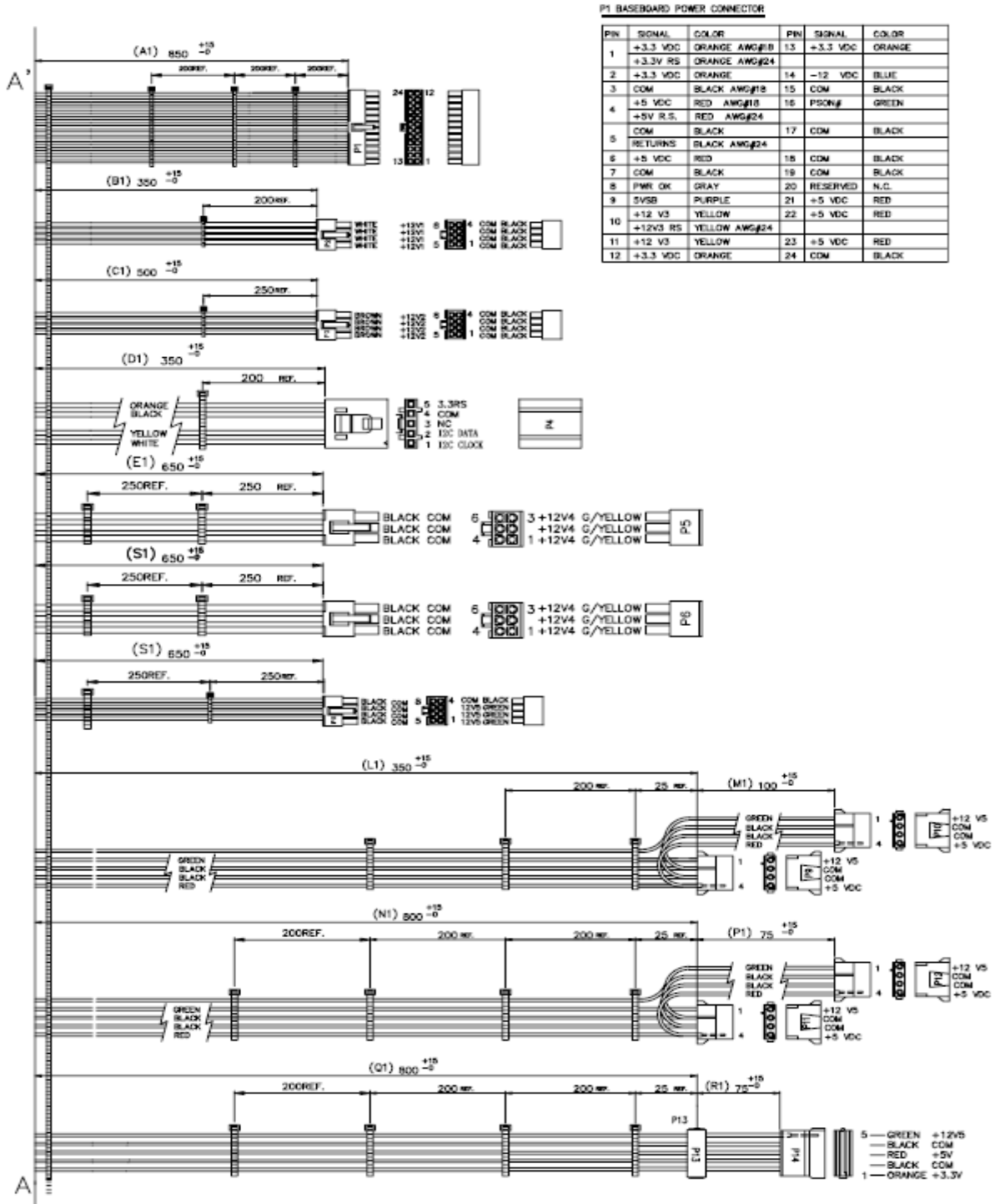

Figure 17. Mechanical Drawing of the 1000-W Power Supply Enclosure



## 2.4.2 Airflow Requirements

The power supply incorporates one 80-mm fan for self-cooling and system cooling. The fan provides no less than 14 CFM airflow through the power supply when installed in the system. The cooling air enters the power module from the non-AC side.

## 2.4.3 Acoustic Requirements

The declared sound power level of the power supply assembly does not exceed the levels specified in the following table.

**Table 68. Sound Power Requirement**

Operating Conditions	Inlet Temperature Condition	% of Maximum Loading Condition	LwAd (BA)
Maximum	45°C	100%	6.5
Operating	40°C	60%	4.7
Idle	35°C	40%	4.0

The declared sound power level is measured according to ECMA 74 and reported according to ECMA 109. The fan RPM settings for the two operating conditions are determined through thermal analysis and/or testing prior to the sound power level measurement. To measure the power supply assembly sound power levels corresponding to the two operating conditions, the fan in the power supply assembly is powered externally to the two RPM settings. The 45° Celcius inlet temperature is derived based on standard system ambient temperature assumptions (25° Celcius and 35° Celcius), typical temperature rise within the system, and thermal impact of fan speed control.

Pure Tones: The power supply assembly does not produce any prominent discrete tones, as determined according to ECMA 74, Annex D.

## 2.4.4 Temperature Requirements

The power supply operates within all specified limits over the  $T_{op}$  temperature range. All airflow passes through the power supply and not over the exterior surfaces of the power supply.

**Table 69. Thermal Requirements**

Item	Description	MIN	MAX	Units
$T_{op}$	Operating temperature range.	0	45	°C
$T_{non-op}$	Non-operating temperature range.	-40	70	°C
Item	Description	MIN	MAX	Units
Altitude	Maximum operating altitude		1500	m

The power supply meets UL enclosure requirements for temperature rise limits. All sides of the power supply, with exception of the air exhaust side, are classified as “Handle, knobs, grips, etc., held for short periods of time only.”

### 2.4.4.1 AC Input Connector

The AC input connector is an IEC 320 C-14 power inlet. This inlet is rated for 15A/250VAC.

### 2.4.4.2 LED Marking and Identification

The LED is green or amber when lit. The LED is labeled with the two symbols as illustrated:

**Power Symbol**

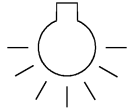

**Fail Symbol**



**Figure 18. LED Markings**

## 2.4.5 AC Input Voltage Requirements

### 2.4.5.1 AC Input Voltage Specification

The power supply operates within all specified limits over the input voltage range shown in the following table. Harmonic distortion of up to 10% of the rated line voltage must not cause the power supply to go out of specified limits. The power supply does power off if the AC input is less than 75VAC +/-5VAC range. The power supply starts up if the AC input is greater than 85VAC +/-4VAC. Application of an input voltage below 85VAC does not cause damage to the power supply, including a fuse blow.

**Table 70. AC Input Rating**

Parameter	MIN	Rated	V <sub>MAX</sub>	I <sub>MAX</sub>	Start up VAC	Power Off VAC
Voltage (110)	90 V <sub>rms</sub>	100-127 V <sub>rms</sub>	140 V <sub>rms</sub>	15 A <sup>1,3</sup>	85VAC +/-4VAC	75VAC +/-5VAC
Voltage (220)	180 V <sub>rms</sub>	200-240 V <sub>rms</sub>	264 V <sub>rms</sub>	7 A <sup>2,3</sup>		

Parameter	MIN	Rated	V <sub>MAX</sub>	I <sub>MAX</sub>	Start up VAC	Power Off VAC
Frequency	47 Hz	50/60	63 Hz			

1. Maximum input current at low input voltage range is measured at 90VAC, at max load.
2. Maximum input current at high input voltage range is measured at 180VAC, at max load.
3. This requirement is not used for determining agency input current markings.

### 2.4.5.2 AC Line Transient Specification

AC line transient conditions are defined as “sag” and “surge” conditions. “Sag” conditions are also commonly referred to as “brownout,” and are defined as AC line voltage drops below nominal voltage conditions. “Surge” is defined as AC line voltage rises above nominal voltage conditions.

The power supply meets requirements under the following AC line sag and surge conditions.

**Table 71. AC Line Sag Transient Performance**

Duration	Sag	Operating AC Voltage	Line Frequency	Loading	Performance Criteria
Continuous	10%	Nominal AC Voltage ranges	50/60Hz	100%	No loss of function or performance
0 to 1 AC cycle	100%	Nominal AC Voltage ranges	50/60Hz	60%	No loss of function or performance
> 1 AC cycle	> 10%	Nominal AC Voltage ranges	50/60Hz	100%	Loss of function acceptable, self recoverable

**Table 72. AC Line Surge Transient Performance**

Duration	Surge	Operating AC Voltage	Line Frequency	Performance Criteria
Continuous	10%	Nominal AC Voltages	50/60Hz	No loss of function or performance
0 to ½ AC cycle	30%	Mid-point of nominal AC Voltages	50/60Hz	No loss of function or performance

### 2.4.5.3 Susceptibility Requirements

The power supply meets the following electrical immunity requirements when connected to a cage with an external EMI filter that meets the criteria defined in the SSI document EPS Power Supply Specification.

**Table 73. Performance Criteria**

Level	Description
A	The apparatus shall continue to operate as intended. No degradation of performance.
B	The apparatus shall continue to operate as intended. No degradation of performance beyond spec limits.
C	Temporary loss of function is allowed provided the function is self-recoverable or can be restored by the operation of the controls.

#### 2.4.5.3.1 Electrostatic Discharge Susceptibility

The power supply complies with the limits defined in EN 55024: 1998 using the IEC 61000-4-2:1995 test standard and performance criteria B defined in Annex B of CISPR 24.

#### 2.4.5.3.2 Fast Transient/Burst

The power supply complies with the limits defined in EN55024: 1998 using the IEC 61000-4-4:1995 test standard and performance criteria B defined in Annex B of CISPR 24.

### 2.4.5.3.3 *Radiated Immunity*

The power supply complies with the limits defined in EN55024: 1998 using the IEC 61000-4-3:1995 test standard and performance criteria A defined in Annex B of CISPR 24.

### 2.4.5.3.4 *Surge Immunity*

The power supply is tested with the system for immunity to AC Ringwave and AC Unidirectional wave, both up to 2kV, per EN 55024:1998, EN 61000-4-5:1995 and ANSI C62.45: 1992.

The pass criteria include: no unsafe operation is allowed under any condition; all power supply output voltage levels must stay within proper specification levels; no change in operating state or loss of data during and after the test profile; no component damage under any condition.

The power supply complies with the limits defined in EN55024: 1998 using the IEC 61000-4-5:1995 test standard and performance criteria B defined in Annex B of CISPR 24.

### 2.4.5.4 *AC Line Fast Transient (EFT) Specification*

The power supply meets the EN61000-4-5 directive and any additional requirements in IEC1000-4-5: 1995 and the Level 3 requirements for surge-withstand capability, with the following conditions and exceptions:

- These input transients do not cause any out-of-regulation conditions, such as overshoot and undershoot, nor do they cause any nuisance trips of any of the power supply protection circuits.
- The surge-withstand test must not produce damage to the power supply.
- The supply meets surge-withstand conditions under maximum and minimum DC-output load conditions.

### 2.4.5.5 *AC Line Dropout / Holdup*

**Table 74. AC Line Dropout / Holdup**

Output Wattage	Loading	Holdup time
1000W	75%	20 ms

An AC line dropout is defined to be when the AC input drops to 0VAC at any phase of the AC line for any length of time. During an AC dropout, the power supply meets dynamic voltage regulation requirements. An AC line dropout of any duration does not cause any tripping of control signals or protection circuits. If the AC dropout lasts longer than the hold-up time, the power recovers and meets all turn-on requirements. The power supply meets the AC dropout requirement over rated AC voltages and frequencies. A dropout of the AC line for any duration does not cause damage to the power supply.

#### **2.4.5.5.1 AC Line 5VSB Holdup**

The 5VSB output voltage stays in regulation under its full load (static or dynamic) during an AC dropout of 70ms min (=5VSB holdup time) whether the power supply is in the ON or OFF state (PSON asserted or de-asserted).

#### **2.4.5.6 Power Recovery**

The power supply recovers automatically after an AC power failure. AC power failure is defined to be any loss of AC power that exceeds the dropout criteria.

##### **2.4.5.6.1 Voltage Brownout**

The power supply complies with the limits defined in EN55024: 1998 using the IEC 61000-4-11:1995 test standard and performance criteria C defined in Annex B of CISPR 24.

In addition, the power supply meets the following Intel Requirement:

- A continuous input voltage below the nominal input range shall not damage the power supply or cause overstress to any power supply component. The power supply must be able to return to normal power up state after a brownout condition. Maximum input current under a continuous brownout shall not blow the fuse. The power supply should tolerate a 3min ramp from 90VAC voltage to 0VAC after the components have reached a steady state condition.

##### **2.4.5.6.2 Voltage Interruptions**

The power supply complies with the limits defined in EN55024: 1998 using the IEC 61000-4-11:1995 test standard and performance criteria C defined in Annex B of CISPR 24.

#### **2.4.5.7 AC In-rush**

AC line in-rush current does not exceed 50A peak, cold start at 20 degrees C, and no component is damaged at hot start for up to one-quarter of the AC cycle, after which, the input current is no more than the specified maximum input current listed in Table 70. The peak in-rush current is less than the ratings of its critical components (including input fuse, bulk rectifiers, and surge limiting device).

The power supply meets the in-rush requirements for any rated AC voltage during turn on at any phase of AC voltage or during a single cycle AC dropout condition, as well as upon recovery after AC dropout of any duration, and over the specified temperature range ( $T_{op}$ ).

#### **2.4.5.8 AC Line Isolation Requirements**

The power supply meets all safety agency requirements for dielectric strength. Transformers' isolation between primary and secondary windings complies with the 3000Vac (4242Vdc) dielectric strength criteria. In addition, the insulation system complies with reinforced insulation per safety standard IEC 950. Separation between the primary and secondary circuits, and primary to ground circuits, complies with the IEC 950 spacing requirements.

### 2.4.5.9 AC Line Leakage Current

The maximum leakage current to ground for each power supply is 3.5mA when tested at 240VAC.

### 2.4.5.10 AC Line Fuse

The power supply has one line fused in the single line fuse on the Line (Hot) wire of the AC input. The line fusing is acceptable for all safety agency requirements. The input fuse is a slow blow type. AC in-rush current does not cause the AC line fuse to blow under any conditions. All protection circuits in the power supply do not cause the AC fuse to blow unless a component in the power supply has failed. This includes DC output load short conditions.

### 2.4.5.11 Power Factor Correction

The power supply incorporates a power factor correction circuit.

The power supply is tested as described in EN 61000-3-2: Electromagnetic Compatibility (EMC Part 3: Limits – Section 2: “Limits for harmonic current emissions,” and meets the harmonic current emissions limits specified for ITE equipment.

The power supply is tested as described in JEIDA MITI Guideline for Suppression of High Harmonics in Appliances and General-Use Equipment, and meets the harmonic current emissions limits specified for ITE equipment.

### 2.4.5.12 Efficiency

The following table provides the required minimum efficiency level at various loading conditions. These efficiency levels are provided at three different load levels: 100%, 50% and 20%. Efficiency is tested over an AC input voltage range of 115VAC to 220VAC.

**Table 75. Efficiency**

Loading	100% of Maximum	50% of Maximum	20% of Maximum
Recommended Efficiency	80%	80%	80%

## 2.4.6 DC Output Specification

**Table 76. Cable Lengths**

From	Length (mm)	To Connector #	Number of Pins	Description
Power Supply cover exit hole	850	P1	24	Baseboard Power Connector
Power Supply cover exit hole	350	P2	8	Processor 1 Power Connector
Power Supply cover exit hole	500	P3	8	Processor 2 Power Connector
Power Supply cover exit hole	350	P4	5	Power PSMI Connector
Power Supply cover exit hole	650	P5	6	PCIe Graphics card Power Connector
Power Supply cover exit hole	650	P6	6	PCIe Graphics card Power Connector
Power Supply cover exit hole	350	P9	4	Peripheral Power Connector
Extension	100	P10	4	Peripheral Power Connector
Power Supply cover exit hole	800	P11	4	Peripheral Power Connector
Extension	75	P12	4	Right-angle SATA Power Connector
Power Supply cover exit hole	800	P13	5	Right Angel SATA Power Connector
Extension	75	P14	5	SATA Power Signal Connector

## 2.4.7 Power Connectors

### 2.4.7.1 Baseboard Power Connector (P1)

Connector housing: 24-pin Molex\* Mini-Fit Jr. 39-01-2245 or equivalent  
 Contact: Molex\* Mini-Fit, HCS, Female, Crimp 44476 or equivalent

**Table 77. P1 Baseboard Power Connector**

Pin	Signal	18 AWG Color	Pin	Signal	18 AWG Color
1*	+3.3 VDC	Orange	13	+3.3 VDC*	Orange
	3.3V RS	Orange (24AWG)	14	-12 VDC	Blue
2	+3.3 VDC	Orange	15	COM	Black
3*	COM	Black	16	PSON#	Green
4*	+5 VDC	Red	17	COM	Black
	5V RS	Red (24AWG)	18	COM	Black
5	COM	Black	19	COM	Black
6	+5 VDC	Red	20	Reserved	N.C.
7	COM	Black	21	+5 VDC	Red

Pin	Signal	18 AWG Color	Pin	Signal	18 AWG Color
8	PWR OK	Gray	22	+5 VDC	Red
9	5VSB	Purple	23	+5 VDC	Red
10	+12V3	Yellow	24	COM	Black
	+12V3 RS	Yellow (24AWG)			
11	+12V3	Yellow			
12	+3.3 VDC	Orange			

**Notes:**

- 5V Remote Sense Double Crimped into pin 4.
- 3.3V Locate Sense Double Crimped into pin 2.

**2.4.7.2 Processor 1 Power Connector (P2)**

Connector housing: 8-pin Molex\* 39-01-2080 or equivalent

Contact: Molex\* 39-00-0059 or equivalent

**Table 78. P2 Processor 1 Power Connector**

Pin	Signal	18 AWG Color	Pin	Signal	18 AWG Color
1	COM	Black	5	+12V1	White
2	COM	Black	6	+12V1	White
3	COM	Black	7	+12V1	White
4	COM	Black	8	+12V1	White

**2.4.7.3 Processor 2 Power Connector (P3)**

Connector housing: 8-pin Molex\* 39-01-2080 or equivalent

Contact: Molex\* 39-00-0059 or equivalent



**Table 79. P3 Processor 2 Power Connector**

Pin	Signal	18 AWG Color	Pin	Signal	18 AWG Color
1	COM	Black	5	+12V2	White
2	COM	Black	6	+12V2	White
3	COM	Black	7	+12V2	White
4	COM	Black	8	+12V2	White

**2.4.7.4 Power Signal Connector (P4)**

Connector housing: 5-pin Molex\* 50-57-9405 or equivalent

Contacts: Molex\* 16-02-0087 or equivalent

**Table 80. P4 Power Signal Connector**

Pin	Signal	24 AWG Color
1	I2C Clock	White
2	I2C Data	Yellow
3	Reserved	N.C.
4	COM	Black
5	3.3RS	Orange

**2.4.7.5 PCI Express Connector (P5)**

Connector housing: 6-pin Molex\* 455590002 or equivalent

Contacts: Molex\* Mini-Fit, HCS, Female, Crimp 44476

**Table 81. P5 PCI Express Connector**

PIN	SIGNAL	18 AWG Colors	PIN	SIGNAL	18 AWG Colors
1	+12V4	Green/Yellow strip	4	COM	Black
2	+12V4	Green/Yellow strip	5	COM	Black
3	+12V4	Green/Yellow strip	6	COM	Black

**2.4.7.6 PCI Express Connector (P6)**

Connector housing: 6-pin Molex\* 455590002 or equivalent

Contacts: Molex\* Mini-Fit, HCS, Female, Crimp 44476

**Table 82. P6 PCI Express Connector**

PIN	SIGNAL	18 AWG Colors	PIN	SIGNAL	18 AWG Colors
1	+12V4	Green/Yellow strip	4	COM	Black
2	+12V4	Green/Yellow strip	5	COM	Black
3	+12V4	Green/Yellow strip	6	COM	Black

7.

**2.4.7.7 Peripheral Power Connectors (P9-P12)**

Connector housing: Amp\* 1-480424-0 or equivalent

Contact: Amp\* 61314-1 contact or equivalent

**Table 83. P9-P12 Peripheral Power Connectors**

Pin	Signal	18 AWG Color
1	+12 V5	Green
2	COM	Black
3	COM	Black
4	+5 VDC	Red

**2.4.7.8 Right-Angle SATA Power Connector (P13)**

Connector housing: JWT\* F6002HS0-5P-18 or equivalent

**Table 84. P13 Right-angle SATA Power Connector**

Pin	Signal	18 AWG Color
1	+3.3V	Orange
2	COM	Black
3	+5 VDC	Red
4	COM	Black
5	+12V5	Green

**2.4.7.9 SATA Power Connector (P14)**

Connector housing: JWT\* A3811H00-5P or equivalent;

Contact: JWT\* A3811TOP-0D or equivalent

**Table 85. P14 SATA Power Connector**

Pin	Signal	18 AWG Color
1	+3.3VDC	Orange
2	COM	Black

Pin	Signal	18 AWG Color
3	+5VDC	Red
4	COM	Black
5	+12V5	Green

## 2.4.8 DC Output Specifications

### 2.4.8.1 Output Power / Currents

The following table defines the power and current ratings for the 1000-W power supply. The combined output power of all outputs does not exceed the rated output power. The power supply meets both static and dynamic voltage regulation requirements for the minimum loading conditions.

**Table 86. Load Ratings**

Voltage	Minimum Continuous	Maximum Continuous	Peak Load
+3.3V	1.0 A	24 A	
+5V	2.0 A	30 A	
+12V1	0.5 A	24 A	27 A
+12V2	1.0 A	24 A	27 A
+12V3	0.5 A	16 A	318 A
+12V4	0.5 A	16 A	18 A
+12V5	0.5A	16A	
Voltage	Minimum Continuous	Maximum Continuous	Peak Load
+5VSB	0.1 A	5.0 A	6A

**Notes:**

1. Maximum continuous total DC output power should not exceed 1000 W.
2. Maximum continuous load on the combined 12V output shall not exceed 80 A.
3. Peak load on the combined 12V output shall not exceed 70 A.
4. Peak total DC output power should not exceed 1150 W.
5. Peak power and current loading shall be supported for a minimum of 12 seconds.
6. Combined 3.3V and 5V power shall not exceed 170 W.

### 2.4.8.2 Pre-set Power-on Requirement

When the power supply turns on, system loading may be very light before it comes out of reset. Under these conditions, the power supply's output voltage regulation may be relaxed to +/-10% on the 3.3V and 5V rails and +10 / -8% on the +12V rails. When the power supply is subsequently loaded, it must begin to regulate and source current without fault.

**Table 87. Pre-set Lighter Load**

Voltage	Minimum Continuous Load	Maximum Continuous Load	Peak Load

+3.3V	0 A	9.0 A	
+5V	0 A	7.0 A	
+12V1	0.0 A	8.0 A	
+12V2	0.0 A	8.0 A	
+12V3	0.1 A	8.0 A	
+12V4	0.0 A	8.0 A	
+12V5	0.1A	8.0A	
-12V	0 A	0.5 A	
+5VSB	0.1 A	3.0 A	

**Table 88. Pre-set Lighter Voltage Regulation Limits**

Parameter	Tolerance	MIN	NOM	MAX	Units
+3.3V	- 10% / +10%	+2.970	+3.30	+3.630	V <sub>rms</sub>
+5V	- 10% / +10%	+4.500	+5.00	+5.500	V <sub>rms</sub>
+12V1	- 8% / +10%	+11.04	+12.00	+13.20	V <sub>rms</sub>
+12V2	- 8% / +10%	+11.04	+12.00	+13.20	V <sub>rms</sub>
+12V3	- 8% / +10%	+11.04	+12.00	+13.20	V <sub>rms</sub>
+12V4	- 8% / +10%	+11.04	+12.00	+13.20	V <sub>rms</sub>
+12V5	- 8% / +10%	+11.04	+12.00	+13.20	V <sub>rms</sub>
- 12V	- 5% / +9%	- 11.40	-12.00	-13.08	V <sub>rms</sub>
+5VSB	- 5% / +5%	+4.75	+5.00	+5.25	V <sub>rms</sub>

### 2.4.8.3 Grounding

The output ground of the pins of the power supply provides the power return path. The output connector ground pins are connected to safety ground (power supply enclosure). This grounding is designed to ensure passing the maximum allowed common mode noise levels.

### 2.4.8.4 Standby Output

The 5VSB output is present when an AC input greater than the power supply turn-on voltage is applied.

### 2.4.8.5 Remote Sense

The power supply has remote sense return (ReturnS) to regulate out ground drops for all output voltages: +3.3V, +5V, +12V1, +12V2, +12V3, +12V4, +12V5, -12V, and 5VSB. The power supply uses remote sense to regulate out drops in the system for the +3.3V outputs. The +5V, +12V1, -12V and 5VSB outputs only use remote sense referenced to the ReturnS signal. The remote sense input impedance to the power supply is greater than 200Ω on 3.3V, 5VSB. This is the value of the resistor connecting the remote sense to the output voltage internal to the power supply. Remote sense is able to regulate out a minimum of a 200mV drop on the 3.3 output. The remote sense return (ReturnS) is able to regulate out a minimum of a 200mV drop in the power ground return. The current in any remote sense line is less than 5mA to prevent voltage

sensing errors. The power supply operates within specification over the full range of voltage drops from the power supply's output connector to the remote sense points.

### 2.4.8.6 Voltage Regulation

The power supply output voltages stay within the following voltage limits when operating at steady state and dynamic loading conditions. These limits include the peak-peak ripple/noise.

**Table 89. Voltage Regulation Limits**

Parameter	Tolerance	MIN	NOM	MAX	Units
+ 3.3V	- 5% / +5%	+3.14	+3.30	+3.46	V <sub>rms</sub>
+ 5V	- 5% / +5%	+4.75	+5.00	+5.25	V <sub>rms</sub>
+ 12V1	- 5% / +5%	+11.40	+12.00	+12.60	V <sub>rms</sub>
+ 12V2	- 5% / +5%	+11.40	+12.00	+12.60	V <sub>rms</sub>
+12V3	- 5% / +5%	+11.40	+12.00	+12.60	V <sub>rms</sub>
+12V4	- 5% / +5%	+11.40	+12.00	+12.60	V <sub>rms</sub>
+12V5	- 5% / +5%	+11.40	+12.00	+12.60	V <sub>rms</sub>
- 12V	- 5% / +9%	-10.80	-12.00	-13.20	V <sub>rms</sub>
+ 5VSB	- 5% / +5%	+4.75	+5.00	+5.25	V <sub>rms</sub>

### 2.4.8.7 Dynamic Loading

The output voltages remain within limits specified for the step loading and capacitive loading, as shown in the following table. The load transient repetition rate is tested between 50 Hz and 5 kHz at duty cycles ranging from 10%-90%. The load transient repetition rate is only a test specification. The  $\Delta$  step load may occur anywhere between the MIN load and MAX load conditions.

**Table 90. Transient Load Requirements**

Output	$\Delta$ Step Load Size <sup>12</sup>	Load Slew Rate	Test Capacitive Load
+3.3V	7.0A	0.25 A/ $\mu$ sec	4700 $\mu$ F
+5V	7.0A	0.25 A/ $\mu$ sec	1000 $\mu$ F
+12V	25A	0.25 A/ $\mu$ sec	4700 $\mu$ F
+5VSB	0.5A	0.25 A/ $\mu$ sec	20 $\mu$ F

1. Step loads on each 12V output may happen simultaneously.
2. The +12V should be tested with 2200 $\mu$ F evenly split between the four +12V rails.

### 2.4.8.8 Capacitive Loading

The power supply is stable and meets all requirements with the following capacitive loading ranges.

**Table 91. Capacitive Loading Conditions**

Output	MIN	MAX	Units
+3.3V	250	6800	μF
+5V	400	4700	μF
+12V(1, 2, 3, 4,5)	500 each	11,000	μF
-12V	1	350	μF
+5VSB	20	350	μF

### 2.4.8.9 Closed Loop Stability

The power supply is unconditionally stable under all line / load / transient load conditions, including capacitive load ranges. A minimum of 45 degrees phase margin and -10dB-gain margin are required. Closed-loop stability is ensured at the maximum and minimum loads, as applicable.

### 2.4.8.10 Common Mode Noise

The common mode noise on any output does not exceed 350mV pk-pk over the frequency band of 10Hz to 30MHz.

### 2.4.8.11 Ripple / Noise

The maximum allowed ripple / noise output of the power supply is defined in the following table. This is measured over a bandwidth of 10Hz to 20MHz at the power supply output connectors. A 10μF tantalum capacitor, in parallel with a 0.1μF ceramic capacitor, is placed at the point of measurement.

**Table 92. Ripple and Noise**

+3.3V	+5V	+12V (1,2,3,4,5)	-12V	+5VSB
50mVp-p	50mVp-p	120mVp-p	120mVp-p	50mVp-p

### 2.4.8.12 Soft Starting

The power supply contains a control circuit that provides monotonic soft start for its outputs without overstressing the AC line or any power supply components at any specified AC line or load conditions. There is no requirement for rise time on the 5Vstby but the turn on/off is monotonic.

### 2.4.8.13 Timing Requirements

The timing requirements for power supply operation are as follows. The output voltages must rise from 10% to within regulation limits ( $T_{vout\_rise}$ ) within 5 to 70 ms, except for 5VSB, which is allowed to rise from 1.0 to 25 ms. The +3.3V, +5V and +12V output voltages should start to rise approximately at the same time. All outputs must rise monotonically. Each output voltage shall

reach regulation within 50ms ( $T_{vout\_on}$ ) of each other during turn on of the power supply. Each output voltage shall fall out of regulation within 400msec ( $T_{vout\_off}$ ) of each other during turn off. The following table shows the timing requirements for the power supply being turned on and off via the AC input, with PSON held low and the PSON signal, with the AC input applied.

**Table 93. Output Voltage Timing**

Item	Description	MIN	MAX	Units
$T_{vout\_rise}$	Output voltage rise time from each main output.	5.0 <sup>1</sup>	70 <sup>1</sup>	msec
$T_{vout\_on}$	All main outputs must be within regulation of each other within this time.		50	msec
$T_{vout\_off}$	All main outputs must leave regulation within this time.		400	msec

1. The 5VSB output voltage rise time shall be from 1.0 ms to 25 ms.

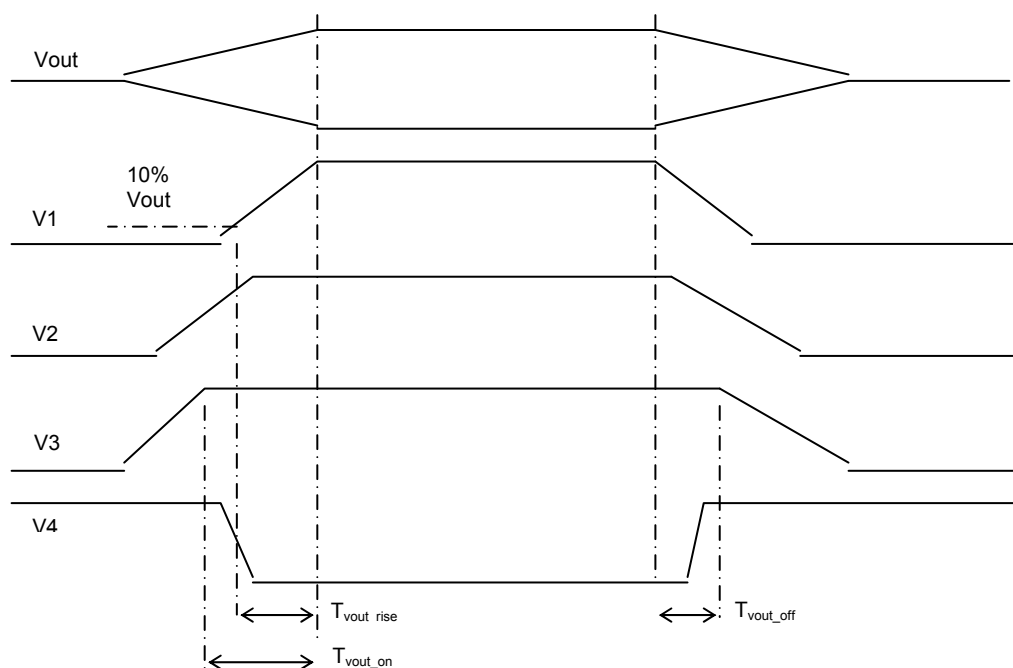

**Figure 19. Output Voltage Timing**

**Table 94. Turn On / Off Timing**

Item	Description	Minimum	Maximum	Units
$T_{sb\_on\_delay}$	Delay from AC being applied to 5VSB being within regulation.		1500	ms
$T_{ac\_on\_delay}$	Delay from AC being applied to all output voltages being within regulation.		2500	ms
$T_{vout\_holdup}$	Time all output voltages stay within regulation after loss of AC.	21		ms

Item	Description	Minimum	Maximum	Units
$T_{pwok\_holdup}$	Delay from loss of AC to de-assertion of PWOK	20		ms
$T_{pson\_on\_delay}$	Delay from PSON# active to output voltages within regulation limits.	5	400	ms
$T_{pson\_pwok}$	Delay from PSON# deactive to PWOK being de-asserted.		50	ms
$T_{pwok\_on}$	Delay from output voltages within regulation limits to PWOK asserted at turn on.	100	500	ms
$T_{pwok\_off}$	Delay from PWOK de-asserted to output voltages (3.3V, 5V, 12V, -12V) dropping out of regulation limits.	1		ms
$T_{pwok\_low}$	Duration of PWOK being in the de-asserted state during an off / on cycle using AC or the PSON signal.	100		ms
$T_{sb\_vout}$	Delay from 5VSB being in regulation to O/Ps being in regulation at AC turn on.	50	1000	ms
$T_{5VSB\_holdup}$	Time the 5VSB output voltage stays within regulation after loss of AC.	70		ms

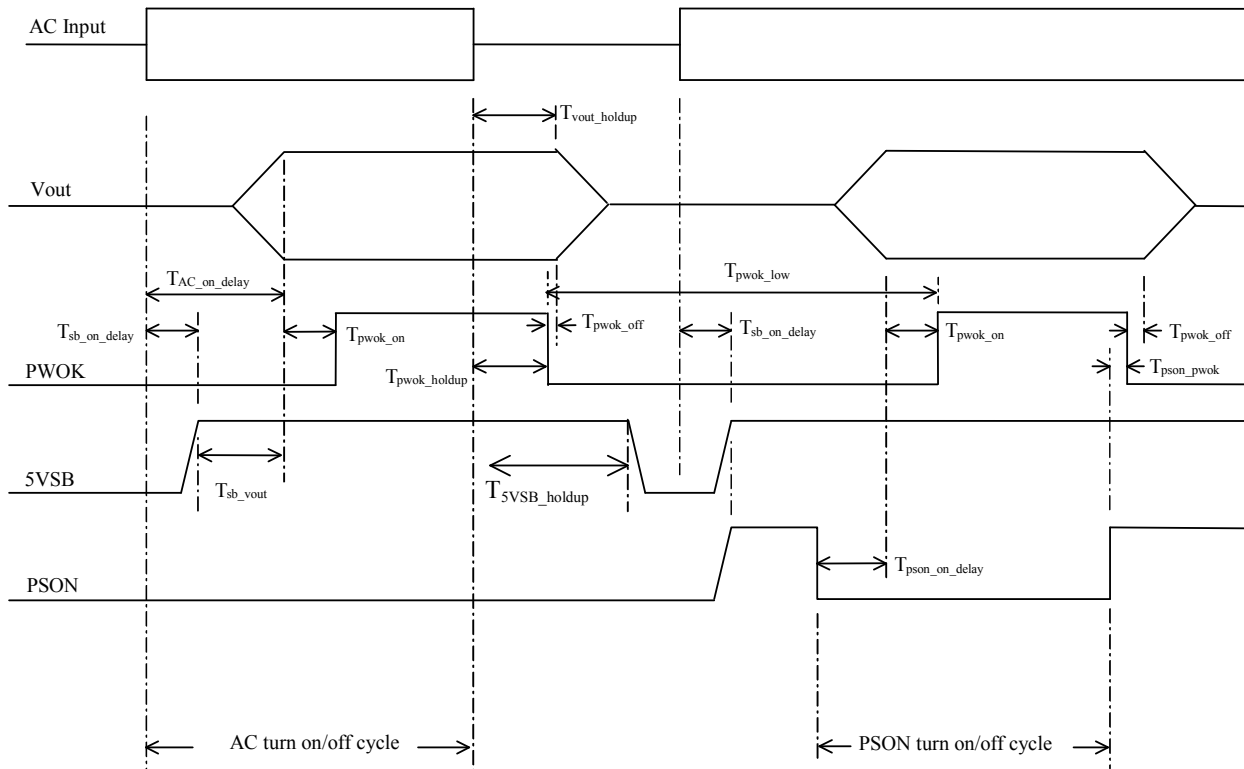

Figure 20. Turn On/Off Timing (Power Supply Signals)

#### 2.4.8.14 Residual Voltage Immunity in Standby mode

The power supply is immune to any residual voltage placed on its outputs (typically a leakage voltage through the system from standby output) up to 500mV. There is no additional heat generated or stress of any internal components with this voltage applied to any individual output, or to all outputs simultaneously. Residual voltage also does not trip the power supply protection circuits during turn on.



Residual voltage at the power supply outputs for a no-load condition does not exceed 100mV when AC voltage is applied and the PSON# signal is de-asserted.

#### 2.4.8.15 Protection Circuits

Protection circuits inside the power supply cause only the power supply's main outputs to shut down. If the power supply latches off due to a protection circuit tripping, an AC cycle OFF for 15 sec and a PSON# cycle HIGH for 1 sec will reset the power supply.

#### 2.4.8.16 Over-current Protection (OCP)

The power supply has a current limit to prevent the +3.3V, +5V, and +12V outputs from exceeding the values shown in the following table. If the current limits are exceeded the power supply will shut down and latch off. The latch will be cleared by toggling the PSON# signal or by an AC power interruption. The power supply will not be damaged from repeated power cycling in this condition. -12V and 5VSB are protected under over-current or shorted conditions so that no damage can occur to the power supply. The 5VSB will auto recover after removing the OCP limit.

**Table 95. Over-current Protection (OCP) 240VA**

Voltage	Over-current Limit		Peak Load	
	MIN	MAX	Peak Limit	Delay
+3.3V	110% = 26.4A	150% = 36A		
+5V	110% = 33A	150% = 45A		
+12V1	18A	20A		
+12V2	18A	20A		
+12V3	18A	20A		
+12V4	18A	20A		
+12V5	18A	20A		
-12V	0.625A	4.0A		
5VSB	7.0A			

#### 2.4.8.17 Over-voltage Protection (OVP)

The power supply over-voltage protection is locally sensed. The power supply will shut down and latch off after an over voltage condition occurs. This latch can be cleared by toggling the PSON# signal or by an AC power interruption. The following table contains the over-voltage limits. The values are measured at the output of the power supply's pins. The voltage never exceeds the maximum levels when measured at the power pins of the power supply connector during any single point of fail. The voltage will not trip any lower than the minimum levels when measured at the power pins of the power supply connector. Exception: The +5VSB rail will auto-recover after an OVP has been cleared.

**Table 96. Over-voltage Protection Limits**

Output Voltage	MIN (V)	MAX (V)
+3.3V	3.9	4.5

Output Voltage	MIN (V)	MAX (V)
+5V	5.7	6.5
+12V1,2, 3, 4,5	13.3	14.5
-12V	-13.3	-16
+5VSB	5.7	6.5

### 2.4.8.18 Over-temperature Protection (OTP)

The power supply is protected against over-temperature conditions caused by loss of fan cooling or excessive ambient temperature. In an OTP condition the power supply will shut down. When the power supply temperature drops to within specified limits, the power supply will restore power automatically; the 5VSB always remains on. The OTP circuit has a built-in hysteresis such that the power supply will not oscillate on and off due to a temperature recovering condition. The OTP trip level has a minimum of 4 degrees C of ambient temperature hysteresis.

### 2.4.9 Control and Indicator Functions

The following sections define the input and output signals from the power supply.

Signals that can be defined as low true use the following convention:

*Signal<sup>#</sup>* = low true

#### 2.4.9.1 PSON# Input Signal

The PSON<sup>#</sup> signal is required to remotely turn on/off the power supply. PSON<sup>#</sup> is an active low signal that turns on the +3.3V, +5V, +12V, and -12V power rails. When this signal is not pulled low by the system, or left open, the outputs (except the +5VSB) turn off. This signal is pulled to a standby voltage by a pull-up resistor internal to the power supply.

**Table 97. PSON# Signal Characteristic**

Signal Type	Accepts an open collector/drain input from the system. Pull-up to VSB located in power supply.	
PSON <sup>#</sup> = Low	ON	
PSON <sup>#</sup> = High or Open	OFF	
	<b>MIN</b>	<b>MAX</b>
Logic level low (power supply ON)	0V	1.0V
Logic level high (power supply OFF)	2.1V	5.25V
Source current, V <sub>pson</sub> = low		4mA
Power up delay: T <sub>pson_on_delay</sub>	5msec	400msec
PWOK delay: T <sub>pson_pwok</sub>		50msec

### 2.4.9.2 PWOK (Power OK) Output Signal

PWOK is a power OK signal and is pulled HIGH by the power supply to indicate that all the outputs are within the regulation limits of the power supply. When any output voltage falls below regulation limits or when AC power has been removed for a time sufficiently long so that power supply operation is no longer guaranteed, PWOK will de-assert to a LOW state. The start of the PWOK delay time is inhibited as long as any power supply output is in current limit.

**Table 98. PWOK Signal Characteristics**

Signal Type	Open collector/drain output from power supply. Pull-up to VSB located in system.	
PWOK = High	Power OK	
PWOK = Low	Power Not OK	
	MIN	MAX
Logic level low voltage, $I_{\text{sink}}=4\text{mA}$	0V	0.4V
Logic level high voltage, $I_{\text{source}}=200\mu\text{A}$	2.4V	5.25V
Sink current, PWOK = low		4mA
Source current, PWOK = high		2mA
PWOK delay: $T_{\text{pwok\_on}}$	100ms	1000ms
PWOK rise and fall time		100 $\mu\text{sec}$
Power down delay: $T_{\text{pwok\_off}}$	1ms	200msec

### 2.4.9.3 LED

There is a single bi-color LED to indicate power supply status. LED operation is defined in the following table.

**Table 99. LED Indicators**

Power Supply Condition	LED
No AC power to all power supplies	Off
Power supply critical event causing a shutdown: failure, OCP, OVP, fan fail	Amber
AC present / Only 5VSB on (power supply off)	1-Hz blink Green
Output ON and OK	Green

The LED is visible on the power supply's exterior face. The LED's location meets ESD requirements. The LED is securely mounted in such a way that incidental pressure on the LED will not cause it to be displaced.

## 2.5 UP 400-Watt Power Supply

The 400-W power supply specification defines a non-redundant power supply that supports UP Intel® Xeon® rack mount server systems. The 400-W power supply has six outputs: 3.3V, 5V, 12V1, 12V2, -12V, and 5VSB. The AC Input is 115V/230V full range and power factor corrected. The form factor is ATX12V.

The power supply incorporates a Power Factor Correction circuit. The power supply is tested as described in EN 61000-3-2: Electromagnetic Compatibility (EMC) Part 3: Limits-Section 2: Limits for Harmonic Current Emissions, and meets the harmonic current emissions limits specified for ITE equipment.

The power supply is tested as described in the JEIDA MITI Guideline for Suppression of High Harmonics in Appliances and General-Use Equipment and meets the harmonic current emissions limits specified for ITE equipment.

### 2.5.1 Mechanical Overview

The physical size of the power supply enclosure is intended to accommodate power ranges from 400 watts. The power supply size is 86X150X140mm and has a wire harness for the DC outputs. The AC plugs directly into the external face of the power supply.

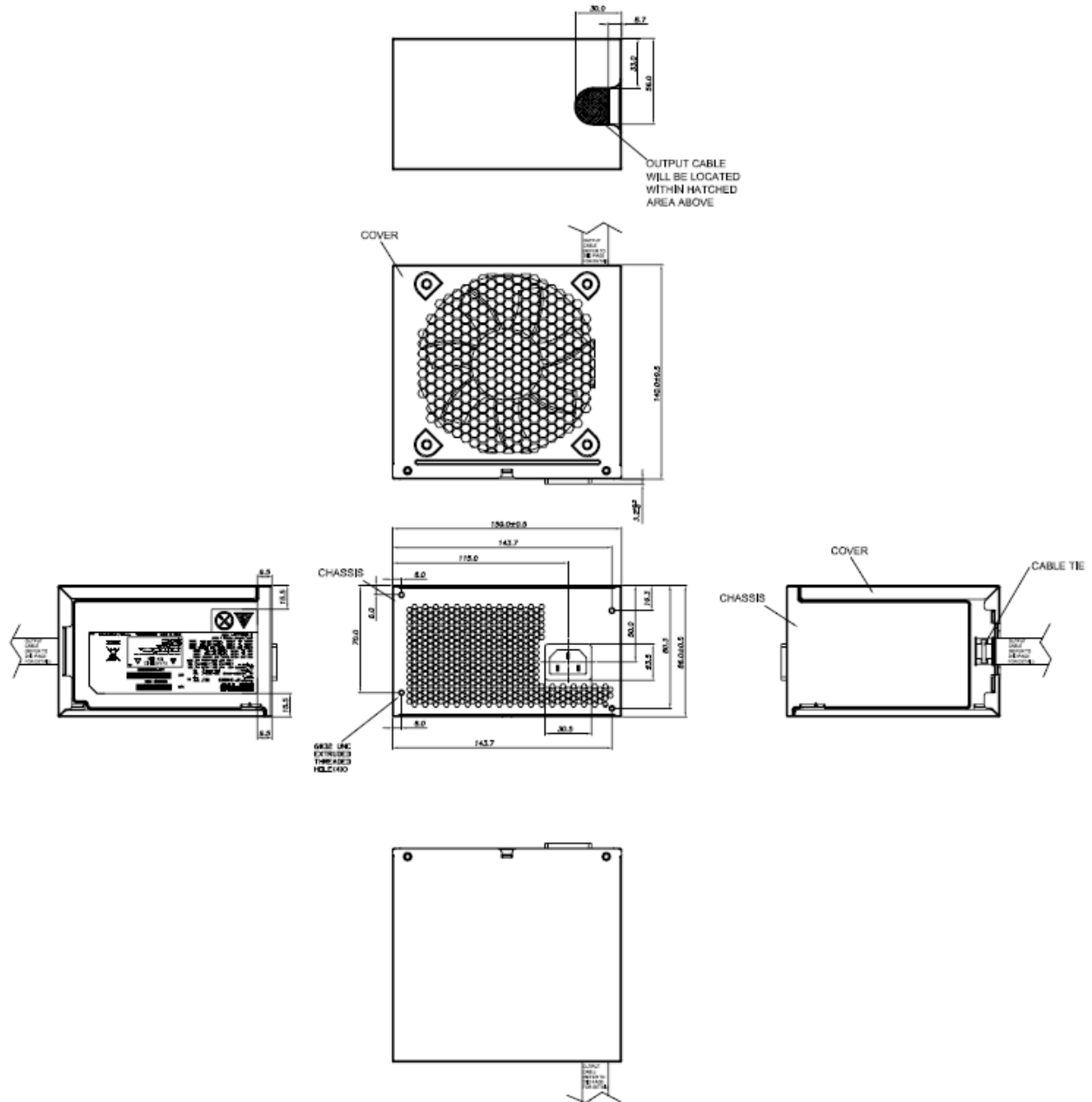

Figure 21. Mechanical Drawing for Power Supply Enclosure

## 2.5.2 Temperature Requirements

The power supply operates within all specified limits over the  $T_{op}$  temperature range.

**Table 100. Thermal Environmental Requirements**

ITEM	DESCRIPTION	MIN	Specification	UNITS
$T_{op}$	Operating temperature range.	0	40	°C
$T_{non-op}$	Non-operating temperature range.	-40	70	°C
Altitude	Maximum operating altitude		10000	Ft

## 2.5.3 Output Cable Harness

Listed or recognized component appliance wiring material (AVLV2), CN, rated min 80°C, 300Vdc is used for all output wiring.

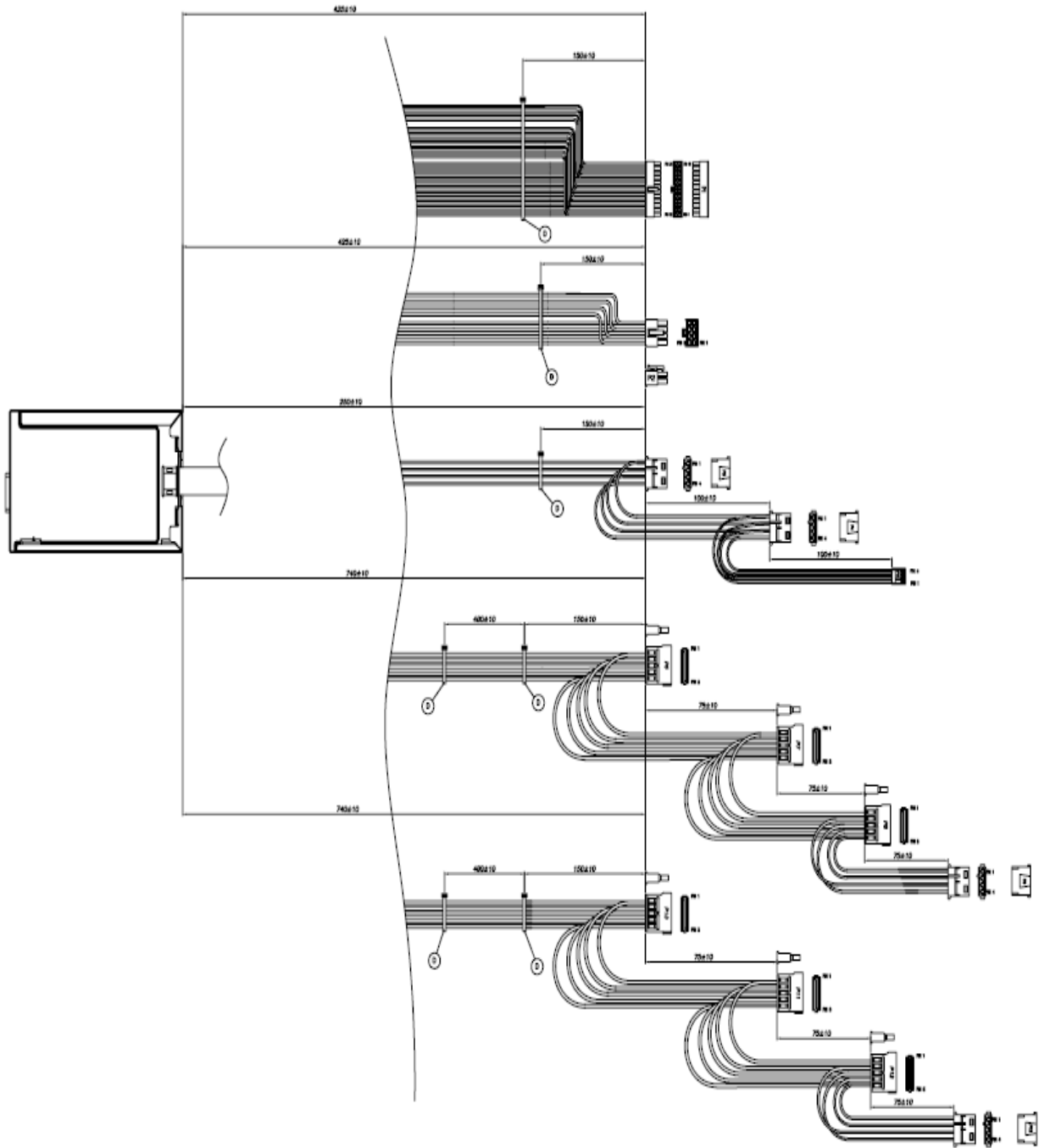

	CONNECTOR PIN	SIGNAL	WIRE COLOR	AWG#	
P1	1	+3.3VDC	ORANGE	18	
	2	+3.3VDC	ORANGE	18	
	3	COM	BLACK	18	
	4	+5VDC	RED	18	
	5	COM	BLACK	18	
	6	+5VDC	RED	18	
	7	COM	BLACK	18	
	8	PWR OK	GRAY	18	
	9	5VSB	PURPLE	18	
	10	+12V2	YELLOW/BLACK	18	
	11	+12V2	YELLOW/BLACK	18	
	12	+3.3VDC	ORANGE	18	
	13		+3.3VDC	ORANGE	18
			REMOTE SENSE	ORANGE	22
	14	-12VDC	BLUE	18	
	15	COM	BLACK	18	
	16	PSON	GREEN	18	
	17	COM	BLACK	18	
	18	COM	BLACK	18	
	19	COM	BLACK	18	
	20	-	-	-	
	21	+5VDC	RED	18	
	22	+5VDC	RED	18	
	23	+5VDC	RED	18	
24	COM	BLACK	18		
P2	1	COM	BLACK	18	
	2	COM	BLACK	18	
	3	COM	BLACK	18	
	4	COM	BLACK	18	
	5	+12V1	YELLOW	18	
	6	+12V1	YELLOW	18	
	7	+12V1	YELLOW	18	
	8	+12V1	YELLOW	18	
P3,P4, P9,P13	1	+12V2	YELLOW/BLACK	18	
	2	COM	BLACK	18	
	3	COM	BLACK	18	
	4	+5VDC	RED	18	
P5	1	+5VDC	RED	18	
	2	COM	BLACK	18	
	3	COM	BLACK	18	
	4	+12V2	YELLOW/BLACK	18	
P6,P7 P8,P10 P11,P12	1	+3.3V	ORANGE	18	
	2	COM	BLACK	18	
	3	+5VDC	RED	18	
	4	COM	BLACK	18	
	5	+12V2	YELLOW/BLACK	18	

Figure 22. Output Cable Harness for 400-W Power Supply

Table 101. Cable Lengths

From	Length	To connector #	No of pins	Description
	(mm)			
Power Supply cover exit hole	425	P1	24	Baseboard Power Connector
Power Supply cover exit hole	425	P2	8	Processor Power Connector
Power Supply cover exit hole	250	P3	4	Peripheral Power Connector



From	Length	To connector #	No of pins	Description
	(mm)			
Extension	100	P4	4	Peripheral Power Connector
Extension from P4	100	P5	4	Floppy Power Connector
Power Supply cover exit hole	740	P6	5	SATA Power Connector
Extension	75	P7	5	SATA Power Connector
Extension from P7	75	P8	5	SATA Power Connector
Extension from P8	75	P9	4	Peripheral Power Connector
Power Supply cover exit hole	740	P10	5	SATA Power Connector
Extension	75	P11	5	SATA Power Connector
Extension from P11	75	P12	5	SATA Power Connector
Extension from P12	75	P13	4	Peripheral Power Connector

### 2.5.3.1 P1 Main Power Connector

Connector housing: 24-pin Molex\* Mini-Fit Jr. 39-01-2245 (94V2) or equivalent  
 Contact: Molex\* Minifit Jr, Crimp 5556 or equivalent

**Table 102. P1 Main Power Connector**

Pin	Signal	18 AWG Color	Pin	Signal	18 AWG Color
1	+3.3 VDC	Orange	13	+3.3 VDC	Orange
2	+3.3 VDC	Orange	14	-12 VDC	Blue
3	COM	Black	15	COM	Black
4	+5 VDC	Red	16	PSO#	Green
5	COM	Black	17	COM	Black
6	+5 VDC	Red	18	COM	Black
7	COM	Black	19	COM	Black
8	PWR OK	Gray	20	Reserved	N.C.
9	5VSB	Purple	21	+5 VDC	Red
10	+12V2	Yellow/Black	22	+5 VDC	Red
11	+12V2	Yellow/Black	23	+5 VDC	Red
12	+3.3 VDC	Orange	24	COM	Black

### 2.5.3.2 P2 Processor/DDR Power Connector

Connector housing: 8-pin Molex\* 39-01-2085(94V2) or equivalent  
 Contact: Molex\*, Mini-Fit Jr, HCS, 44476-1111 or equivalent

**Table 103. P2 Processor #1 Power Connector**

Pin	Signal	18 AWG Color	Pin	Signal	18 AWG Color
1	COM	Black	5	+12V1	Yellow
2	COM	Black	6	+12V1	Yellow
3	COM	Black	7	+12V1	Yellow
4	COM	Black	8	+12V1	Yellow

### 2.5.3.3 Peripheral Power Connector (P3, P4, P9, P13)

Connector housing: Amp\* 1-480424-0 or equivalent

Contact: Amp\* 61314-1 contact or equivalent

**Table 104. Peripheral Power Connector**

Pin	Signal	18 AWG Color
1	+12V2	Yellow/Black
2	COM	Black
3	COM	Black
4	+5 VDC	Red

### 2.5.3.4 Floppy Power Connector (P5)

Connector housing: Amp\* 171822-4 or equivalent

Contacts: Amp\* 170204-1 contact or equivalent

**Table 105. Floppy Power Connector**

Pin	Signal	22 AWG Color
1	+5VDC	Red
2	COM	Black
3	COM	Black
4	<b>+12V2</b>	<b>Yellow/Black</b>

### 2.5.3.5 P6-P8, P10-12 SATA Hard Drive Power Power Connectors

Connector housing: JWT\* A3811H00-5P (94V2) or equivalent

Contact: JWT\* A3811TOP-0D or equivalent

**Table 106. SATA Power Connector**

Pin	Signal	18 AWG Color
1	+3.3V	Orange
2	COM	Black

Pin	Signal	18 AWG Color
3	+5VDC	Red
4	COM	Black
5	+12V2	Yellow/Black

## 2.5.4 AC Input Requirements

The power supply operates within all specified limits over the following input voltage range, shown in the following table. Harmonic distortion of up to 10% of the rated line voltage must not cause the power supply to go out of specified limits. If the AC input is less than 75VAC +/-5VAC range, the power supply does power off. If the AC input is greater than 85VAC, the power supply starts up. Application of an input voltage below 85VAC does not cause damage to the power supply, including a fuse blow.

**Table 107. AC Input Rating**

PARAMETER	MIN	Rated	MAX	Max Input Current	Start up VAC	Power Off VAC
Voltage (110)	90 V <sub>rms</sub>	100-127 V <sub>rms</sub>	140 V <sub>rms</sub>	5.8 A <sub>1,3</sub>	85Vac +/- 4Vac	75Vac +/- 5Vac
Voltage (220)	180 V <sub>rms</sub>	200-240 V <sub>rms</sub>	264 V <sub>rms</sub>	2.9 A <sub>2,3</sub>		
Frequency	47 Hz	50/60Hz	63 Hz			

**Notes:**

1 Maximum input current at low input voltage range shall be measured at 90VAC, at max load.

2 Maximum input current at high input voltage range shall be measured at 180VAC, at max load.

3 This requirement is not to be used for determining agency input current markings.

### 2.5.4.1 AC Inlet Connector

The AC input connector is an IEC 320 C-14 power inlet. This inlet is rated for 10A / 250VAC.

### 2.5.4.2 Efficiency (80+ Bronze)

The following table provides the required minimum efficiency level at various loading conditions. These are provided at three different load levels; 100%, 50% and 20%. Output is loaded according to the proportional loading method defined by 80 Plus. Efficiency is tested per 80 Plus requirement.

**Table 108. Efficiency**

Loading	100% of maximum	50% of maximum	20% of maximum
Minimum Efficiency	82%	85%	82%

### 2.5.4.3 AC Line Dropout / Holdup

Loading	Holdup time
75%	20msec

An AC line dropout is defined to be when the AC input drops to 0VAC at any phase of the AC line for any length of time. During an AC dropout the power supply meets dynamic voltage

regulation requirements. An AC line dropout of any duration does not cause tripping of control signals or protection circuits. If the AC dropout lasts longer than the hold up time the power supply recovers and meets all turn on requirements. The power supply meets the AC dropout requirement over rated AC voltages and frequencies. A dropout of the AC line for any duration does not cause damage to the power supply.

#### 2.5.4.4 AC Line Fuse

The power supply has a one line fuse in the single line fuse on the Line (Hot) wire of the AC input. The line fusing is acceptable for all safety agency requirements. The input fuse is a slow blow type. AC inrush current does not cause the AC line fuse to blow under any conditions. All protection circuits in the power supply do not cause the AC fuse to blow unless a component in the power supply failed. This includes DC output load short conditions.

#### 2.5.4.5 AC In-rush

Peak inrush current does not damage the PSU or the input fuse does not blow under any conditions of load, temperature and input voltage including repeated, rapid cycling of the power line. Half cycle peak inrush current, peak repetitive input current and worst case power factor are provided by the vendor to assist with the UPS and line conditioning, sizing and selection. No component will be stressed over its Max Specification (1.2-t). This must be demonstrated through measurements of the critical component specifications.

#### 2.5.4.6 AC Line Transient Specification

AC line transient conditions are defined as “sag” and “surge” conditions. “Sag” conditions are also commonly referred to as “brownout,” and defined as AC line voltage drops below nominal voltage conditions. “Surge” is defined as AC line voltage rises above nominal voltage conditions.

The power supply meets requirements under the following AC line sag and surge conditions.

**Table 109. AC Line Sag Transient Performance**

Duration	Sag	Operating AC Voltage	Line Frequency	Performance Criteria
0 to 1 AC cycle	95%	Nominal AC Voltage ranges	50/60Hz	No loss of function or performance
> 1 AC cycle	>30%	Nominal AC Voltage ranges	50/60Hz	Loss of function acceptable, self recoverable

**Table 110. AC Line Surge Transient Performance**

Duration	Surge	Operating AC Voltage	Line Frequency	Performance Criteria
Continuous	10%	Nominal AC Voltages	50/60Hz	No loss of function or performance
0 to ½ AC cycle	30%	Mid-point of nominal AC Voltages	50/60Hz	No loss of function or performance

### 2.5.4.7 AC Line Fast Transient (EFT) Specification

The power supply meets the EN 61000-4-5 directive and any additional requirements in IEC1000-4-5:1995 and the Level 3 requirements for surge-withstand capability with the following conditions and exceptions:

- These input transients do not cause any out-of-regulation conditions, such as overshoot and undershoot, nor do they cause any nuisance trips of any of the power supply protection circuits.
- The surge-withstand test does not produce damage to the power supply.
- The power supply meets surge-withstand test conditions under maximum and minimum DC-output load conditions.

### 2.5.4.8 AC Line Leakage Current

The maximum leakage current to ground for each power supply is 3.5 mA when tested at 240 VAC.

## 2.5.5 DC Output Specifications

### 2.5.5.1 Grounding

The ground of the pins of the power supply output connector provides the power return path. The output connector ground pins are connected to the safety ground (power supply enclosure). This grounding is well designed to ensure passing the max allowed Common Mode Noise levels.

The power supply is provided with a reliable protective earth ground. All secondary circuits are connected to protective earth ground. Resistance of the ground returns to chassis does not exceed 1.0 mΩ. This path may be used to carry DC current.

### 2.5.5.2 Standby Output

The 5 VSB output is present when an AC input greater than the power supply turn-on voltage is applied.

### 2.5.5.3 Remote Sense

The power supply uses remote sense to regulate out drops in the system for the +3.3V. The power supply must operate within specification over the full range of voltage drops from the power supply's output connector to the remote sense points.

### 2.5.5.4 Output Power / Currents

The following table defines power and current ratings for this 400W power supply. The combined output power of all outputs does not exceed the rated output power. The power supply meets both static and dynamic voltage regulation requirements for the minimum loading conditions.

**Table 111. Load Ratings**

Parameter	Min	Max.	Peak	Unit
5V	0.3	20.0		A
12V1	1.0	16.0		A
12V2	1.0	16.0		A
3.3V	0.5	20.0		A
- 12V	0.0	0.5		A
5Vstb	0.0	2.5		A

**Notes:**

- 1) Max combined power of 12V1 and 12V2 shall not exceed 350W.
- 2) Max combined power on 3.3V and 5V equal to 130W with current values not exceeding max values of load condition
- 3)+5V/3.5A,+12V/30A and +5V/8A,+12V/5A load combination will be used for cross load regulation

### 2.5.5.5 Voltage Regulation

The power supply output voltages are within the following voltage limits when operating at steady state and dynamic loading conditions. These limits include the peak-peak ripple/noise. All outputs are measured with reference to the return remote sense signal (ReturnS).

**Table 112. Voltage Regulation Limits**

PARAMETER	TOLERANCE	MIN	NOM	MAX	UNITS
+3.3V	- 5% / +5%	+3.14	+3.30	+3.46	Vrms
+5V	- 5% / +5%	+4.75	+5.00	+5.25	Vrms
+12V1	- 5% / +5%	+11.40	+12.00	+12.60	Vrms
+12V2	- 5% / +5%	+11.40	+12.00	+12.60	Vrms
- 12V	- 10% / +10%	- 13.20	-12.00	-10.80	Vrms
+5VSB	- 5% / +5%	+4.75	+5.00	+5.25	Vrms

### 2.5.5.6 Dynamic Loading

The output voltages are within the limits specified for the step loading and capacitive loading requirements specified in the following table. The load transient repetition rate is tested between 50 Hz and 5 kHz at duty cycles ranging from 10%-90%. The load transient repetition rate is only a test specification. The  $\Delta$  step load may occur anywhere within the MIN load and MAX load conditions.

**Table 113. Transient Load Requirements**

Output	$\Delta$ Step Load Size (See note 2)	Load Slew Rate	Test capacitive Load
+3.3V	6.0A	0.25 A/ $\mu$ sec	970 $\mu$ F
+5V	4.0A	0.25 A/ $\mu$ sec	400 $\mu$ F
12V1+12V2	18.0A	0.25 A/ $\mu$ sec	2200 $\mu$ F 1,2
+5VSB	0.5A	0.25 A/ $\mu$ sec	20 $\mu$ F

## Notes

- 1) Step loads on each 12V output may happen simultaneously.
- 2) The +12V should be tested with 2200 $\mu$ F evenly split between the four +12V rails
- 3) +5V/3.5A,+12V/30A and +5V/8A,+12V/5A load combination will be used for cross load regulation.

**2.5.5.7 Capacitive Loading**

The power supply is stable and meets all requirements with the following capacitive loading ranges.

**Table 114. Capacitive Loading Conditions**

Output	MIN	MAX	Units
+3.3V	250	5000	$\mu$ F
+5V	400	5000	$\mu$ F
+12V	500	8000	$\mu$ F
-12V	1	350	$\mu$ F
+5VSB	20	350	$\mu$ F

**2.5.5.8 Closed Loop Stability**

The power supply is unconditionally stable under all line/load/transient load conditions including capacitive load ranges in Section 2.5.5.7. A minimum of a 45-degree phase margin and -10dB-gain margin is required. The power supply manufacturer provides proof of the unit's closed-loop stability with local sensing through the submission of Bode plots. Closed-loop stability is ensured at the maximum and minimum loads as applicable.

**2.5.5.9 Residual Voltage Immunity in Standby Mode**

The power supply is immune to any residual voltage placed on its outputs (typically a leakage voltage through the system from standby output) up to 500mV. There is neither additional heat generated nor stressing of any internal components with this voltage applied to any individual output or all outputs simultaneously. Residual voltage also does not trip the protection circuits during turn on/off.

The residual voltage at the power supply outputs for a no-load condition does not exceed 100 mV when AC voltage is applied.

### 2.5.5.10 Common Mode Noise

The Common Mode noise on any output does not exceed 350mV pk-pk over the frequency band of 10Hz to 20MHz. The measurement is made across a 100Ω resistor between each of the DC outputs including ground at the DC power connector and chassis ground (power subsystem enclosure). The test set-up uses an FET probe, such as a Tektronix\* P6046, or equivalent.

### 2.5.5.11 Soft Starting

The Power Supply contains control circuit which provides monotonic soft start for its outputs without overstress of the AC line or any power supply components at any specified AC line or load conditions.

### 2.5.5.12 Zero Load Stability Requirements

When the power subsystem operates in a no load condition, it does not need to meet the output regulation specification, but it operates without any tripping of over-voltage or other fault circuitry. When the power subsystem is subsequently loaded, it begins to regulate and source current without fault.

### 2.5.5.13 Ripple / Noise

The maximum allowed ripple/noise output of the power supply is defined in the following table. This is measured over a bandwidth of 10 Hz to 20 MHz at the power supply output connectors. A 10μF tantalum capacitor in parallel with a 0.1μF ceramic capacitor is placed at the point of measurement.

**Table 115. Ripple and Noise**

+3.3V	+5V	+12V(1,2)	-12V	+5VSB
50mVp-p	50mVp-p	120mVp-p	120mVp-p	50mVp-p

### 2.5.5.14 Timing Requirements

These are the timing requirements for the power supply operation. The output voltages must rise from 10% to within regulation limits (Tvout\_rise) within 0.2 to 20ms, except for 5VSB - it is allowed to rise from 0.2 to 25ms. The +3.3V, +5V and +12V1,+12V2 output voltages should start to rise approximately at the same time. All outputs must rise monotonically. The 3.3V output will not be greater than the +5V output by 1.5V during any point of the voltage rise condition. The +5V output must never be greater than the +3.3V output by more than 2.25V. Each output voltage shall reach regulation within 50ms (Tvout\_on) of each other during turn on of the power supply. Each output voltage shall fall out of regulation within 400ms (Tvout\_off) of each other during turn off. Table 21 shows the timing requirements for the power supply being turned on and off via the AC input, with PSON held low and the PSON signal, with the AC input applied



**Table 116. Output Voltage Timing**

Item	Description	Minimum	Maximum	Units
$T_{vout\_rise}$	Output voltage rise time from each main output.	0.2*	20*	msec
$T_{vout\_on}$	All main outputs must be within regulation of each other within this time.		50	msec
$T_{vout\_off}$	All main outputs must leave regulation within this time.		400	msec

\* The 5VSB output voltage rise time should be from 0.2 ms to 25 ms.

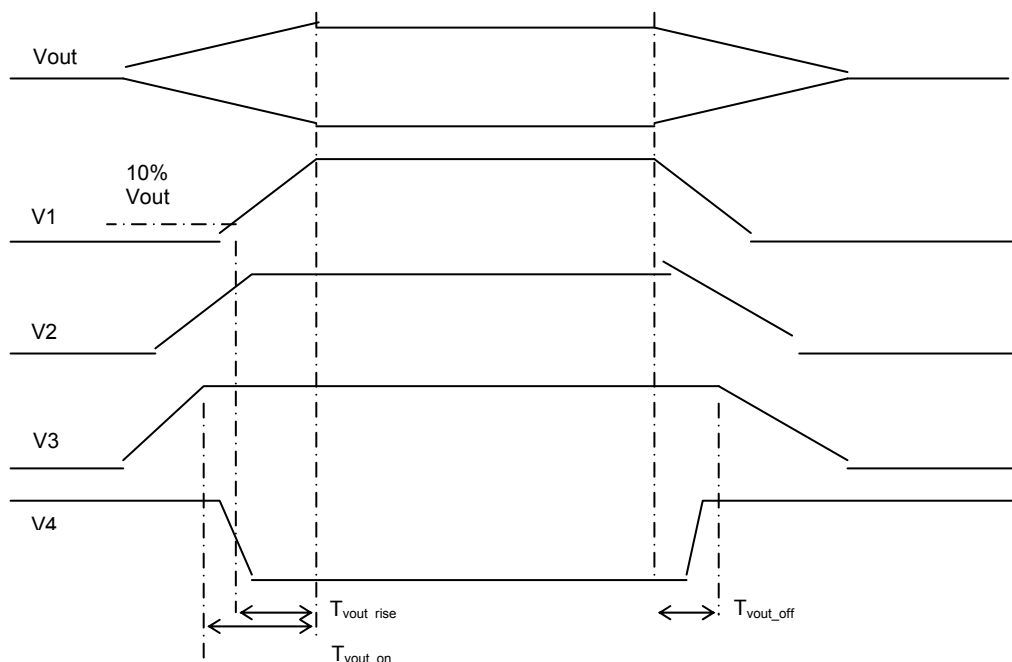
**Figure 23. Output Voltage Timing****Table 117. Turn On / Off Timing**

Item	Description	Minimum	Maximum	Units
$T_{sb\_on\_delay}$	Delay from AC being applied to 5VSB being within regulation.		<b>1500</b>	ms
$T_{ac\_on\_delay}$	Delay from AC being applied to all output voltages being within regulation.		<b>2500</b>	ms
$T_{vout\_holdup}$	Time all output voltages stay within regulation after loss of AC.	<b>10</b>		ms
$T_{pwok\_holdup}$	Delay from loss of AC to de-assertion of PWOK	<b>10</b>		ms
$T_{pson\_on\_delay}$	Delay from PSON# active to output voltages within regulation limits.	<b>5</b>	<b>400</b>	ms
$T_{pson\_pwok}$	Delay from PSON# deactivate to PWOK being de-asserted.		<b>50</b>	ms
$T_{pwok\_on}$	Delay from output voltages within regulation limits to PWOK asserted at turn on.	<b>100</b>	<b>1000</b>	ms
$T_{pwok\_off}$	Delay from PWOK de-asserted to output voltages (3.3V, 5V, 12V, -12V) dropping out of regulation limits.	<b>1</b>		ms
$T_{pwok\_low}$	Duration of PWOK being in the de-asserted state during an off/on cycle using AC or the PSON signal.	<b>100</b>		ms

Item	Description	Minimum	Maximum	Units
$T_{sb\_vout}$	Delay from 5VSB being in regulation to O/Ps being in regulation at AC turn on.	<b>20</b>	<b>1000</b>	ms
$T_{5VSB\_holdup}$	Time the 5VSB output voltage stays within regulation after loss of AC.	<b>10</b>		ms

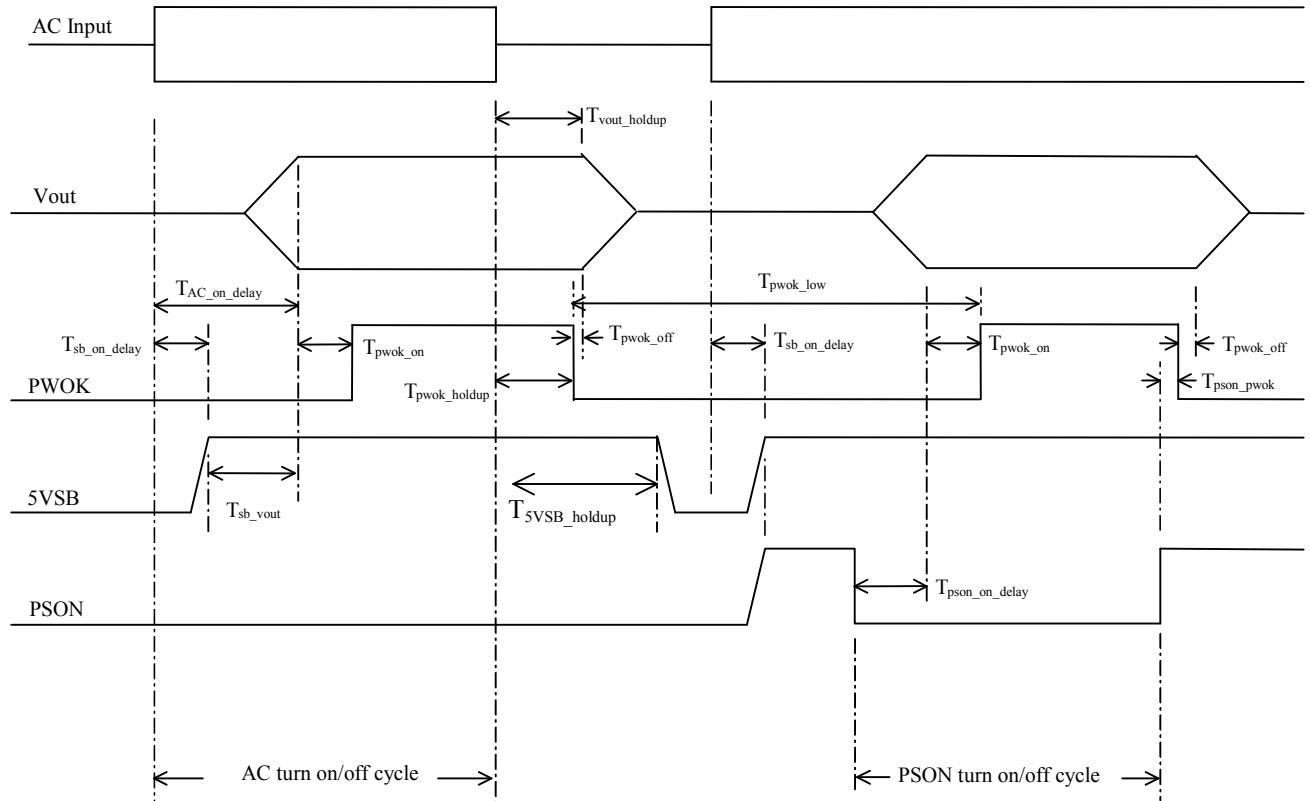

**Figure 24. Turn On/Off Timing (Power Supply Signals)**

## 2.5.6 Protection Circuits

Protection circuits inside the power supply cause only the power supply’s main outputs to shut down. If the power supply latches off due to a protection circuit tripping, an AC cycle OFF for 15 seconds and a PSON# cycle HIGH for 1 second reset the power supply.

### 2.5.6.1 Current Limit (OCP)

Overload currents applied to each tested output rail will cause the output to trip before they reach or exceed 240 VA. For testing purposes, the overload currents of each tested output rail are ramped at a minimum rate of 10 A/sec starting from full load. If the current limits are exceeded the power supply shuts down and latches off. The latch will be cleared by toggling the PSON# signal or by an AC power interruption. The power supply is not damaged from repeated power cycling in this condition. -12V and 5VSB are protected under over current or shorted conditions so that no damage can occur to the power supply. 5Vsb is auto-recovered after removing OCP limit.

### 2.5.6.2 Over Voltage Protection (OVP)

The power supply over voltage protection shall be locally sensed. The power supply shall shutdown and latch off after an over voltage condition occurs. This latch shall be cleared by toggling the PSON# signal or by an AC power interruption. Table 24 contains the over voltage limits. The values are measured at the output of the power supply's pins. The voltage shall never exceed the maximum levels when measured at the power pins of the power supply connector during any single point of fail. The voltage shall never trip any lower than the minimum levels when measured at the power pins of the power supply connector. 5Vsb will be auto-recovered after removing OVP limit.

**Table 118: Over Voltage Protection (OVP) Limits**

Output Voltage	MAX (V)
+3.3V	6.0
+5V	8.0
+12V1,2	18.0
+5VSB	7.0

### 2.5.6.3 Over Temperature Protection (OTP)

The power supply will be protected against over temperature conditions caused by loss of fan cooling or excessive ambient temperature. In an OTP condition the PSU will shutdown.

### 2.5.6.4 Over Temperature Protection (OTP)

The power supply is protected against over temperature conditions caused by loss of fan cooling or excessive ambient temperature. In an OTP condition, the power supply shuts down.

## 2.5.7 Control and Indicator Functions

The following sections define the input and output signals from the power supply. Signals that can be defined as low true use the following convention:  
Signal# = low true

### 2.5.7.1 PSON# Input Signal

The PSON# signal is required to remotely turn on/off the power supply. PSON# is an active low signal that turns on the +3.3V, +5V, +12V1, +12V2 and -12V power rails. When this signal is not pulled low by the system or left open, the outputs (except the +5VSB) turn off. This signal is pulled to a standby voltage by a pull-up resistor internal to the power supply. Refer to the following table and figure for PSON# signal characteristics.

**Table 119. PSON# Signal Characteristics**

Signal Type	Accepts an open collector/drain input from the system. Pull-up to 5 V located in power supply.	
PSON# = Low	ON	
PSON# = High or Open	OFF	
	<b>MIN</b>	<b>MAX</b>
Logic level low (power supply ON)	0V	1.0V
Logic level high (power supply OFF)	2.0V	5.25V
Source current, Vpson = low		4mA
Power up delay: T <sub>pson_on_delay</sub>	5 msec	400 msec
PWOK delay: T <sub>pson_pwok</sub>		50 msec

**Figure 25. PSON# Required Signal Characteristics**

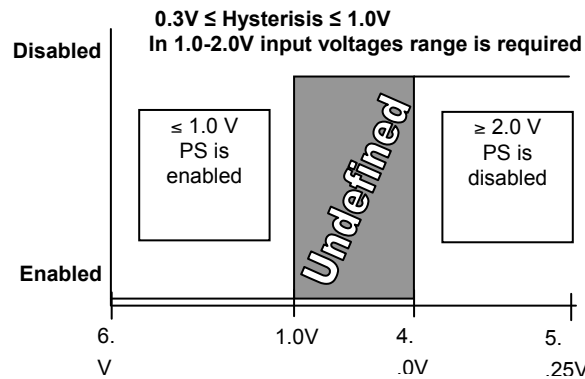

**2.5.7.2 PWOK (Power OK) Output Signal**

PWOK is a power OK signal and is pulled HIGH by the power supply to indicate all the outputs are within the regulation limits of the power supply. When any output voltage falls below regulation limits or when AC power is removed for a time sufficiently long so the power supply operation is no longer guaranteed, PWOK is de-asserted to a LOW state. The start of the PWOK delay time is inhibited as long as any power supply output is within current limit.

**Table 120. PWOK Signal Characteristics**

Signal Type	Open collector/drain output from power supply. Pull-up to VSB located in system.	
PWOK = High	Power OK	
PWOK = Low	Power Not OK	
	<b>MIN</b>	<b>MAX</b>
Logic level low voltage, Isink=4mA	0 V	0.4 V
Logic level high voltage, Isource=200µA	2.4 V	5.25 V
Sink current, PWOK = low		4m A
Source current, PWOK = high		2m A

Signal Type	Open collector/drain output from power supply. Pull-up to VSB located in system.	
PWOK delay: $T_{pwok\_on}$	100 ms	1000 ms
PWOK rise and fall time		100 $\mu$ sec
Power down delay: $T_{pwok\_off}$	1 ms	200 msec

## 3. Chassis Cooling

---

### 3.1 Fan Configuration

The cooling sub-system of the Intel® Server Chassis SC5650 consists of one 120mm chassis fan, one 120mm PCI fan and one 92mm drive bay fan. The cooling sub-system of the Intel® Server Chassis SC5650 UP consists of one 120mm chassis fan and one 92mm drive bay fan. The 4-wire chassis fan provides cooling at the rear of the chassis by drawing fresh air into the chassis from the front and exhausting warm air out the system. This fan is PWM controlled. The server board monitors several temperature sensors and adjusts the duty cycle of the PWM signal to drive the fan at the appropriate speed. The 4-wire PCI fan behind the PCI card guide provides cooling by drawing fresh air from the front of the chassis through PCI fan guide and exhausting it into the PCI bay area. The 4-wire 92-mm drive bay fan provides additional cooling to the drive bay by drawing fresh air from the front of the chassis through drive bay area and exhausting warm air out the bay area.

Removal and insertion of the two 120-mm fans or 92-mm fan can be done without tools. The power supply internal fan assists in drawing air through the peripheral bay area, through the power supply and exhausting it out the rear of the chassis. All versions of the Intel® Server Chassis SC5650 are optimized for server and workstation boards that have an active CPU heatsink solution.

If an optional hot-swap drive bay is installed, a 4-wire 92-mm fan is included with the mounting bracket kit for installation onto the drive bay. This fan has a PWM circuit that allows the server board to control the fan speed based on sensor readings of ambient temperature.

The front panel of the Intel® Server Chassis SC5650 provides a TMP75 temperature sensor for BMC control. Server boards that support BMC control may use the TMP75 sensor to adjust fan speeds according to air intake temperatures. Refer to the server board documentation for configuring use of the front panel sensor.

### 3.2 Server Board Fan Control

The fans provided in the Intel® Server Chassis SC5650 contain a tachometer signal that can be monitored by the server management subsystem for the Intel® Server Boards S5500BC, S5520HC, S5500HCV, S5520SC and S3420GP. See the specific server board Technical Product Specification for details on how this feature works.

### 3.3 Cooling Solution

Air should flow through the system from front to back, as indicated by the arrows in the following figure.

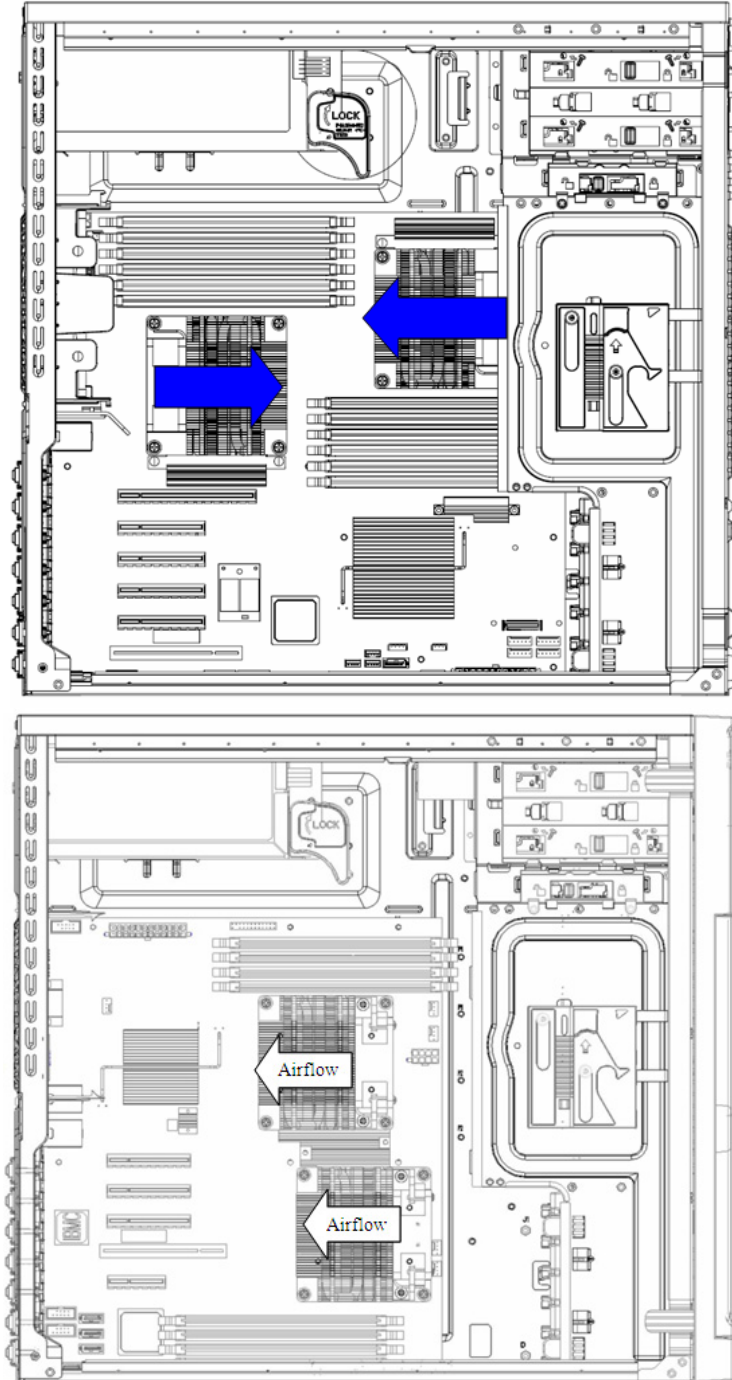

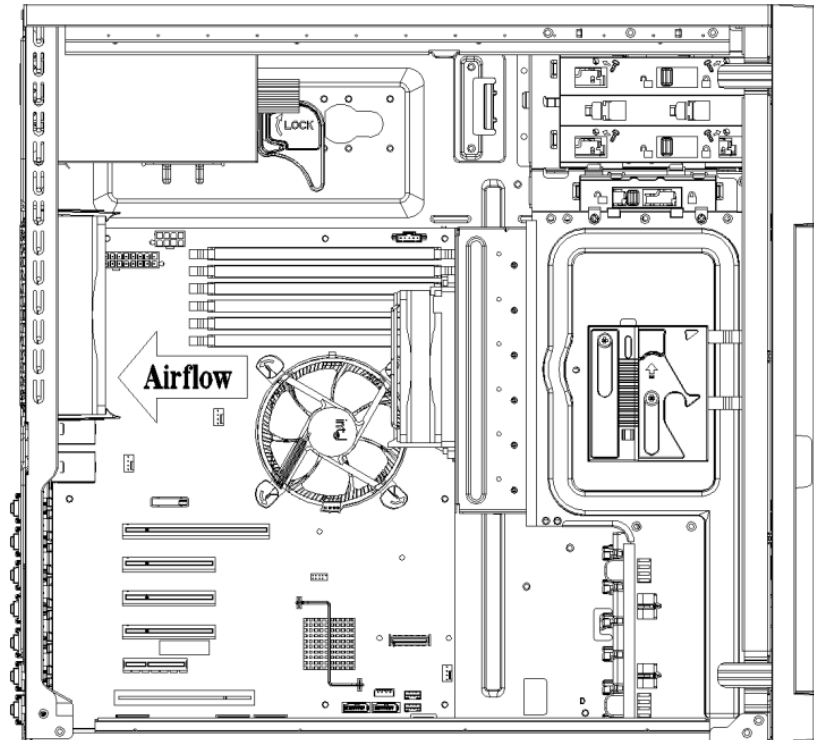

**Figure 26. Cooling Fan Configuration for Intel® Server Boards S5520HC/S5500HCV/S5520SC above, S5500BC middle and S3420GP below**

The Intel® Server Chassis SC5650 is engineered to provide sufficient cooling for all internal components of the server. The cooling subsystem is dependent upon proper airflow. The designated cooling vents on both the front and back of the chassis must be left open and must not be blocked by improperly installed devices. All internal cables must be routed in a manner that does not impede airflow, and ducting provided for CPU cooling must be installed.

Active heatsinks for CPUs incorporate a fan to provide cooling. This thermal solution is included with some boxed Intel® Xeon® processors. The Intel® Server Chassis SC5650 is engineered to work with processors that have an active heatsink solution. Proper installation of the processor cooling solution is required for circulating air toward the rear of the chassis (toward I/O connectors).



## 4. Peripheral and Hard Drive Support

---

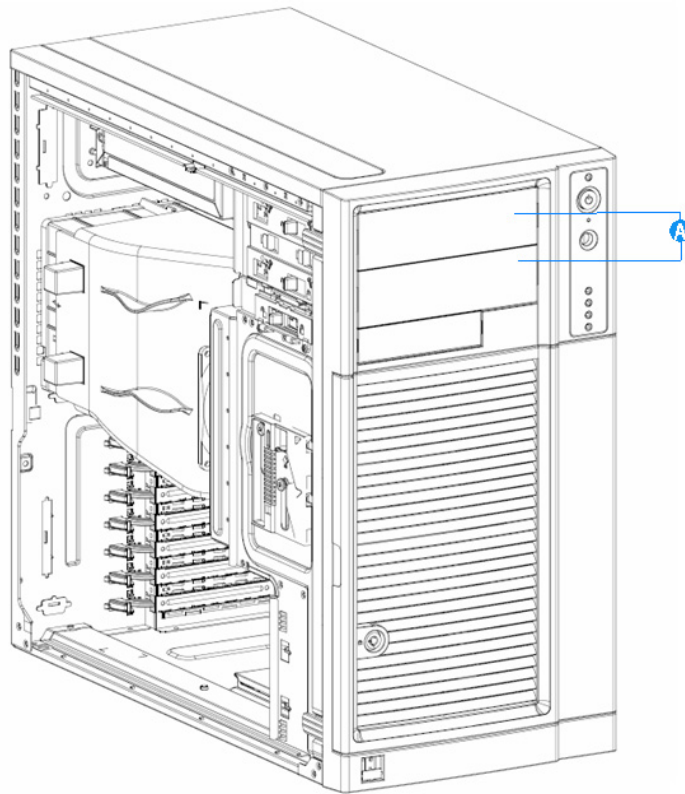

A. Hard Disk Drive Bay

**Figure 27. Drive Bay Locations for Intel® Server Chassis SC5650 (DP/WS/BRP configuration shown)**

### 4.1 3.5-inch Peripheral Drive Bay

The Intel® Server Chassis SC5650 supports one 3.5-inch removable media peripheral, such as a floppy or tape drive, below the 5.25-inch peripheral bays. The bezel must be removed prior to 3.5-inch removable media installation. When a drive is not installed, a snap-in EMI shield must be in place to ensure regulatory compliance. A cosmetic plastic filler is provided to snap into the bezel.

The 3.5-inch bay is designed for tool-less insertion and removal so that no screws are required. On the right side of the chassis, two protrusions in the sheet metal help locate the drive. On the left side are two levers to lock the drive into place.

## 4.2 5.25-inch Peripheral Drive Bays

The Intel® Server Chassis SC5650 supports two half-height 5.25-inch removable media peripheral devices, such as a magnetic/optical disk, CD-ROM drive, or tape drive. These peripherals can be up to 9 inches (228.6 mm) deep on the non-redundant power chassis. The 600-W redundant power supply is longer in length and will limit the drives to approximately 7.5-inch maximum length. As a guideline, the maximum recommended power per device is 17W. Thermal performance of specific devices must be verified to ensure compliance to the manufacturer's specifications.

The 5.25-inch peripherals can be inserted and removed without tools from the front of the chassis after taking off the access cover and removing the front bezel. The peripheral bay utilizes visual guide holes to correctly line up the position of peripheral drives. Locking slide levers push retaining pins into the drive to hold the drive securely in the bay. EMI shield panels are installed and should be retained in unused 5.25-inch bays to ensure proper cooling and EMI conformance.

---

**Note:** Use caution when approaching the maximum level of integration for the 5.25-inch drive bays. Power consumption of the devices integrated needs must be carefully considered to ensure that the maximum power levels of the power supply are not exceeded.

---

## 4.3 Hot Swap Hard Disk Drive Bays

The chassis can support either an active SAS/SATA or a passive SAS/SATA backplane. The backplanes provide platform support for hot-swap SAS or SATA hard drives.

The passive backplane acts as a “pass-through” for the SAS/SATA data from the drives to the SAS/SATA controller on the baseboard or a SAS/SATA controller add-in card. It provides the physical requirements for the hot-swap capabilities. The active backplane has a built-in SAS controller that requires a SAS controller on the baseboard or a SAS add-in card for communication. The active SAS/SATA backplane reduces the number of required cables by using only two SAS/SATA connectors to drive up to six hard drives.

When the hot swap drive bay is installed, a bi-color hard drive LED is located on each drive carrier to indicate specific drive failure or activity. For pedestal systems, these LEDs are visible upon opening the front bezel door.

### 4.3.1 Fixed Hard Drive Bay

The Intel® Server Chassis SC5650 comes with a removable hard drive bay that can accept up to six cabled 3.5-inch x 1-inch hard drives. Power requirements for each individual hard drive may limit the maximum number of drives that can be integrated into an Intel® Server Chassis SC5650. The drive bay is designed to allow adequate airflow between drives, and no additional cooling fan is required. Drives must be installed in the order of slot 1, 3, 5 first (skipping slots) to ensure proper cooling. The drive bay is secured with a tool-less retention mechanism.

---

**Note:** The hard drive bay must be pushed forward or removed to install the server board.

---

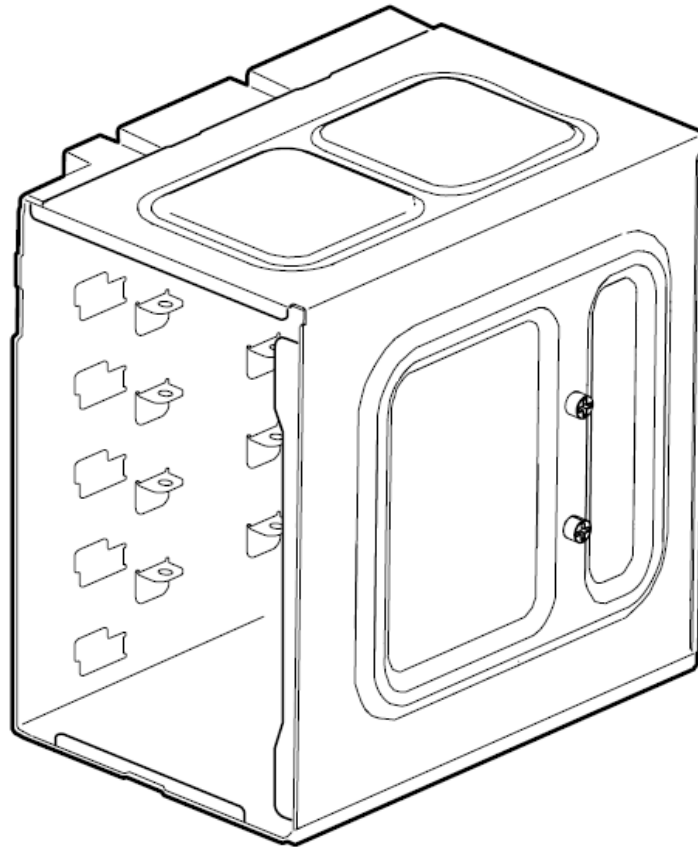

TP00873

The Intel® Server Chassis SC5650 is capable of accepting a single SAS/SATA hot swap backplane hard drive enclosure in place of the fixed drive bay. Both backplanes (expanded and non-expanded) have a connector to accommodate a SAF-TE controller on an add-in card. Each backplane type supports up to six 1-in hot swap drives when mounted in the docking drive carrier.

#### 4.3.2 Intel® Server Chassis SC5650 6HDD Passive SAS/SATA Hot Swap Back Plane (HSBP) Overview

The Intel® Server Chassis SC5650 6HDD Passive SAS/SATA Hot Swap Backplane (HSBP) is a monolithic printed circuit board. The architecture is based on the Vitesse\* Server Board and storage management controller VSC410\* and supports up to four or six SAS/SATA drives.

The 6HDD SAS/SATA HSBP supports the following feature set.

- Vitesse\* Server Board and storage management controller VSC410
- Serial flash memory
- I<sup>2</sup>C EEPROM
- Temperature Sensor
- Four I<sup>2</sup>C interfaces

- One Vitesse\* SFF8485 (SGPIO) Interface
- Compliance with SCSI Accessed Fault Tolerant Enclosures (SAF-TE) specification, version 1.00 and addendum
- Compliance with SCSI Enclosure Service (SES) specification.
- Compliance with Intelligent Platform Management Interface (IPMI) 1.5.
- Support for up to four or six SAS1.5/3.0Gbps, SATA I or SATA II Drives
- Hot swap drive support
- Two 4-pin standard hard drive power connectors

The following figure shows the functional blocks of the passive 6HDD SAS/SATA HSBP.

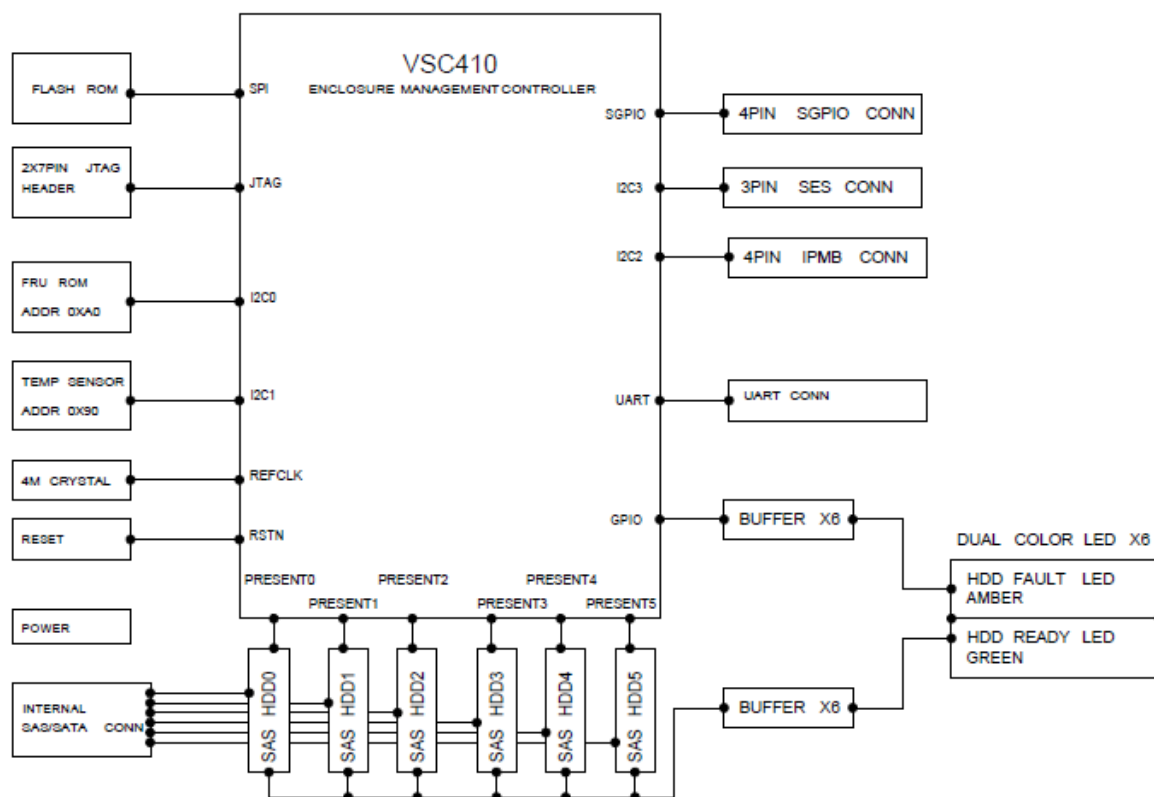

Figure 28. 6HDD Passive SAS/SATA HSBP Block Diagram

### 4.3.3 Server Board and Storage Management Controller VSC410\*

The Vitesse\* VSC410 baseboard and storage management controller for the SAS/SATA backplane monitors various aspects of the storage enclosure. The chip provides out-of-band SAF-TE, SES management through the SAS/SATA Host I<sup>2</sup>C interface and HDD fault LED status management through the SGPIO interface. The VSC410\* also supports the IPMI specification by providing management data to a server board management controller through the IPMB.

The VSC410\* controller has many general purpose input and output pins (GPIOs) that allow customization. Some of these GPIOs are used for hard disk drive detection and driving hard disk drive fault LEDs.

The VSC410\* controller comes in a 64-pin Low Profile Quad Flat Pack (LQFP) package, operates from 3.3V and has an input clock frequency of 4MHz.

#### 4.3.3.1 I<sup>2</sup>C Serial Bus Interface

The VSC410\* controller supports four independent I<sup>2</sup>C interfaces with bus speed of up to 400 Kbits. The I<sup>2</sup>C bus 0 supports an AT24C64\* EEPROM or equivalent I<sup>2</sup>C -based EEPROM used as FRU. The I<sup>2</sup>C bus 1 supports a TI TMP75\* or equivalent I<sup>2</sup>C -based temperature sensor. This enables actual temperature value readings to be returned to the host. The Intelligent Platform Management Bus (IPMB) is supported through the I<sup>2</sup>C port 2. The SCSI Enclosure Service (SES) interface is supported through the I<sup>2</sup>C port 3.

The following figure provides a block diagram of I<sup>2</sup>C bus connection implemented on the 6HDD passive SAS/SATA HSBP.

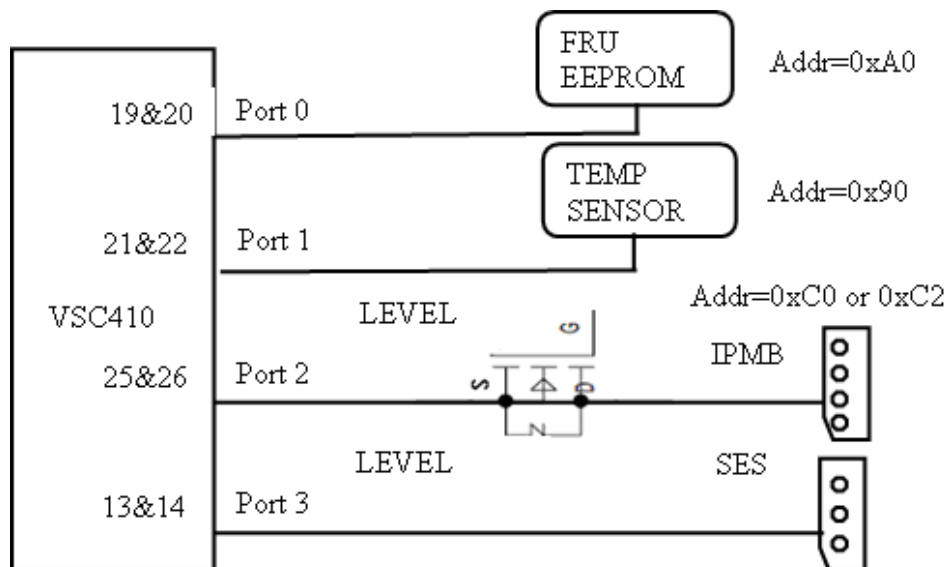

**Figure 29. Passive SAS/SATA HSBP I<sup>2</sup>C Bus Connection Diagram**

### 4.3.3.2 I<sup>2</sup>C Bus Address and Loading

**Table 121. I<sup>2</sup>C Bus Addressing**

TMP75* I <sup>2</sup> C Address	AT24C64* I <sup>2</sup> C Address	VSC410* I <sup>2</sup> C port2
90h	A0h	C0h or C2h

**Table 122. 6HDD I<sup>2</sup>C Bus Loading**

Device	Power Well	V <sub>IH</sub>	V <sub>IL</sub>	V <sub>OL</sub>	I <sub>leak</sub>	CAP	I <sup>2</sup> C Address	I <sup>2</sup> C Bus Name
TMP75*	P3V3	0.7VCC	0.3VCC	0.4V/3mA	1uA	3PF	90h	SMB_LOCAL_CLK SMB_LOCAL_DAT
VSC410*	P3V3	2.0V	0.8V	0.4V/4mA	10uA			SMB_LOCAL_CLK SMB_LOCAL_DAT
AT24C64*	P3V3	0.7VCC	0.3VCC	0.4V/2.1mA	3uA	8PF	A0h	SMB_EEPROM_CLK SMB_EEPROM_DAT
VSC410*	P3V3	2.0V	0.8V	0.4V/4mA	10uA			SMB_EEPROM_CLK SMB_EEPROM_DAT
VSC410*	P3V3	2.0V	0.8V	0.4V/4mA	10uA		C0h or C2h	SMB_3V3_IPMB_CLK SMB_3V3_IPMB_DAT
MMBF170(S)*	P3V3							SMB_3V3_IPMB_CLK SMB_3V3_IPMB_DAT
MMBF170(D)*	P5V							SMB_5VSTB_IPMB_CLK SMB_5VSTB_IPMB_DAT
J4D1	P5V	0.7VCC	0.3VCC	0.4V/3mA	10uA	4/8P		SMB_5VSTB_IPMB_CLK SMB_5VSTB_IPMB_DAT
VSC410*	P3V3	2.0V	0.8V	0.4V/4mA	10uA			SMB_3V3_I2C_CLK SMB_3V3_I2C_DAT
MMBF170(S)*	P3V3							SMB_3V3_I2C_CLK SMB_3V3_I2C_DAT
MMBF170(D)*	P5V							SMB_HBA_I2C_CLK SMB_HBA_I2C_DAT
J4E3	P5V	0.7VCC	0.3VCC	0.4V/3mA	10uA	4/8P		SMB_HBA_I2C_CLK SMB_HBA_I2C_DAT

### 4.3.3.3 Temperature Sensor

The 6HDD passive SAS/SATA HSBP provides a TI TMP75\* or equivalent temperature sensor. The host can query the TMP75\* at any time to read the temperature.

The temperature sensor has an I<sup>2</sup>C address of 0x90h on Port 1 of the VSC410\* controller.

### 4.3.3.4 Serial EEPROM

The 6HDD SAS/SATA HSBP provides an Atmel AT24C64\* or equivalent serial EEPROM for storing the FRU information. The AT24C64\* EEPROM provides 64K bits of serial electrically erasable and programmable read-only memory.

The serial EEPROM has an I<sup>2</sup>C address of 0xA0h and resides on Port 0 of the VSC410\* controller.

#### 4.3.4 General Purpose Input/Output (GPIO)

The VSC410\* controller supports GPIO pins that are customizable. The following table lists the GPIO pins with their assigned functions.

**Table 123. 6HDD VSC410\* Controller GPIO Assignment**

VSC410* Pin Name	I/O Type	Power Well	Programming Description	System Function	Reset State	Initial Value	Connection
P0_0	O	3.3V	U3B1 FLASH ROM and U3C1 EEPROM write protect control	FM_EEPROM_WP			Pull up 4.7K to 3.3V
P0_1	I	3.3V	IPMB Address allocation input	SMB_3V3_IPMB_ADD			Pull up 4.7K to 3.3V
P0_2	O	3.3V	HDD0 Fault LED control	LED_DRV0_FLT_N			Pull up 4.7K to 3.3V
P0_3	I	3.3V	HDD0 Present detection	FM_DRV0_PRSNT_N			Pull up 4.7K to 3.3V
P0_4	O	3.3V	HDD1 Fault LED control	LED_DRV1_FLT_N			Pull up 4.7K to 3.3V
P0_5	I	3.3V	HDD1 Present detection	FM_DRV1_PRSNT_N			Pull up 4.7K to 3.3V
P0_6	O	3.3V	HDD2 Fault LED control	LED_DRV2_FLT_N			Pull up 4.7K to 3.3V
P0_7	I	3.3V	HDD2 Present detection	FM_DRV2_PRSNT_N			Pull up 4.7K to 3.3V
P1_0	O	3.3V	HDD3 Fault LED control	LED_DRV3_FLT_N			Pull up 4.7K to 3.3V
P1_1	I	3.3V	HDD3 Present detection	FM_DRV3_PRSNT_N			Pull up 4.7K to 3.3V
P1_2	O	3.3V	HDD4 Fault LED control	LED_DRV4_FLT_N			Pull up 4.7K to 3.3V
P1_3	I	3.3V	HDD4 Present detection	FM_DRV4_PRSNT_N			Pull up 4.7K to 3.3V
P1_4	O	3.3V	HDD5 Fault LED control	LED_DRV5_FLT_N			Pull up 4.7K to 3.3V
P1_5	I	3.3V	HDD5 Present detection	FM_DRV5_PRSNT_N			Pull up 4.7K to 3.3V
P1_6	O	3.3V	Test Point	TP_LED_DRV6_FLT_N			
P1_7	O	3.3V	Test Point	TP_FM_DRV6_PRSNT_N			
P2_0	O	3.3V	Test Point	TP_LED_DRV7_FLT_N			
P2_1	O	3.3V	Test Point	TP_FM_DRV7_PRSNT_N			
P2_2	O	3.3V	Test Point	TP_LED_DRV8_FLT_N			
P2_3	O	3.3V	Test Point	TP_FM_DRV8_PR SNT_N			

VSC410* Pin Name	I/O Type	Power Well	Programming Description	System Function	Reset State	Initial Value	Connection
P2_4	O	3.3V	Test Point	TP_LED_DRV9_FLT_N			
P2_5	O	3.3V	Test Point	TP_FM_DRV9_PRSENT_N			
P2_6	O	3.3V	Test Point	TP_LED_DRV10_FLT_N			
P2_7	O	3.3V	Test Point	TP_FM_DRV10_PRSENT_N			
P3_0	I/O	3.3V	Clock signal of SGPIO interface	SGPIO_CLK			
P3_1	I/O	3.3V	Load signal of SGPIO interface	SGPIO_LOAD			
P3_2	I/O	3.3V	SDATAIN signal of SGPIO interface	SGPIO_DATAOUT0			
P3_3	I/O	3.3V	SDATAOUT signal of SGPIO interface	SGPIO_DATAOUT1			

### 4.3.5 External Memory Device

The 6HDD passive SAS/SATA HSBP contains a non-volatile 8Mbit Serial SPI FLASH Memory for Boot and Run-Time/Configuration code storage. The device resides on the SPI interface of the VSC410\* controller.

The Serial SPI Flash memory operates from the 3.3V rail.

### 4.3.6 LEDs

The 6HDD passive SAS/SATA HSBPs contain a green STATUS LED and an amber FAULT LED for each of the hard disk drives. The STATUS LED is driven by the SAS/SATA hard disk drive itself. The FAULT LED is driven by the VSC410\* controller whenever a condition, as defined by the firmware, is detected.

**Table 124. LED Function**

Status LED	Condition	Definition
Green	On	HDD Active
	Blink (0.5s on 0.5s off, 50% duty cycle of a 1s)	Spin up/spin down(SAS HDD)
	Blink (1s on 1s off, 50% duty cycle of a 2s)	Formating(SAS HDD)
Amber on	On	HDD Fail
	Blink	Rebuild

**Note:** For SAS drives, the green LED will be on when the drive is installed and ready. For SATA drives, the green LED will be off when the drive is installed and ready.



### 4.3.7 SAS/SATA Drive Connectors

The 6HDD SAS/SATA HSBP provides four or six 22-pin SAS/SATA connectors for hot swap hard disk drives supporting a 1.5GHz and 3.0GHz transfer rate.

**Table 125. 22-pin SAS/SATA Connector Pin-out**

Connector Contact Number	Signal Name
S1	GND
S2	SATA_DRVnA_RX_P
S3	SATA_DRVnA_RX_N
S4	GND
S5	SATA_DRVnA_TX_N
S6	SATA_DRVnA_TX_P
S7	GND
P1	TP_DRVn_P1
P2	TP_DRVn_P2
P3	TP_DRVn_P3
P4	GND
P5	GND
P6	FM_DRVn_PRSENT_N
P7	P5V_DRVn_PRECHG
P8	P5V
P9	P5V
P10	GND
P11	LED_DRVn_READY_N
P12	GND
P13	P12V_DRVn_PRECHG
P14	P12V
P15	P12V

### 4.3.8 Power Connectors

The six HDD passive SAS/SATA HSBP provides two standard 4-pin hard disk drive power connectors. The following table defines the pin-out of the 4-pin power connectors.

**Table 126. Power Connector Pin-out**

Pin	Signal
1	P12V
2	GND
3	GND
4	P5V

### 4.3.9 Clock Generation and Distribution

The 6HDD SAS/SATA HSBP provides one clock source. A 4-MHz crystal provides clock source to the VSC410\* controller.

### 4.3.10 7-Pin SAS/SATA Host Connectors

The 6HDD passive SAS/SATA HSBP provides four or six 7-pin SAS/SATA connectors that will be connected to the host interface of the server board or HBA via a mated cable.

The following table defines the pin-out of the 7-pin SAS/SATA host connector.

**Table 127. 7-pin SAS/SATA Connector Pin-out**

Connector Contact Number	Signal Name
S1	GND
S2	SATA_DRVnA_RX_P
S3	SATA_DRVnA_RX_N
S4	GND
S5	SATA_DRVnA_TX_N
S6	SATA_DRVnA_TX_P
S7	GND

**Note:**

n=0, 1, 2, 3, 4, 5.

### 4.3.11 IPMB Header - IPMB

The following table defines the pin-out of the 4-pin IPMB Header. This connector is white in color.

**Table 128. IPMB Header Pin-out**

Pin	Signal Name	Description
1	SMB_5VSTB_IPMB_DAT	Data
2	GND	GND
3	SMB_5VSTB_IPMB_CLK	Clock
4	SMB_5VSTB_IPMB_ADDR	IPMI interface address selection. Primary (Low)= 0xC0, Secondary(High) = 0xC2

### 4.3.12 SGPIO Header - SGPIO

The following table defines the pin-out of the 4-pin SGPIO Header. This connector is black in color.

**Table 129. SGPIO Header Pin-out**

Pin	Signal Name	Description
1	SGPIO_CLK	Clock
2	SGPIO_LOAD	Load
3	SGPIO_DATAOUT0	DATAIN
4	SGPIO_DATAOUT1	DATAOUT

### 4.3.13 SES Header - SES

The following table defines the pin-out of the 3-pin SES Header. This connector is white in color.

**Table 130. SES Header Pin-out**

Pin	Signal Name	Description
1	SMB_HBA_I2C_DAT	Data
2	GND	Ground
3	SMB_HBA_I2C_CLK	Clock

### 4.3.14 Passive Hot Swap Backplane (HSBP) Cables Explained

Passive backplanes ship with three cables. Depending on the intended configuration, the cables should be utilized in the following manner:

#### 4.3.14.1 IPMB Cable

- Always Installed – white 4-pin IPMB connector on HSBP to white 4 pin IPMB connector on server board
- If using one HSBP (Primary), connect the cable to HSBP\_A on the server board
- If using two HSBPs (Primary and Secondary), connect the second cable to the HSBP\_B on the server board

#### 4.3.14.2 SGPIO Cable

- Always used when using onboard SATA or SAS – black 4-pin connector on HSBP to black 4-pin SGPIO connector on server board
- If using the onboard SATA, connect the cable to the SATA GPIO connector on the server board
- If using the onboard SAS, connect the cable to the SAS GPIO connector on the server board

#### 4.3.14.3 SES Cable

- Only used with SAS controllers – white 3-pin connector on HSBP to white 3-pin SES connector on server board
- Connect to white SES connector on server board, OR
- Connect to SES connector on add-in peripheral card

#### 4.3.14.4 Board Layouts

The figure below shows the board layout and connector placement of the 6HDD passive SAS/SATA HSBP.

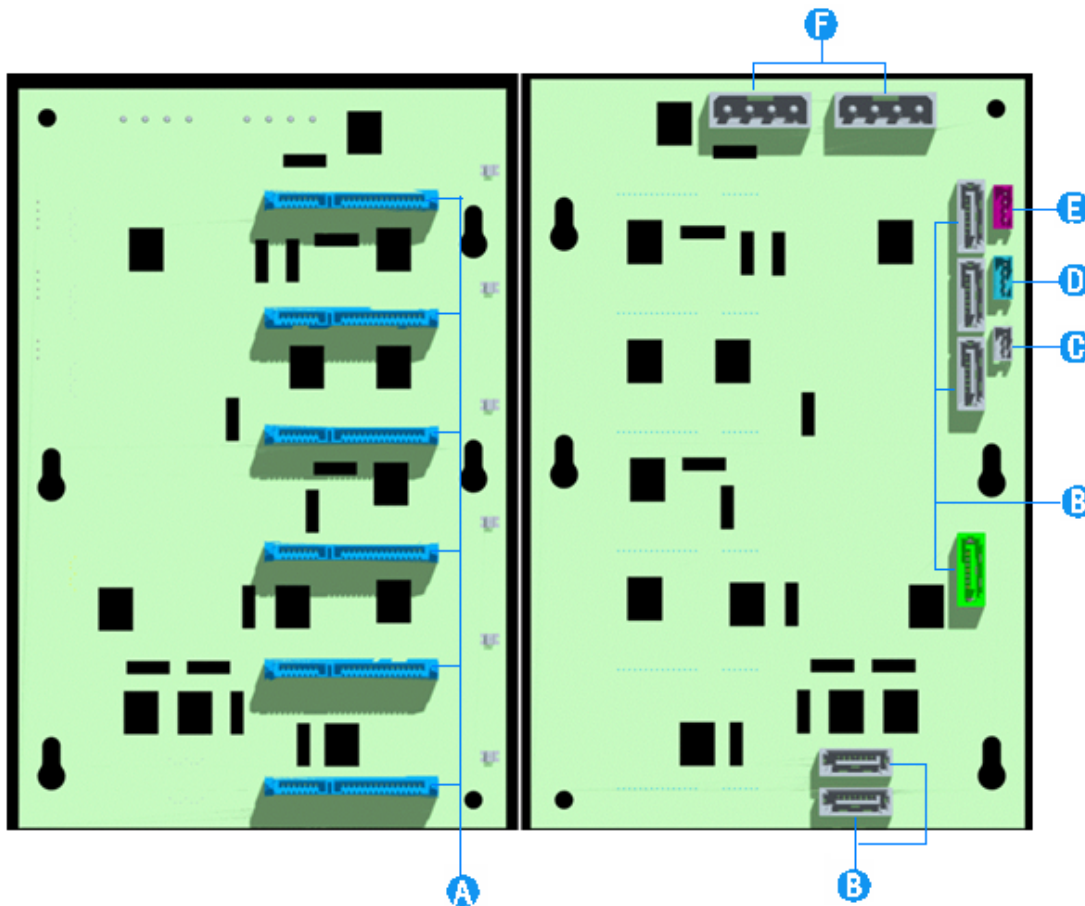

- A. SATA/SAS hot-swap drive connectors
- B. SATA/SAS cable connectors
- C. SES header
- D. SGPIO header
- E. IPMB header
- F. Power connectors

**Figure 30. Intel® Server Chassis SC5650 6HDD Passive SAS/SATA HSBP Board Layout**

### 4.3.15 Connector Specifications

**Table 131. 6HDD Passive SAS/SATA Hot Swap Backplane Connector Specifications**

Quantity	Manufacturer and Part Number	Description	Color	Reference
2	Molex* 15-24-4744	CONN,PWR,4P,STD,PLG,VT,0.2,093ST,DISK D	Black	J3F1,J4F1
6	OTES* ABA-SAT-032-T01	CONN, MISC, 22 P, THM SATA, VT	Black	J3L1,J3M1,J3N1,J3P1,J3R1,J3T1
2	Foxconn* LD1807V-S52TC	CONN,MISC,7 P,THMT SATA,VT, SHRD	Black	J3B1,J3B2, J3C1, J3D1, J3E1, J2E1
1	Wieson* G2420C888-006H	CONN,HDR,1 X 4,PLG,VT,2MM,093ST,KP PG	White	J4D1
1	Wieson* G2420C888-008H	CONN,HDR,1 X 4,PLG,VT,2MM,093ST,KP PG	Black	J4E1
1	Wieson* G2420C888-005H	CONN,HDR,1 X 3,PLG,VT,2MM,093ST,KP PG	White	J4E3

## 5. Standard Control Panel

The Intel® Server Chassis SC5650 control panel configuration has a three-button, five-LED control panel.

When the hot-swap drive bay is installed, a bi-color hard drive LED is located on each drive carrier (six totals) to indicate specific drive failure or activity. These LEDs are visible upon opening the front bezel door.

### 5.1 Control Panel

The control panel buttons and LED indicators are displayed in the following figure. The Entry Ebay SSI (rev 3.61) compliant front panel header for Intel® server boards is located on the back of the front panel. This allows for connection of a 24-pin ribbon cable for use with SSI rev 3.61-compliant server boards. The connector cable is compatible with the 24-pin SSI standard.

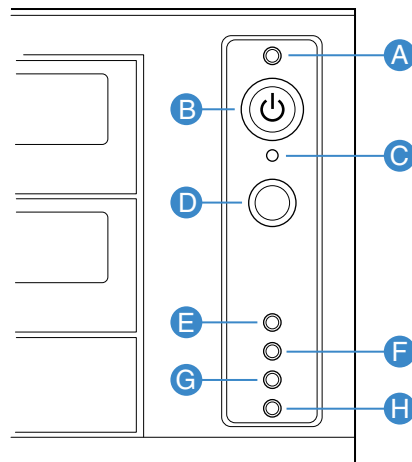

TP00872

- A. Power / Sleep LED
- B. Power button
- C. NMI button
- D. Reset Button
- E. LAN # 1 Activity LED
- F. LAN # 2 Activity LED
- G. Hard Drive Activity LED
- H. Status LED

**Figure 31. Panel Controls and Indicators**

**Table 132. Control Panel LED Functions**

LED Name	Color	Condition	Description
Power/Sleep LED	Green	ON	Power on
		OFF	Power off
LAN # 1- Link/Activity	Green	ON	Linked
		BLINK	LAN activity
		OFF	Disconnected
LAN # 2- Link/Activity	Green	ON	Linked
		BLINK	LAN activity
		OFF	Disconnected
Hard drive activity	Green	BLINK	Hard drive activity
		OFF	No activity
Status LED	Green	ON	System ready (not supported by all server boards)
		BLINK	Processor or memory disabled
	Amber	ON	Critical temperature or voltage fault; CPU/Terminator missing
		BLINK	Power fault; Fan fault; Non-critical temperature or voltage fault
		OFF	Fatal error during POST

---

**Note:** This is dependent on server board support. Not all server boards support all features. For additional details about control panel functions supported for a specific board, refer to the individual server board specifications.

---

## 6. Inter Local Control Panel

The Intel® Local Control Panel (iLCP) utilizes a combination of control buttons, LEDs, and an LCD display to provide system accessibility, monitoring, and control functions independently from the operating system. Combined with an Intel® iBMC Module, the iLCP allows a user to monitor the health of an Intel® server platform or configure an Intel server for remote IPMI management. The control panel assembly is pre-assembled and is modular in design. The module slides into a slot on the front of the chassis and is designed so that it can be adjusted for use with or without an outer front bezel.



Figure 32. SKU3 - Pedestal Server Application

**Note:** The Intel® Local Control Panel can only be used when the Intel® iBMC Module is installed in the system. More information regarding the Intel® Local Control Panel can be found on the Intel support web site.

The following diagram provides an overview of control panel features.



A	LCD Display (Variable content)
B	LCD Up Navigation Button
C	LCD Down Navigation Button
D	LCD Backup Level Navigation Button
E	LCD Command Enter Button

Figure 33. Local Control Panel Components



## 6.1 Internal Control Panel Headers

The control panel interface board has one internal header:

- A 4-pin header provides control and status information to / from the server board via the IPMB interface. A 4-pin round cable connects the iLCP to the server board.

The following table provides the pin-out for each of these headers.

**Table 133. IPMI Header**

Pin #	Description
1	IPMB_5VSB_SDA
2	GND
3	IPMB_5VSB_SCL
4	P5V_STBY

## 7. System Interconnection

---

### 7.1 Signal Definitions

The pin-outs for the connectors referred to in this section are defined in the respective server board Technical Product Specification.

### 7.2 Chassis Internal Cables

#### 7.2.1 Control Panel Cable

A 24-conductor ribbon cable with 24-pin IDC connectors links the control panel to the SSI EEB Revision 3.61-compliant server board.

#### 7.2.2 USB Cable

An 8-conductor USB cable with a 10-pin server board connector and two 4-pin external USB connectors is used to connect the front mounted USB connectors to the server board.

#### 7.2.3 Fan Connector

The installed system fan provides a 4-pin connector that is designed to mate with a SSI (ATX\*)-3 and 4-pin compatible fan header.

#### 7.2.4 Chassis Intrusion Cable

A 2-conductor chassis intrusion cable is included with the chassis kit. It is connected to the control panel through a 2-pin chassis intrusion header on the control panel board.

### 7.3 Server Board Internal Cables

Depending on the specific server board support for these features, some or all of the following cables may be included as part of the boxed board kit:

- Serial cable: One 9-conductor cable terminated in a 2x5 header at one end and a 9-pin panel mount D sub-connector on the other (ships with the server board, not the chassis).
- SATA/SAS data cable: One or more cables with 7 contact connectors. These connectors may feature a right angle or straight housing design.

## 7.4 Accessory Cables

## 7.5 I/O Panel Connectors

The Intel® Server Chassis SC5650 provides an ATX 2.2 and SSI E-bay 3.61-compliant I/O aperture for the backside I/O. The specific panel used will be provided in the boxed server board kit. The following are typical panel connections:

- 9-pin serial port(s)
- USB port(s)
- 15-pin video port
- Ethernet RJ-45 connector(s)

## 7.6 Spares and Accessories

Product Code	Description
APP3RACKIT	Rack conversion kit for Intel Server Chassis SC5650 family. Includes rack rails and hardware for rack installation
FXXPPT600WPSU	Spare 600W PSU for Intel Server Chassis SC5650DP
APPT600WHPSU	2nd Redundant 600W PSU for Intel Server Chassis SC5650BRP. Optional, second module is required to enable full, hot-swap power redundancy
FPPTBRPCAGE	Spare Intel Server Chassis SC5650BRP redundant power supply cage. Also used to upgrade Intel Server Chassis SC5650DP/WS to redundant power configuration. Requires 1 (or 2) APPT600WHPSU to complete upgrade. Includes power distribution board and filler (for empty module when only 1 module installed). See Technical Product Specifications for instructions.
FPPTUPPMKIT	Chassis Preventative Maintenance Kit for Intel Server Chassis SC5650UP. Includes (2) Hard Drive Bay Lockers with Screws and Spring, (1) SC5650UP Air Duct, (1) Intrusion Switch Assembly, (1) USB Cable, (1) Rear 120mm Fan with Fan Holder and Screws, (1) 92mm Fan with Holder and Screws, (1) Full-length PCI Card Guide, (1) Adapter Plate with Screws for Fixed Power Supply, (1) Fixed Power supply tool-less locker, (4) Chassis Feet, , (1) Fixed HDD Fan Plate
FPPTPMKIT	Chassis Preventative Maintenance Kit for Intel Server Chassis SC5650 family. Includes (2) Hard Drive Bay Lockers with Screws and Spring, (1) Air Duct, (1) Intrusion Switch Assembly, (1) USB Cable, (1) Rear 120mm Fixed Fan Holder with Screws, (1) 92mm Fan Holder with Screws, (1) Full-length PCI Card Guide, (4) Rivets for front 120mm Fixed Fan, (1) Adapter Plate with Screws for Fixed Power Supply, (1) Fixed Power

Product Code	Description
	supply tool-less locker, (4) Chassis Feet, , (1) Fixed HDD Fan Plate, (1) Supporting kit for upgrading to redundant power supply on SC5650DP/WS
FPPTFANKIT4W	4 wire fan kit for Intel Server Chassis SC5650. Includes (1) 4 wire PCI Fan(120mm) & (2) 4 wire rear fan(120mm) & (1) 4 wire HDD fan(90mm).
APPTHSDBKIT	Hot-swap drive cooling and mounting Kit for Intel Server Chassis SC5650, Includes 1 fan holder and 2 Hot-swap cage brackets. This mounting kit is required when using 6-bay Hot-swap Hard Disk Cage AXX6DRV3GR in SC5650 Chassis
APP3HSDBKIT	Hot-swap adapter bracket for use with all Intel Server Chassis SC5299-E, SC5295 (except SC5295UP) and SC5650 chassis. This mounting kit is required when using 6-bay Hot-swap Hard Disk Cage AXX6DRV3GEXP in SC5650 Chassis
APP3STDBEZEL	Spare bezel with door for Intel Server Chassis SC5650 family.
FXXPPTFPBRD	Spare front panel board for Intel Server Chassis SC5650
AXX6DRV3GEXP	6-drive hot-swap, expander SATA/SAS backplane assembly cage kit for Intel Server Chassis SC5600/SC5650. Requires 2 SAS ports from SAS personality module or RAID card and is compatible with SAS or SATA 3.5" hard drives. Includes: backplane board, 6 drive carriers, 2 Data cables, 6-drive bay, IPMB cable, common installation guide, SATA/SAS configuration label
AXX6DRV3GR	6-drive hot-swap non-expanded SATA/SAS backplane assembly cage kit for Intel Server Chassis SC5600 / SC5650 family. Requires 6 SAS ports from RAID card for SAS (or SATA) 3.5" hard drive support or 6 SATA ports from baseboard or RAID card for SATA 3.5" hard drive support. Includes: Backplane board, 6 drive carriers, 6 data cables, 6-drive bay, IPMB cable, SES cable and SGPIO cable, common installation guide, SATA/SAS configuration label.

## 8. Supported Intel® Server Boards

---

The Intel® Server Chassis SC5650 is mechanically and functionally designed to support the following Intel® server boards:

- Intel® Server Board S5520HC
- Intel® Server Board S5500HCV
- Intel® Server Board S5520SC
- Intel® Server Board S5500BC
- Intel® Server Board S3420GP

## 9. Regulatory, Environmental, and Specifications

---

### 9.1 Product Regulatory Compliance

#### **WARNING**

To ensure regulatory compliance, you must adhere to the assembly instructions included with this chassis to ensure and maintain compliance with existing product certifications and approvals. Use only the described, regulated components specified in this specification. Use of other products / components will void the UL listing and other regulatory approvals of the product and will most likely result in noncompliance with product regulations in the region(s) in which the product is sold.

The final configuration of your end system product may require additional EMC compliance testing. For more information, please contact your local Intel Representative.

This is an FCC Class A device. Integration of it into a Class B chassis does not result in a Class B device.

This server chassis product, when correctly integrated, complies with the following safety and electromagnetic compatibility (EMC) regulations.

#### 9.1.1 Product Safety Compliance

The Intel® Server Chassis SC5650 complies with the following safety requirements:

- UL60950 – CSA 60950(USA / Canada)
- EN60950 (Europe)
- IEC60950 (International)
- CB Certificate & Report, IEC60950 (report to include all country national deviations)
- GS License (Germany)
- GOST R 50377-92 - License (Russia)
- Belarus Licence (Belarus)
- Ukraine Licence (Ukraine)
- CE - Low Voltage Directive 73/23/EEE (Europe)
- IRAM Certification (Argentina)

#### 9.1.2 Product EMC Compliance – Class A Compliance

The Intel® Server Chassis SC5650 has been tested and verified to comply with the following electromagnetic compatibility (EMC) regulations when configured with an Intel® compatible server board. For information on compatible server boards, refer to the Intel website or contact your local Intel representative.

- FCC /ICES-003 - Emissions (USA/Canada) Verification
- CISPR 22 – Emissions (International)

- EN55022 - Emissions (Europe)
- EN55024 - Immunity (Europe)
- EN61000-3-2 - Harmonics (Europe)
- EN61000-3-3 - Voltage Flicker (Europe)
- CE – EMC Directive 89/336/EEC (Europe)
- VCCI Emissions (Japan)
- AS/NZS 3548 Emissions (Australia / New Zealand)
- BSMI CNS13438 Emissions (Taiwan)
- GOST R 29216-91 Emissions (Russia)
- GOST R 50628-95 Immunity (Russia)
- Belarus License (Belarus)
- Ukraine License (Ukraine)
- RRL MIC Notice No. 1997-41 (EMC) & 1997-42 (EMI) (Korea)

### 9.1.3 Product Ecology Requirements

- All materials, parts and subassemblies do not contain restricted materials as defined in Intel's Environmental Product Content Specification of Suppliers and Outsourced Manufacturers. The Environmental Content Specification includes the ban of substances noted in the European Restriction of Hazardous Substances (RoHS) Directive 2002/95/EC – <http://supplier.intel.com/ehs/environmental.htm>.
- Plastic parts do not use brominated flame retardant or any other halogenated retardants that are not accepted by environmental programs, such as Blue Angels, Nordic White Swan, and Swedish TCO.
- All plastic parts that weigh >25gm are marked with the ISO11469 requirements for recycling. Example: >PC/ABS<
- Packaging materials may not contain more than 100 ppm (total) of lead, cadmium, chromium or mercury.
- If sold as a retail product, packaging materials must be marked with applicable recycling logos for Europe (green dot) and Japan (Eco-marks).
- All cords and cables contain <100 ppm of cadmium.







### 9.1.4 Certifications / Registrations / Declarations

- UL Certification (US/Canada)
- CE Declaration of Conformity (CENELEC Europe)
- FCC/ICES-003 Class A Attestation (USA/Canada)
- VCCI Certification (Japan)
- C-Tick Declaration of Conformity (Australia)
- MED Declaration of Conformity (New Zealand)
- BSMI Certification (Taiwan)
- GOST R Certification / Licence (Russia)
- Belarus Certification / Licence (Belarus)
- RRL Certification (Korea)
- IRAM Certification (Argentina)

- Ecology Declaration (International)

### 9.1.5 Product Regulatory Compliance Markings

This Intel® server chassis products have the following regulatory marks.

Regulatory Compliance	Region	Marking
cULus Listing Marks	USA/Canada	
GS Mark	Germany	
CE Mark	Europe	
FCC Marking (Class A)	USA	This device complies with Part 15 of the FCC Rules. Operation of this device is subject to the following two conditions: (1) This device may not cause harmful interference, and (2) This device must accept any interference received, including interference that may cause undesired operation. Manufactured by Intel Corporation
EMC Marking (Class A)	Canada	CANADA ICES-003 CLASS A CANADA NMB-003 CLASSE A
C-Tick Mark	Australia / New Zealand	
VCCI Marking (Class A)	Japan	この装置は、クラス A 情報技術装置です。この装置を家庭環境で使用すると電波妨害を引き起こすことがあります。この場合には使用者が適切な対策を講ずるよう要求されることがあります。VCCI-A
BSMI Certification Number & Class A Warning	Taiwan	 <div style="border: 1px solid black; padding: 5px; width: fit-content;"><b>警告使用者：</b> 這是甲類的資訊產品，在居住的環境中使用時，可能會造成射頻干擾，在這種情況下，使用者會被要求採取某些適當的對策</div>
Regulatory Compliance	Region	Marking
GOST R Marking	Russia	
RRL MIC Mark	Korea	



## 9.2 Electromagnetic Compatibility Notices

### 9.2.1 FCC Verification Statement (USA)

This device complies with Part 15 of the FCC Rules. Operation is subject to the following two conditions:

1. This device may not cause harmful interference.
2. This device must accept any interference received, including interference that may cause undesired operation.

Intel Corporation  
5200 N.E. Elam Young Parkway  
Hillsboro, OR 97124-6497  
Phone: 1-800-628-8686

This equipment has been tested and found to comply with the limits for a Class A digital device, pursuant to Part 15 of the FCC Rules. These limits are designed to provide reasonable protection against harmful interference in a residential installation. This equipment generates, uses, and can radiate radio frequency energy and, if not installed and used in accordance with the instructions, may cause harmful interference to radio communications. However, there is no guarantee that interference will not occur in a particular installation. If this equipment does cause harmful interference to radio or television reception, which can be determined by turning the equipment off and on, the user is encouraged to try to correct the interference by one or more of the following measures:

- Re-orient or relocate the receiving antenna.
- Increase the separation between the equipment and the receiver.
- Connect the equipment to an outlet on a circuit different from that to which the receiver is connected.
- Consult the dealer or an experienced radio / TV technician for help.

Any changes or modifications not expressly approved by the grantee of this device could void the user's authority to operate the equipment. The customer is responsible for ensuring compliance of the modified product.

Only peripherals (computer input / output devices, terminals, printers, etc.) that comply with FCC Class A or B limits may be attached to this computer product. Operation with non-compliant peripherals is likely to result in interference to radio and TV reception.

All cables used to connect to peripherals must be shielded and grounded. Operation with cables connected to peripherals that are not shielded and grounded may result in interference to radio and TV reception.

## 9.2.2 ICES-003 (Canada)

Cet appareil numérique respecte les limites bruits radioélectriques applicables aux appareils numériques de Classe A prescrites dans la norme sur le matériel brouilleur: "Appareils Numériques", NMB-003 édictée par le Ministre Canadian des Communications.

(English translation of the notice above) This digital apparatus does not exceed the Class A limits for radio noise emissions from digital apparatus set out in the interference-causing equipment standard entitled "Digital Apparatus," ICES-003 of the Canadian Department of Communications.

## 9.2.3 Europe (CE Declaration of Conformity)

This product has been tested in accordance to, and complies with the Low Voltage Directive (73/23/EEC) and EMC Directive (89/336/EEC). The product has been marked with the CE Mark to illustrate its compliance.

## 9.2.4 Japan EMC Compatibility

Electromagnetic Compatibility Notices (International)

この装置は、情報処理装置等電波障害自主規制協議会（VCCI）の基準に基づくクラスA情報技術装置です。この装置を家庭環境で使用すると電波妨害を引き起こすことがあります。この場合には使用者が適切な対策を講ずるよう要求されることがあります。

English translation of the above notice:

This is a Class A product based on the standard of the Voluntary Control Council For Interference (VCCI) from Information Technology Equipment. If this is used near a radio or television receiver in a domestic environment, it may cause radio interference. Install and use the equipment according to the instruction manual.

## 9.2.5 BSMI (Taiwan)

The BSMI Certification number and the following warning is located on the product safety label, which is located on the bottom side (pedestal orientation) or side (rack mount configuration).

警告使用者：

這是甲類的資訊產品，在居住的環境中使用時，可能會造成射頻干擾，在這種情況下，使用者會被要求採取某些適當的對策。

## 9.2.6 RRL (Korea)

Following is the RRL certification information for Korea.

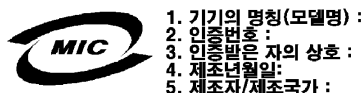

### English translation of the notice above:

1. Type of Equipment (Model Name): On License and Product
2. Certification No.: On RRL certificate. Obtain certificate from local Intel representative
3. Name of Certification Recipient: Intel Corporation
4. Date of Manufacturer: Refer to date code on product
5. Manufacturer/Nation: Intel Corporation/Refer to country of origin marked on product

## 9.3 Regulated Specified Components

To maintain the UL listing and compliance to other regulatory certifications and/or declarations, the following regulated components must be used and conditions adhered to. Interchanging or use of other component will void the UL listing and other product certifications and approvals.

- **Server Chassis** - (Base chassis is provided with power supply and fans)—UL listed.
- **Server board** - Must use an Intel® server board—UL recognized.
- **Add-in boards** - Must have a printed wiring board flammability rating of minimum UL94V-1. Add-in boards containing external power connectors and / or lithium batteries must be UL recognized or UL listed. Any add-in board containing modem telecommunication circuitry must be UL listed. In addition, the modem must have the appropriate telecommunications, safety, and EMC approvals for the region in which it is sold.
- **Peripheral Storage Devices** - must be UL recognized or UL listed accessory and TUV or VDE licensed. Maximum power rating of any one device is 19 watts. Total server configuration is not to exceed the maximum loading conditions of the power supply.

## 9.4 End of Life / Product Recycling

Product recycling and end-of-life take back systems and requirements vary from country to country. Contact the retailer or distributor of this product for information on product recycling and / or take back.

## 9.5 Restriction of Hazardous Substances (RoHS) Compliance

Intel has a system in place to restrict the use of banned substances in accordance with the European Directive 2002/95/EC. Compliance is based on declaration that materials banned in the RoHS Directive are either (1) below all applicable substance threshold limits, or (2) an approved/pending RoHS exception applies.

---

**Note:** RoHS implementing details are not fully defined and may change.

---

Threshold limits and banned substances are noted as follows:

- Quantity limit of 0.1% by mass (1000 PPM) for:
  - Lead
  - Mercury
  - Hexavalent Chromium
  - Polybrominated Biphenyls Diphenyl Ethers (PBDE, PBB)
- Quantity limit of 0.01% by mass (100 PPM) for:
  - Cadmium

## 9.6 Replacing the Back up Battery

The lithium battery on the server board powers the real time clock (RTC) for up to 10 years in the absence of power. When the battery starts to weaken, it loses voltage, and the server settings stored in CMOS RAM in the RTC (for example, the date and time) may be wrong. Contact your customer service representative or dealer for a list of approved devices.



### WARNING

Danger of explosion if battery is incorrectly replaced. Replace only with the same or equivalent type recommended by the equipment manufacturer. Discard used batteries according to manufacturer's instructions.



### ADVARSEL!

Lithiumbatteri - Eksplosionsfare ved fejlagtig håndtering. Udskiftning må kun ske med batteri af samme fabrikat og type. Levér det brugte batteri tilbage til leverandøren.



### ADVARSEL

Lithiumbatteri - Eksplosjonsfare. Ved utskifting benyttes kun batteri som anbefalt av apparatfabrikanten. Brukt batteri returneres apparatleverandøren.



### WARNING

Explosionsfara vid felaktigt batteribyte. Använd samma batterityp eller en ekvivalent typ som rekommenderas av apparattillverkaren. Kassera använt batteri enligt fabrikantens instruktion.



### VAROITUS

Paristo voi räjähtää, jos se on virheellisesti asennettu. Vaihda paristo ainoastaan laitevalmistajan suosittelemaan tyyppiin. Hävitä käytetty paristo valmistajan ohjeiden mukaisesti.

## 9.7 System-level Environmental Limits

The following table defines the system level operating and non-operating environmental limits (office or computer room environment).

**Table 134. System Office Environment Summary**

Parameter	Limits
Operating temperature	5°C to 40°C
Non-operating temperature	-40°C to 70°C
Non-operating humidity	35°C @ 90% RH
Acoustic noise (EPSD idle/active)*	Workstation: 4.8/5.5 BA; Pedstal: 5.5/6.0 BA; Intel Limit: 7.0 BA
Shock, operating	2g, 11 ms 1/2 Sine, 20g, 2ms, 1/2 Sine
Shock, unpackaged	25G Trapezoidal Shock
Shock, packaged	24" Free Fall, >40, <80lbs; 30" Free Fall, >20, <40lbs
Vibration, unpackaged	5Hz to 500Hz, 2.2 grms random profile
Vibration, packaged	5Hz to 500Hz, 1.09 grms random profile
ESD*	2kV to 12 kV Air Discharge, 2kV to 8kV Contact Discharge
System Cooling Requirement in BTU/hr	

**\*IMPORTANT NOTE:** With the BIOS set to 'CLTT' memory throttling mode and '301m-900m' altitude, the Intel® Server Chassis SC5650WS pass the Intel limit (Tower PC with ≥1000W Power Supply capacity) , but do not meet the EPSD workstation target. The chassis with Intel® Server Board S5500BC requires the use of shielded LAN cable to comply with Immunity regulatory requirements. Use of non shield cables may result in the product having insufficient immunity electromagnetic effects, which may cause improper operation of the product.

## 9.8 Serviceability and Availability

This system is designed to be serviced by qualified technical personnel only.

The desired Mean Time To Repair (MTTR) of the system is 30 minutes including diagnosis of the system problem. To meet this goal, the system enclosure and hardware have been designed to minimize the MTTR.

Following are the maximum times that a trained field service technician should take to perform the listed system maintenance procedures, after diagnosis of the system.

**Table 135. Mean Time To Repair Estimate**

Activity	Time Estimate
Remove cover	< 1 minute
Remove and replace hard disk drive	1 minute
Remove and replace 5.25-inch peripheral device	<1 minute
Remove and replace fixed power supply module	<7 minutes
Remove and replace hot-swap power supply module	< 1 minute
Remove and replace drive cage fan	<1 minute
Remove and replace system fan	<2 minute
Remove and replace backplane board	<5 minutes
Remove and replace control panel board	<4 minutes
Remove and replace server board	<15 minutes

## 9.9 Calculated MTBF

The calculated MTBF (Mean Time Between Failures) for the Intel® Server Chassis SC5650, as configured from the factory, is presented in the following tables.

**Table 136. Intel® Server Chassis SC5650 Component MTBF**

Subassembly (Server in 35oC ambient air)	Server Model	
	SC5650DP	
	MTBF (hours)	FIT (flrs/10 <sup>9</sup> hrs)
S5520HC Baseboard	124,000	8,065
Power Supply	258,000	3,876
Nidec System FAN 34FN000337	70,000	14,286
Front Panel	7,000,000	143
Intrusion switch	25,000,000	40
Totals without motherboard =		18,345
Totals with motherboard =	37,900	26,409

Subassembly (Server in 35oC ambient air)	Server Model	
	SC5650BRP	
	MTBF (hours)	FIT (flrs/10 <sup>9</sup> hrs)
S5520HC Baseboard	124,000	8,065
Power Supply	356,000	2,809
Power Distribution Board	919,000	1,088
Nidec System FAN 34FN000337	100,000	10,000

Subassembly (Server in 35oC ambient air)	Server Model	
	SC5650BRP	
	MTBF (hours)	FIT (flrs/10 <sup>9</sup> hrs)
Front Panel	7,000,000	143
Intrusion switch	25,000,000	40
Totals without motherboard =		14,040
Totals with motherboard =	45300	22,105

Subassembly (Server in 35oC ambient air)	Server Model	
	SC5650WS	
	MTBF (hours)	FIT (flrs/10 <sup>9</sup> hrs)
S5520HC Baseboard	114,000	8,772
Power Supply	154,000	6,494
Nidec System FAN 34FN000337	100,000	10,000
Front Panel	7,000,000	143
Intrusion switch	25,000,000	40
Totals without motherboard =		16,636
Totals with motherboard =	39400	25,408

## ***Appendix A: Integration and Usage Tips***

This appendix provides a list of useful information that is unique to the Intel® Server Chassis SC5650 and should be kept in mind while integrating and configuring your server.

To maintain system thermals, fixed hard drive bays must be populated in the slots in this order: 1, 3, 5, 2, 4, 6.

To maintain system thermals, hot-swap hard drive bays must be populated with either a hard drive or a drive blank.

System fans are not hot swappable.

If required, the CPU air duct(s) must be used to maintain system thermals. A CPU air duct is not required on the Intel® Server Board S5500BC.

The chassis with Intel® Server Board S5500BC requires the use of shielded LAN cable to comply with Immunity regulatory requirements. Use of non shield cables may result in the product having insufficient immunity electromagnetic effects, which may cause improper operation of the product.

Make sure the latest system software is loaded on the server. This includes system BIOS, FRU/SDR, BMC firmware, and hot-swap controller firmware. The latest system software can be downloaded from <http://support.intel.com/support/motherboards/server>.



## Glossary

Word / Acronym	Definition
ACA	Australian Communication Authority
ANSI	American National Standards Institute
ATX	Advanced Technology Extended
Auto-Ranging	Power supply that automatically senses and adjust itself to the proper input voltage range (110 VAC or 220 VAC). No manual switches or manual adjustments are needed.
BMC	Baseboard Management Controller
CFM	Cubic Feet per Minute (airflow)
CMOS	Complementary Metal Oxide Silicon
Dropout	A condition that allows the line voltage input to the power supply to drop to below the minimum operating voltage.
EEB	Entry E-Bay
EMP	Emergency Management Port
FP	Front Panel
FRB	Fault Resilient Booting
FRU	Field Replaceable Unit
HSBP	Hot Swap Backplane
Latch Off	A power supply, after detecting a fault condition, shuts itself off. Even if the fault condition disappears the supply does not restart unless manual or electronic intervention occurs. Manual intervention commonly includes briefly removing and then reconnecting the supply, or it could be done through a switch. Electronic intervention could be done by electronic signals in the Server System.
LCD	Liquid Crystal Display
LCP	Local Control Panel
LPC	Low-Pin Count
Monotonically	A waveform changes from one level to another in a steady fashion, without intermediate retrenchment or oscillation.
MTBF	Mean Time Between Failure
MTTR	Mean Time to Repair
Noise	The periodic or random signals over frequency band of 10 Hz to 20 MHz.
OTP	Over Temperature Protection
Over-current	A condition in which a supply attempts to provide more output current than the amount for which it is rated. This commonly occurs if there is a 'short circuit' condition in the load attached to the supply.
OVP	Over Voltage Protection
PDB	Power Distribution Board
PFC	Power Factor Correction
PSU	Power Supply Unit
PWOK	A typical logic level output signal provided by the supply that signals the Server System that all DC output voltages are within their specified range
RI	Ring Indicate
Ripple	The periodic or random signals over frequency band of 10 Hz to 20 MHz.
Rise Time	Rise time is defined as the time it takes any output voltage to rise from 10% to 95% of its nominal voltage.
Sag	The condition where the AC line voltage drops below the nominal voltage conditions
SCA	Single Connector Attachment

Word / Acronym	Definition
SDR	Sensor Data Record
SE	Single-Ended
SSI	Server Standards Infrastructure
Surge	The condition where the AC line voltage rises above nominal voltage.
THD	Total Harmonic Distortion
UART	Universal Asynchronous Receiver Transmitter
USB	Universal Serial Bus
VCCI	Voluntary Control Council for Interference
VSB or Stand By	An output voltage that is present whenever AC power is applied to the AC inputs of the supply.