

# AVR180: External Brown-Out Protection

## Features

- Low-Voltage Detector
- Prevent Register and EEPROM Corruption
- Two Discrete Solutions
- Integrated IC Solution
- Extreme Low-Cost Solution
- Extreme Low-Power Solution
- Formulas for Component Value Calculations
- Complete with Example Schematics

## Introduction

This application note shows in detail how to prevent system malfunction during periods of insufficient power supply voltage. It describes techniques to prevent the CPU from executing code during periods of low power by use of external low voltage detectors. These events are often referred to as “Brown-Outs”, where power supply voltage drops to an insufficient level, or “Black-Outs” where power supply voltage is completely removed for a period of time.

Two discrete solutions are discussed in detail, allowing the user to calibrate the system requirements. A complete guide to integrated circuit (IC) solutions is also included. By the use of these techniques, the following can be prevented in the situations described above:

- CPU Register corruption
- I/O Register corruption
- I/O-pin random toggling
- SRAM corruption
- EEPROM corruption
- External Non-Volatile Memory corruption

Note that AVR<sup>®</sup> internal Flash Program Memory contents are never affected by insufficient power supply voltage.

## Theory of Operation

For the CPU to successfully decode and execute instructions, the supplied voltage must always stay above the minimum voltage level set by the chosen operating frequency. When supplied voltage drops below this level, the CPU may start to execute some instructions incorrectly. The result is unexpected activity on the internal data and control lines. This activity may cause CPU Registers, I/O Registers and data memories to get corrupted.

To avoid these problems, the CPU should be prevented from executing code during periods of insufficient supply voltage. This is best ensured by the use of an external Power Supply Low Voltage Detector. Below a fixed threshold voltage  $V_T$ , the detector circuit forces the RESET pin low (active). Forcing RESET low immediately stops the CPU from executing code. While the supplied voltage is below the required threshold voltage  $V_T$ , the MCU is halted, making sure the system stays in a known state. When the supplied voltage rises above this pre-defined voltage, the RESET pin is again released, and the MCU starts to execute code beginning at the reset vector (0x0000).

## Threshold Voltage

It is recommended to set the threshold voltage 5-15% below typical  $V_{CC}$ , to allow for small fluctuations in supplied voltage. The threshold voltage should always be selected to ensure that the detector will keep the device properly reset when supply voltage drops below the critical voltage required by the CPU. Care should be taken to ensure sufficiently high detector threshold voltage even in worst case situations.



## 8-Bit Microcontroller

## Application Note



## Prevents CPU Register Corruption

When the detector keeps the MCU in reset, all CPU activity is halted. When released from reset, the CPU registers will all be in their default state. For the duration of the reset, the General Purpose Register File contents will be preserved.

Without a detector, random CPU activity such as described in the introduction may cause the CPU registers to get corrupted. Also see “Volatile Memory” below.

Note: The General Purpose Register File contents are not guaranteed to be preserved during reset in the AT90S1200, the AT90S8515 and the AT90S4414.

## Prevents I/O Register Corruption

When using a detector to keep the MCU in reset, all I/O registers will be kept in their default state for the duration of the reset. Consequently, all on-chip peripherals will stay in their reset state.

Without a detector, random CPU activity such as described in the introduction may write an unknown value to any I/O Register. This may cause unexpected behavior of the on-chip peripherals.

## Prevents I/O Pin Random Toggling

A detector will keep the MCU in reset, and all I/O pins will be kept in their default state for the duration of the reset.

Without a detector, random CPU activity such as described in the introduction may write a random value to the I/O Registers. This may cause random toggling of the I/O pins.

## Prevents SRAM Corruption

By the use of a detector to keep the MCU in reset, there will be no accesses to the internal SRAM. The memory contents will keep their present contents for the duration of the reset.

Without a detector, random CPU activity such as described in the introduction may write an unknown value to any SRAM location. Also see “Volatile Memory” below.

Note: The guaranteed preservation of data in internal SRAM does not apply to the AT90S8515 and 4414. In this device, the SRAM data is not guaranteed to be preserved during reset.

## Prevents Non-Volatile Memory Corruption

Non-Volatile memories like EPROM, EEPROM and Flash are designed to keep their contents even when power is completely removed from the system. By the use of a detector to keep the MCU in reset, all activity on the control lines cease. The memory contents are such prevented from unintentional writes from the CPU for the duration of the reset.

Without a detector, random CPU activity such as described in the introduction may initialize an unintended write to the

non-volatile memory. This may cause random corruption of the memory contents.

- Note:
1. As the AVR CPU is not capable of writing to its own program memory, the internal Flash Program Memory contents are never affected by a power failure situation.
  2. For any write to non-volatile memory, a minimum voltage is required to successfully write the new values into the memory. If supplied voltage at any time during the write cycle drops below the minimum voltage, the write will fail, corrupting the location written to.
  3. In some AVR devices, when the reset activates during a write to the internal EEPROM, the EEPROM Address Register will be set to zero (0x000). The result may be seen as corruption of both the location being written, and of location zero (0x000).

## Flash Program Memory

The Internal Flash Program Memory contents are never affected by a power failure situation. The AVR CPU is incapable of writing to its own program memory.

## Volatile Memory

Even when external low voltage detectors halts the CPU, volatile memory (like Registers and RAM) will eventually lose their contents if the supply voltage drops below the minimum voltage required for each memory cell to preserve its current value. When the CPU is halted, the minimum voltage where the AVR internal RAM is guaranteed to preserve the contents is typically 2.0 volts. Factory tests on actual silicon have shown that AVR devices may preserve the RAM contents even down to 0.5 - 1.0 volts.

## Implementation

A variety of integrated circuit (IC) solutions are available from a range of manufacturers. These offer a high accuracy solution at a low price, typically guaranteeing the threshold voltage to be within  $\pm 1\%$ . Although the elementary three pin fixed voltage detector is available, there is also a whole range of devices offering additional features like reset pulse stretching, power-on reset time-out, watchdogs, power regulation, dual supply switching for UPS operation and more. Included in this application note is a guide to the world of integrated circuit solutions. As an alternative, this application note also presents two discrete Low-Power Supply Voltage RESET detectors.

- Alternative 1: Minimum Power Consumption. Well-suited for battery-powered applications where power consumption is the most critical parameter.
- Alternative 2: Minimum Cost. This is a minimum component cost solution for applications where cost is a key parameter and power consumption is not critical.

- Alternative 3: High accuracy. High-quality semiconductor ICs are used to build an accurate brown-out detector with low-power consumption.

## Design Hint: Supply Voltage Filtering

Use low impedance capacitors (low ESR and ESL) on the  $V_{CC}$  and multi-layer PCB with power planes to improve transient rejection from the power supply.

## Alternative 1: Low-Power Consumption

### Characteristics

- Very Low-Power Consumption, (Typ  $0.5\mu\text{A}@3\text{V}$ ,  $1\mu\text{A}@5\text{V}$ )
- Low-Cost
- Large Hysteresis, Typ. 0.3 Volts
- Fast Output Transitions
- Accuracy  $\pm 5\text{-}10\%$
- High Component Count
- Long Response Time on  $V_{CC}$

Figure 1. Low-Power Consumption Brown-Out Detector

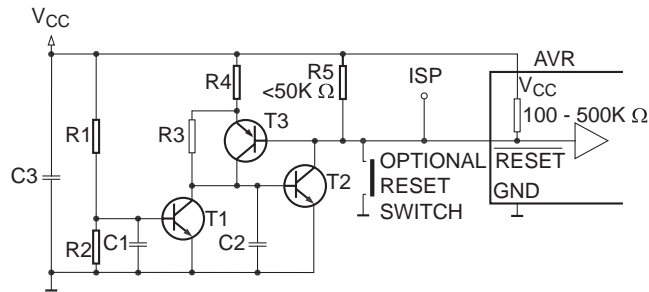
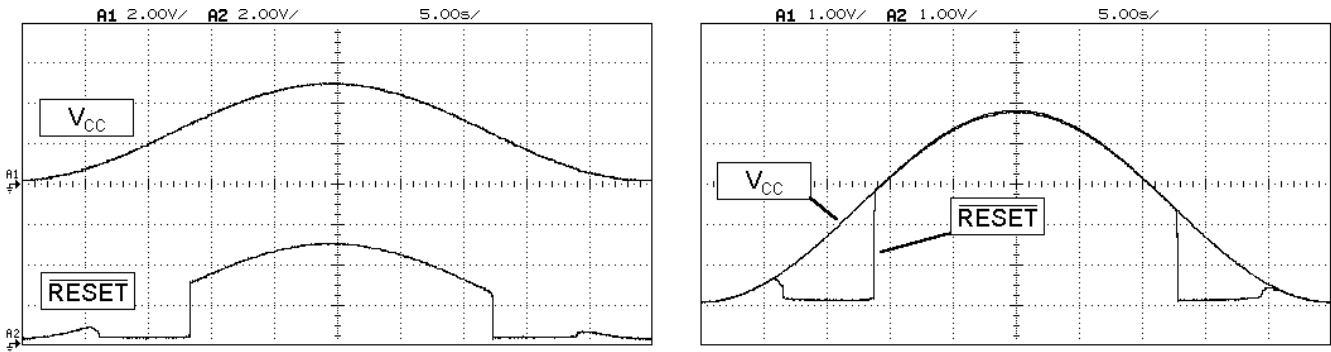

Figure 2. These Oscilloscope Plots Show How the Voltage on RESET Varies with  $V_{CC}$



### Introduction

The circuit in Figure 1 benefits from low-power consumption, which makes it suitable for battery operated applications. Standard discrete components give a low cost design.

The voltage transition on the RESET pin is very steep. Combined with the large hysteresis, the accuracy is high. On the other hand, the response time is slow, which makes it unsuitable for rapidly varying supply voltages.

### Theory of Operation

This detector has two stages, the detector and the amplifier. In the detector stage, the threshold voltage is set by

the resistors R1 and R2 in relation to the critical voltage of transistor T1. Under normal operation, this transistor is conducting, When the supply voltage drops below the threshold voltage, the transistor shuts off.

The output from this detector is lead to the input of the ultra low power amplifier stage. Under normal operation, the low voltage of the base of transistor T2 causes it to remain shut, allowing resistor R5 to pull the RESET input high. The amplifier stage also contains a hysteresis feedback loop through transistor T3, shorting resistor R3 in the amplifier when the RESET output is kept low.

## Choosing Components

### T1, T2 and T3

The production spread of current gain  $\beta$  (or  $h_{FE}$ ) in transistors T1 affects the threshold voltage  $V_T$  (typically  $\pm 0.2$  volts). Most small signal transistors can be used, but low production spread transistors are recommended.

Care should be taken if transistor T1 is changed from one type to another. The emitter-base threshold voltage of T1 affects the constant (0.4) in the equation for threshold voltage (below). As a consequence, a change of transistor could cause a change in the threshold voltage of the detector, which requires the voltage divider R1 + R2 to be recalculated.

### R1 and R2

R1 and R2 forms a voltage divider that defines the threshold voltage  $V_T$ . As the threshold voltage depends on these resistors, it is recommended to choose resistors with 1% tolerance or better. Also see “Noise Sensitivity” below.

R1 is usually chosen equal to 10 M $\Omega$  to ensure the lowest power consumption possible. R2 is then found by the equation below. The constant (0.4) in the equation may vary slightly with variations in transistor T1:

$$V_T = (R1 + R2) \cdot \left(\frac{0.4}{R2}\right), \text{ or } R2 = \frac{0.4 \cdot R1}{V_T - 0.4}$$

### R3

R3 is a non-critical pull-up resistor which has very little influence on the threshold voltage. It should be selected as large as possible to minimize power consumption. A resistance of R3 greater than 10 M $\Omega$  is not recommended, see “Noise Sensitivity” below.

### R4

Resistor R4 defines the hysteresis of the threshold voltage ( $V_T$ ). By choosing R4 to 3.3 M $\Omega$ , the resulting hysteresis will be approximately 0.3 volts. A smaller R4 will give a larger hysteresis, a larger R4 gives smaller hysteresis. A larger R4 will also result in a less sharp transition in the output slope. Large deviations from the recommended value will eventually alter the constant 0.4 in the threshold voltage equation above. As the hysteresis is only slightly changed with variation in R4 resistance, the accuracy is not critical.

### R5

Resistor R5 pulls the RESET pin high in normal operating mode. A value less than 50 k $\Omega$  is recommended to tie RESET sufficiently hard to  $V_{CC}$ . As no current passes through this resistor in normal operating mode, its value and accuracy is otherwise of little importance. When

RESET is pulled low, this resistor will start conducting a relatively large current.

### C1 and C2

Capacitors C1 and C2 short RF noise picked up in the circuitry and amplified by the transistors. Both capacitors can be omitted, but a value greater than 1nF is recommended. For maximum noise immunity, 100 nF (LF) or capacitors with lower ESR (HF) should be selected when possible. Also see “Response Time” below. The accuracy is not critical, but to ensure proper RF decoupling, the capacitors should have Z5U dielectric or better.

### C3

Capacitor C3 decouples the power lines. It can be omitted if there is RF decoupling of the power lines somewhere nearby on the circuit board, otherwise 1nF is recommended. For maximum noise immunity, 100 nF (LF) or low ESR (HF) should be selected.

## Reset Switch / In-System Programming

If a push button reset and/or ISP capabilities are required, they are simply connected in parallel as shown in Figure 1. As the switch/programmer will pull RESET low, power consumption in R5 will be relatively high for the duration of the event. Also see “Power Consumption” below.

## Response Time

Choosing large values for capacitors C1 and C2 will slow down the circuit’s response time. This is not a problem with battery driven applications where the supply voltage decreases slowly over time. Observe that the response time also applies to the time immediately following power-on. This might affect operation when a flat battery is loaded. When power can drop more rapidly, the longer response time should be taken into consideration.

## Noise Sensitivity

Choosing values of R1 and R3 greater than 10 M $\Omega$  is not recommended, as it makes the circuitry sensitive to thermal noise generated in the resistor. When noise is not critical, the values of R1 and R3 can be raised to 20 M $\Omega$ . Choosing larger values will result in the resistors not conducting sufficient current, giving in a non-functional detector. If more noise immunity is required, these resistors can be chosen smaller, at the expense of increased power consumption.

Capacitors C1, C2 and C3 are decoupling capacitors to minimize noise sensitivity to both RF and 50/60 Hz fields. They can all be omitted, but the noise immunity depend strongly on the values selected.

## Threshold Accuracy

As the threshold voltage is defined mainly by R1 and R2, inaccuracies in these resistors directly influence the threshold voltage accuracy. It is recommended to choose these with  $\pm 1\%$  tolerance.

## Power Consumption

The current consumption in normal operating mode (sufficiently high  $V_{CC}$ ) is found by:

$$I \approx \left( \frac{V_{CC}}{(R1 + R2) \parallel (R3 + R4)} \right) = V_{CC} \left( \frac{1}{R1 + R2} + \frac{1}{R3 + R4} \right)$$

When reset switch or programmer force RESET to GND, the current increases to:

$$I \approx \frac{V_{CC}}{(R1 + R2) \parallel (R3 + R4) \parallel R5 \parallel R_{RESET}}$$

When voltage drops to the level where the detector activates, transistor T1 closes, T2 opens and the current is:

$$I \approx \frac{V_{CC}}{(R1 + R2) \parallel R5 \parallel R_{RESET}}$$

As resistor R5 is usually chosen much smaller than the other resistors R1-R4, the last two expressions both simplify to:

$$I \approx \frac{V_{CC}}{R5 \parallel R_{RESET}}$$

**Table 1.** Example Values

Component	Example Values		Recommended Tolerance
	3.0V	4.5V	
T1, T2	BC548 / BC848 / 2N3904		$I_{CE} \geq 2.5 \text{ mA}$ , $V_{CE} \geq 8 \text{ V}$ , $\beta/h_{FE} \geq 100$
T3	BC558 / BC858 / 2N3906		$I_{CE} \geq 2.5 \text{ mA}$ , $V_{CE} \geq 8 \text{ V}$ , $\beta/h_{FE} \geq 100$
R1	10 M $\Omega$		$\leq 1\%$
R2	1.54 M $\Omega$	976 k $\Omega$	$\leq 1\%$
R3	10 M $\Omega$		$\leq 20\%$
R4	3.3 M $\Omega$		$\leq 20\%$
R5	47 k $\Omega$		$\leq 20\%$
C1, C2, C3	100 nF		$\leq 20\%$ , Z5U dielectric or better

## Alternative 2: Low-Cost

### Characteristics

- Low-Component Count
- Very Low-Cost
- Small Footprint
- Short Response Time
- Small Hysteresis
- Output Drops Slowly with  $V_{CC}$
- Low Accuracy ( $\pm 4\text{-}8\%$ )
- High Current Consumption
- Sensitive to Component Variations

Figure 3a. Low-Cost Brown-Out Detector

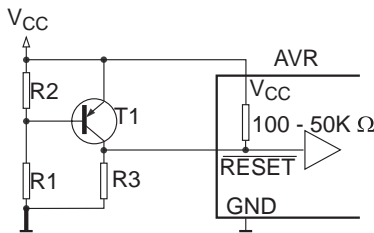

Figure 3b. Low-Cost Brown-Out Detector with Manual Reset Button

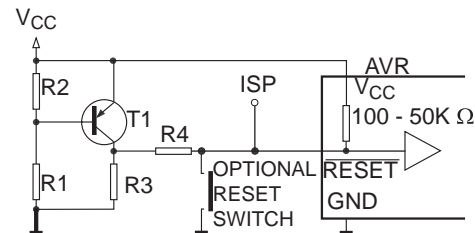
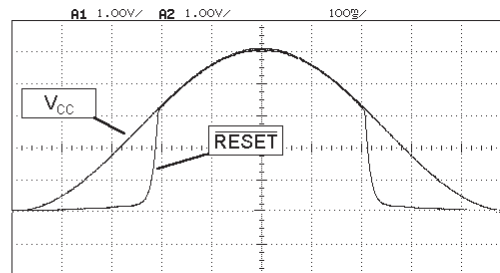
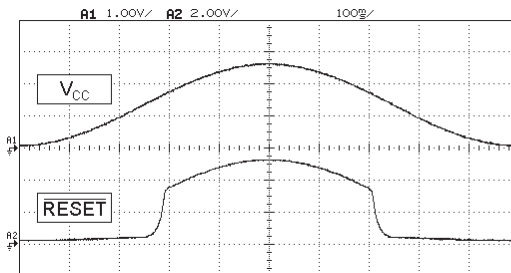

Figure 4. These Oscilloscope Plots Show how the Voltage on RESET Varies with  $V_{CC}$



### Introduction

Figure 3a is showing a circuit that features low cost and small physical size. However, its high current consumption might make it unsuited for battery operated applications. As the voltage transition on the RESET pin is fairly slow when  $V_{CC}$  drops, the circuit is sensitive to inaccuracies in component values. Due to inaccuracies in resistors R1 and R2, transistor T1 and AVR MCU RESET threshold value, the threshold value  $V_T$  should be chosen minimum 15% below nominal  $V_{CC}$ .

### Theory of Operation

During normal operation, the transistor T1 is open, keeping RESET at  $V_{CC}$ . When the supply voltage  $V_{CC}$  drops below the threshold voltage ( $V_T$ ), the transistor T1 closes. This allows resistor R3 to pull RESET low (active). The closing of the transistor T1 occurs when the voltage from emitter to base drops below a certain value, usually 0.7 volts in small signal silicon transistors.

R1 and R2 is a voltage divider that controls the emitter-base voltage. The threshold voltage,  $V_T$ , is defined by:

$$V_T \approx 0.7 \cdot \frac{R1 + R2}{R2}, \text{ or } \frac{R1}{R2} \approx \frac{V_T}{0.7} - 1$$

### Choosing Components

#### T1

Almost any small signal PNP transistor can be used. One with high gain ( $\beta/h_{FE}$ ) is recommended as it gives faster transitions in the output voltage with variations in  $V_{CC}$  around the threshold voltage. Faster transitions make the circuit more immune to component variation, reducing the need to calibrate the detector. Also see "Threshold Accuracy" on page 4.

Calibration is also required if the threshold voltage for the transistor varies. This voltage is the constant 0.7 in the equation above. The voltage is stable for the same type of

transistor, but take care when selecting a transistor. A change in this parameter will seriously affect the threshold voltage of the detector.

### R1 and R2

As the formula states, the threshold voltage  $V_T$  is dependent upon R1 and R2. Resistor R1 should be about 200 k $\Omega$  or lower. This ensures that the current out of the transistor T1's base will not influence the voltage divider R1-R2. (This is for an amplification ( $\beta/h_{FE}$ ) value of at least 100.)

### R3

The AVR's RESET pin has an internal pull-up resistor with a nominal value of 100-500 k $\Omega$ . When transistor T1 is off, the internal pull-up and R3 form a voltage divider. The resulting RESET voltage has to be sufficiently low to assure that the MCU RESET line is held active. The recommended value for resistor R3 is 50 k $\Omega$  or lower, which ensures that the voltage at RESET is always less than  $1/3 \cdot V_{CC}$ .

### Reset Switch/In-System Programming

If push button reset and/or ISP capabilities are required, a series resistor R4 must be connected as shown in Figure 3b. This resistor allows the reset switch/programmer to override the transistor T1 and pull the RESET pin low. To ensure proper low voltage detector operation, the series resistance in R3 + R4 should not exceed the recommended 50 k $\Omega$ .

### Threshold Accuracy

As the threshold voltage is defined mainly by R1 and R2, inaccuracies in these resistors directly influence the threshold voltage. It is recommended to use resistors with  $\pm 1\%$  tolerance.

**Table 2.** Example Values

Component	Example Values		Recommended Tolerance
	$V_T = 3.0V$	$V_T = 4.5V$	
T1	BC558 / BC858 / 2N3906		$I_{CE} \geq 2.5 \text{ mA}$ , $V_{CE} \geq 8 \text{ V}$ , $\beta/h_{FE} \geq 100$
R1	180 k $\Omega$		$\leq 1\%$
R2	56 k $\Omega$	33 k $\Omega$	$\leq 1\%$
R3	$\leq 47 \text{ k}\Omega$		$\leq 20\%$
R4	$\leq 4.7 \text{ k}$		$\leq 20\%$

Due to the slow transitions on the output of the detector, variations in RESET threshold in the AVR MCU will lead to inaccuracies in threshold voltage. This inaccuracy is typically  $\pm 0.15$  volts, which equals  $\pm 3\%$  in a 5V system. ( $\pm 5\%$  at 3.3V). This inaccuracy is lowered by choosing a transistor T1 with higher gain ( $\beta/h_{FE}$ ) which increases the transition speed.

### Power Consumption

The current through the detector in normal operating mode (sufficiently high  $V_{CC}$ ) is found by:

$$I \approx \frac{V_{CC}}{(R1 + R2) \parallel R3} = V_{CC} \left( \frac{1}{R1 + R2} + \frac{1}{R3} \right)$$

When switch or programmer force RESET to GND, the current increases to:

$$I \approx \frac{V_{CC}}{(R1 + R2) \parallel R3 \parallel R4 \parallel R_{RESET}}$$

When voltage drops to the level where the transistor T1 closes, the current drops to:

$$I \approx \frac{V_{CC}}{(R1 + R2) \parallel (R3 + R4 + R_{RESET})}$$

## Alternative 3: Integrated Circuit Solutions

### Characteristics

- Easy to Mount
- Very Accurate Threshold Voltage
- Low Power Consumption
- Small Footprint
- Low Component Count
- Wide Variety in Additional Functionality

### Introduction

A selection of integrated circuits is available from various semiconductor suppliers. They vary from simple 3-pin fixed voltage detectors to advanced circuitry containing watchdog timers and power on reset (POR) time-outs. Because all AVR MCUs have built-in watchdog and POR circuitry, these functions do not require handling by the external IC. The threshold accuracy is better than  $\pm 1\%$  for most circuits. Current consumption is in the  $\mu\text{A}$  range. Make sure to choose a device with an active low output. A wide variety of package types are available, ranging from miniature three-pin SOT-23 to large packages with high pin count.

**Figure 5a.** Detector with Push-Pull Output

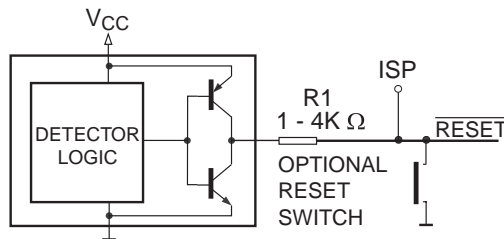

**Figure 5b.** Detector with Open-Drain Output

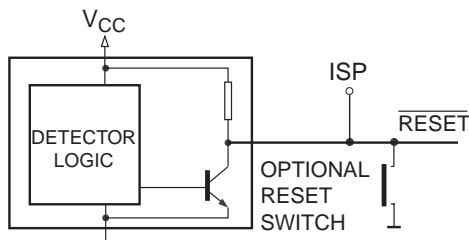

**Figure 5c.** Alternative Location of Manual Reset Switch

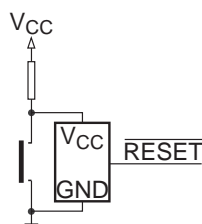

### Output Driver

The IC reset output can be push-pull or open drain (open collector), either CMOS or TTL output levels. Open drain

solutions allow easy connection of a manual reset button and/or in-system programmers. This feature can also be implemented with push-pull outputs, with the addition of a resistor in series with the output. The ISP and/or manual button is connected between the resistor and the AVR RESET input (see Figure 5a and Figure 5b).

**Figure 6.** Reset Pulse Stretching

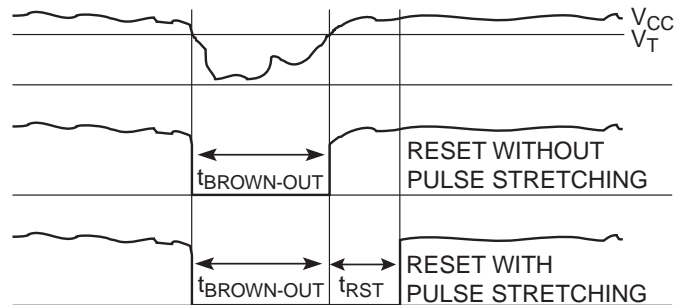

### Reset Pulse Stretching

An additional feature in some of these circuits is stretching of the reset pulse. The reset is held active for a defined amount of time after the condition (power-on reset, brown-out reset etc.) that caused the reset has returned to normal (see Figure 6). Some of these devices also provide this feature for the manual reset. The device senses the output level, detecting the closing and opening of a reset button. When the button is released, the device keeps the reset line active for an additional amount of time. **WARNING!** This feature will interfere with the operation of an in-system programmer, which toggles the RESET line actively.

### Power Regulator

Several integrated power regulators includes the low-voltage detector, combining both functionalities in one device. This reduces part count, and often adds the functionality at no extra cost.

### Battery Backup Solutions

Some systems contain a battery to supply power when the main power drops. The power regulator in such systems often provides a status signal to the MCU telling which source currently supplies power to the circuit. Connecting this signal to RESET will shut the AVR down when battery power is used, preserving RAM contents but halting execution. Alternatively, connecting this signal to an input pin, the AVR can detect the event and execute a safe power down sequence, switching off power hungry peripheral equipment (motor, display etc.) before entering power-down mode. (The power consumption in RESET is the same as in normal active running mode, whereas the consumption in power down mode is in the  $\mu\text{A}$  range.) When main power supply voltage returns to an acceptable level, the AVR



should detect the event, wake up and resume execution where it left off.

**Figure 7.** Adding Hysteresis to Threshold Voltage

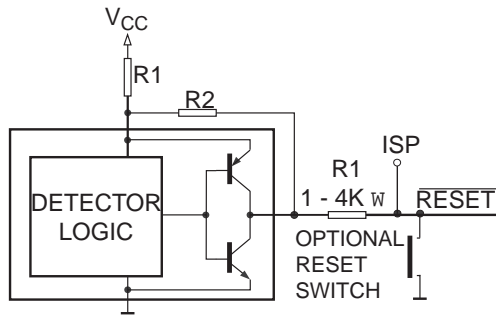

### Hysteresis

Hysteresis in the low-voltage detector might be implemented in the integrated circuit, or can be added with external circuitry (Figure 7). This prevents the detector from oscillating when used in battery applications.

**Figure 8.** Integrated Reset Circuit with Preset Threshold Voltage

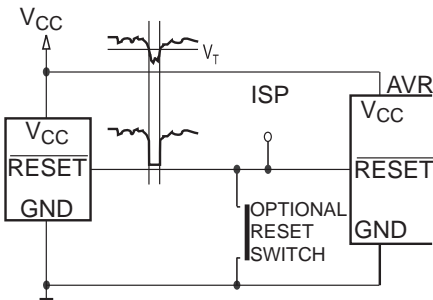
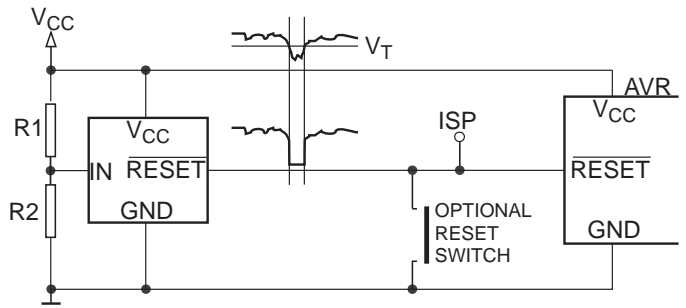

**Table 3.** Example Devices

Device	Features	ISP Support	Cost Level <sup>(4)</sup>
MAX809 <sup>(1)</sup>	Fixed Threshold Voltage, Fixed Pulse Stretching	Yes	A
MAX811 <sup>(1)</sup>	Fixed Threshold Voltage, Fixed Pulse Stretching, Low Power, Manual Reset Input	Yes	A
MAX821 <sup>(1)</sup>	Fixed Threshold Voltage, Adjustable Pulse Stretching, Low Power	Yes	
DS1811 <sup>(2)</sup>	Fixed Threshold Voltage, Fixed Pulse Stretching	Yes	
DS1813/18 <sup>(2)</sup>	Fixed Threshold Voltage, Fixed Pulse Stretching, Feedback Monitor	No	
V6301 <sup>(3)</sup>	Fixed Threshold Voltage, Fixed Pulse Stretching, Low Power, Low Cost	Yes	C
V6340 <sup>(3)</sup>	Fixed Threshold Voltage, No Pulse Stretching, Low Cost	Yes	C

- Notes:
- Offered by Maxim Integrated Product, Inc.
  - Offered by Dallas Semiconductors
  - Offered by EM Microelectronic-Marin SA
  - A = expensive  
B = moderate  
C = inexpensive

**Figure 9.** Integrated Reset Circuit with Adjustable Threshold Voltage



### Fixed/Adjustable Threshold Voltage

Some circuits offer the threshold voltage  $V_T$  to be tuned by external components, while others have a preset threshold voltage reference. The use of a fixed threshold voltage IC is shown in Figure 8.

The typical connection for externally tuned threshold voltage is shown in Figure 9. This device offers an internal voltage reference and a comparator. If the voltage at the input pin is higher than the reference voltage, the output will be activated. The threshold voltage is easily defined by a voltage divider, R1 and R2.



